



Single-Board Image Processor Includes Embedded CPU

mvPower combines Datacube's proven pipeline processing technology with the exceptional performance of Motorola's 100 MHz PowerPC® 603e chip in a low-cost, high-performance, single-slot solution for VMEbus-based platforms. This single-board approach eliminates the need to buy and configure separate CPU and image processing boards to build a system capable of handling your machine vision application needs.

mvPower is supported by the MaxVision Toolkit, Datacube's extensive suite of software tools designed to simplify development of machine vision applications. Either serial or VME communication protocols can be used to control the *mvPower*. The result is an easy-to-use and cost-effective stand-alone image processing engine that can be optimized for specific applications.

Motorola's PowerPCs are significantly faster than the 680x0 processors used on the MVME167 and MVME147 CPU boards, also from Motorola. This superscalar microprocessor architecture is capable of issuing and retiring as many as three instructions per clock cycle using five independent execution units. The 603e can execute a single-precision, floating-point multiply and add operation in every clock cycle. Embedding the PowerPC 603e enables local control of image processing hardware, which reduces traffic on the VMEbus.

mvPower runs VxWorks, a very efficient real-time operating system that supports multi-tasking. VxWorks is highly deterministic and has fast context switching times.

Image Processing ASICs

The *mvPower* board is equipped with four custom image processing ASICs: an Arithmetic Unit (AU) and three Virtual Surface Image Memory (VSIM) modules, developed by Datacube.

The AU is a built-in arithmetic processor and crosspoint switch that has been fine-tuned specifically for image processing. It includes four 11-bit multipliers feeding an adder tree, seven 10-bit ALUs, two run-length encoders, two 20-bit statistical processors, and

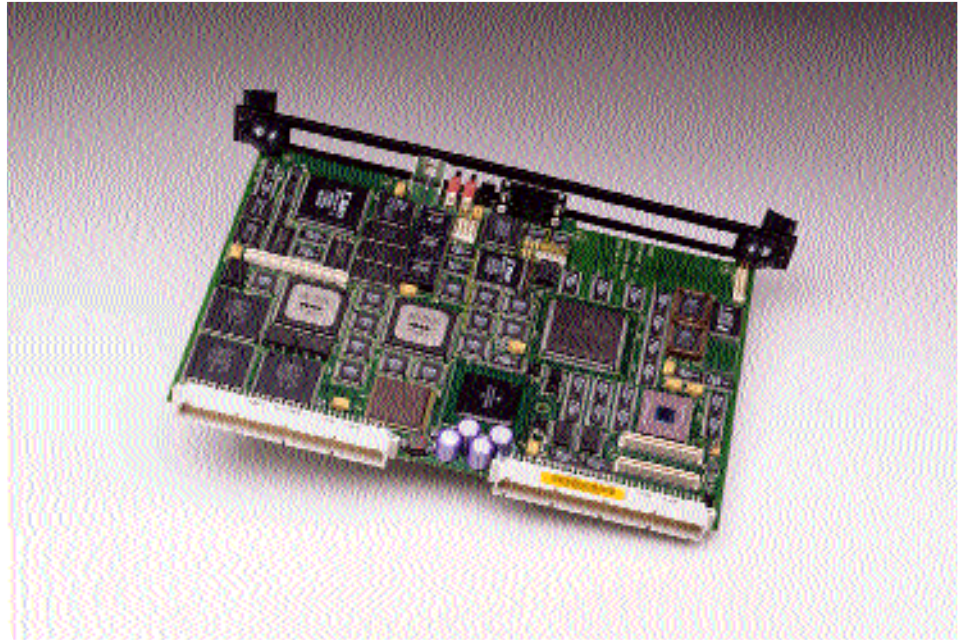

two row and column address generators.

mvPower includes a total of 6 MB of VSIM memory which, in addition to storing images in memory, is capable of certain image processing functions. Each of Datacube's VSIM modules has a crosspoint switch, statistical processor, LUT, ALU, and feature extractor — all capable of processing pixels at 40 MB/second.

MaxACQ Acquisition Module

MaxACQ, Datacube's new line of acquisition modules, provides high throughput and simplifies integration for most analog and digital sensors including area, line-scan, and TDI types in a range of resolutions.

The basic acquisition module on *mvPower* is the QA MaxACQ module. The QA module has two 4:1 camera multiplexers (MUX) and supports simultaneous acquisition of 8-bit data from two cameras.

Software

The MaxVision Toolkit simplifies applications development with a group of fast, highly accurate, and easy-to-use machine vision tools. The Toolkit combines software for image acquisition, preprocessing, object finding (correlation or blob analysis), metrology, and camera calibration in a package specifically designed to minimize programming time for machine vision applications.

A New Standard

Compared to existing technology, *mvPower* provides significantly enhanced power and precision, at a comparable or even lower cost. *mvPower* makes possible a wide range of applications that were not able to be automated until now. *mvPower* combines the proven benefits of Datacube's pipeline image processing with the newly available technology of Motorola's PowerPC to set a new standard for machine vision image processing engines.

- Low-cost, single-board design that delivers high performance and high precision
- Software suite of exceptionally accurate, easy-to-use machine vision tools
- Complete image processing engine for machine vision in a single VME slot
- Ideal for SMD placement, wire bonding, die bonding, wafer steppers, robot guidance, label inspection, etc.
- A stand-alone image processing engine that simplifies integration and improves performance



Specifications

Physical Description

- Requires one 6U VME slot
- Power: 30 watts (approx.)

mvPower Board Features

- 100 MHz PowerPC 603e microprocessor
- Superscalar
- 32 KB cache
- Motorola specifications:
 - SPECint 92: 120
 - SPECfp 92: 105
- 8 or 16 MB of DRAM
- MaxACQ: High-performance acquisition module
- Three frame buffers: two of 1 MB each and a third of either 1 MB or 4 MB
- High Speed Image Access (HSIA) for the PowerPC
- Four image processing ASICs
- 16x16 LUTs for general 8-bit dyadic operations
- Binary and grey-scale morphology
- 0, 2, 4, or 8 MB flash storage
- Monochrome RS-170 display with two bitplanes of graphics overlay
- PMC connector for future expandability

Hardware

MaxACQ Module (QA)

- Analog camera acquisition
- Analog circuitry isolated on daughter card
- Completely programmable
- Two simultaneous acquires of 8-bit data
- Two 4:1 camera multiplexers
- Programmable gain, offset, DC clamp
- Trigger inputs and strobe light outputs with timers
- 300 K FIFO interface

NOTE: Other MaxACQ modules are available. Call Datacube for more information.

Arithmetic Unit (AU)

- Four 11-bit multipliers and adder tree
- Seven 10-bit ALUs reconfigurable as three 20-bit ALUs
- Two run-length encoders
- Two 20-bit statistical processors
- Two row and column address generators
- Crosspoint switch: ten 8-bit data paths

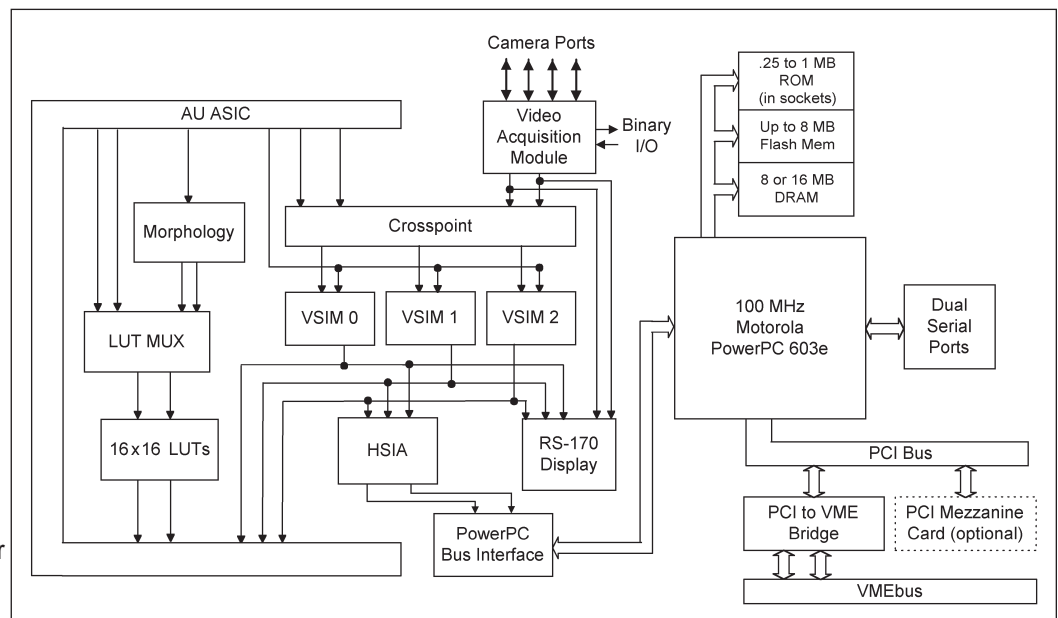

Simplified mvPower Block Diagram

Virtual Surface Image Memory (VSIM)

- 40 MHz memory/processor
- Triple-ported image memory
- 4x4 crosspoint switch
- Statistical processor: sum, sum², min, max, and count of pixels or of row and column addresses
- 9-bit ALU and 8-bit LUT
- Feature extractor
- Zooming of image data

Software

VxWorks Operating System

- Real-time, deterministic OS proven in industrial applications

MaxVision Toolkit

- Finder Tools:
 - Normalized grey-scale correlation
 - Connectivity: comprehensive blob statistics
- Metrology Tools:
 - Line fitter
 - Arc fitter
 - Edge locator
- Inspection:
 - Golden template
 - Pixel counting
 - Histogramming
- Image Processing:
 - Sobel edge filters
 - Cross gradient edge filters
 - Threshold operations
 - Morphology: binary or grey-scale
 - Image arithmetic: add, subtr., max, min
 - Image copy
 - Projection in X and Y
 - Convolutions

Input/Output:

- Image Acquisition: full frame or field, interlaced or non-interlaced
- Shuttered cameras and light controls
- Double buffering overlaps processing with acquisition
- Live video, grey-scale, or binary display of captured images
- Binary I/O: multiple inputs and outputs (input can indicate part presence to trigger acquisition)

Calibration

- Accurate 2-D procedure corrects for perspective distortion
- All functions and tools automatically make use of the calibration data
- Local coordinate transformations
- Miscellaneous Features
 - Deep pixels: exceptional accuracy by using pixel depths greater than 8 bits
 - Region-of-interest (ROI) processing
 - Automatic tool positioning
 - Library of 2-D geometry routines

Additional Information

For more information about the products mentioned in this document, please refer to the following Datacube literature:

MaxVision Toolkit Data Sheet MaxACQ Data Sheets (various)

Datacube and mvPower are registered trademarks of Datacube, Inc. All other trademarks are the property of their respective holders. **IMPORTANT NOTICE:** Datacube is not authorized by any state or federal agency as an authorized supplier of product for medical, life support, or life sustaining devices or system. All specifications subject to change without notice. (11/98) DS0085-4.1

