

KEITHLEY INSTRUMENTS

Model 236 Source Measure Unit and Model 237 High Voltage Source Measure Unit Service Manual



Contains Servicing Information for the Model 236/237

Publication Date: October 1991
Document Number: 236-902-01 Rev. D

WARRANTY

Keithley Instruments, Inc. warrants this product to be free from defects in material and workmanship for a period of 1 year from date of shipment.

Keithley Instruments, Inc. warrants the following items for 90 days from the date of shipment: probes, cables, rechargeable batteries, diskettes, and documentation.

During the warranty period, we will, at our option, either repair or replace any product that proves to be defective.

To exercise this warranty, write or call your local Keithley representative, or contact Keithley headquarters in Cleveland, Ohio. You will be given prompt assistance and return instructions. Send the product, transportation prepaid, to the indicated service facility. Repairs will be made and the product returned, transportation prepaid. Repaired or replaced products are warranted for the balance of the original warranty period, or at least 90 days.

LIMITATION OF WARRANTY

This warranty does not apply to defects resulting from product modification without Keithley's express written consent, or misuse of any product or part. This warranty also does not apply to fuses, software, non-rechargeable batteries, damage from battery leakage, or problems arising from normal wear or failure to follow instructions.

THIS WARRANTY IS IN LIEU OF ALL OTHER WARRANTIES, EXPRESSED OR IMPLIED, INCLUDING ANY IMPLIED WARRANTY OF MERCHANTABILITY OR FITNESS FOR A PARTICULAR USE. THE REMEDIES PROVIDED HEREIN ARE BUYER'S SOLE AND EXCLUSIVE REMEDIES.

NEITHER KEITHLEY INSTRUMENTS, INC. NOR ANY OF ITS EMPLOYEES SHALL BE LIABLE FOR ANY DIRECT, INDIRECT, SPECIAL, INCIDENTAL OR CONSEQUENTIAL DAMAGES ARISING OUT OF THE USE OF ITS INSTRUMENTS AND SOFTWARE EVEN IF KEITHLEY INSTRUMENTS, INC., HAS BEEN ADVISED IN ADVANCE OF THE POSSIBILITY OF SUCH DAMAGES. SUCH EXCLUDED DAMAGES SHALL INCLUDE, BUT ARE NOT LIMITED TO: COSTS OF REMOVAL AND INSTALLATION, LOSSES SUSTAINED AS THE RESULT OF INJURY TO ANY PERSON, OR DAMAGE TO PROPERTY.

KEITHLEY

Instruments Division, Keithley Instruments, Inc. • 28775 Aurora Road • Cleveland, Ohio 44139 • (216) 248-0400 • Fax: (216) 248-6168

AUSTRIA:

Keithley Instruments GesmbH • Rosenhugelstrasse 12 • A-1120 Wien • 0222-804-6548 • Fax: 0222-804-3597

FRANCE:

Keithley Instruments SARL • 3 Allee des Garays • B.P. 60 • 91121 Palaiseau Cedex • 01-60-11-51-55 • Fax: 01-60-11-77-26

GERMANY:

Keithley Instruments GmbH • Landsberger Str. 65 • D-8034 Germering • 089-849307-0 • Fax: 089-84930759

GREAT BRITAIN:

Keithley Instruments, Ltd. • The Minster • 58 Portman Road • Reading, Berkshire RG3 1EA • 0734-575666 • Fax: 0734-596469

ITALY:

Keithley Instruments SRL • Viale S. Gimignano 38 • 20146 Milano • 02-48303008 • Fax: 02-48302274

JAPAN:

Keithley Instruments Far East KK • Sumiyoshi 24 Bldg., Room 201 • 2-24-2 Sumiyoshi-Cho • Naka-Ku, Yohohama 231 • 81-45-201-2246 • Fax: 81-45-201-2247

NETHERLANDS:

Keithley Instruments BV • Avelingen West 49 • 4202 MS Gorinchem • Postbus 559 • 4200 AN Gorinchem • 01830-35333 • Fax: 01830-30821

SWITZERLAND:

Keithley Instruments SA • Kriesbachstrasse 4 • 8600 Dubendorf • 01-821-9444 • Fax: 01-820-3081

TAIWAN:

Keithley Instruments Taiwan • Room 1105, 11th Floor, No. 147 • Section 2, Chien Kuo North Road • Taipei, Taiwan R.O.C. • 886-2-509-4465 • Fax: 886-2-509-4473

Service Manual
Model 236 Source Measure Unit
Model 237 High Voltage Source Measure Unit

©1990, Keithley Instruments, Inc.
All Rights Reserved
Instruments Division
Cleveland, Ohio, U. S. A.
Document Number: 236-902-01

All Keithley products are trademarks or registered trademarks of Keithley Instruments, Inc.

Other brand and product names are trademarks or registered trademarks of their respective holders.

BESCHEINIGUNG DES HERSTELLERS/IMPORTEURS

Hiermit wird bescheinigt, (daß)/das MODEL 236/237/238 SOURCE MEASURE UNIT in Übereinstimmung mit den Bestimmungen der Vfg 1046/1984 funk-entstört ist. Der Deutschen Bundespost wurde das Inverkehrbringen dieses Gerätes angezeigt und die Berechtigung zur Überprüfung der Serie auf Einhaltung der Bestimmungen eingeräumt.

Die Einhaltung der betreffenden Bestimmungen setzt voraus, daß, (dass) geschirmte Meßleitungen verwendet werden. Für die Beschaffung richtiger Meßleitungen ist der Betreiber verantwortlich.

DIESES GERAET WURDE SOWOHL EINZELN ALS AUCH IN EINER ANLAGE, DIE EINEN NORMALEN ANWENDUNGSFALL NACHBILDET, AUF DIE EINHALTUNG DER FUNK-ENTSTOERBESTIMMUNGEN GEPRUEFT. EST IS JEDOCH MOEGlich, DASS DIE FUNK-ENTSTOERBESTIMMUNGEN UNTER UNGUENSTIGEN UMSTAENDEN BEI ANDEREN GERAETEKOMBINATIONEN NICHT EINGEHALTEN WERDEN. FUER DIE EINHALTUNG DER FUNK-ENTSTOERBESTIMMUNGEN SEINER GESAMTEN ANLAGE, IN DER DIESES GERAET BETRIEBEN WIRD, IST DER BETREIBER VERANTWORTLICH.

Keithley Instruments, Incorporated

CERTIFICATE BY MANUFACTURER/IMPORTER

This is to certify that the MODEL 236/237/238 SOURCE MEASURE UNIT is shielded against radio interference in accordance with the provisions of Vfg 1046/1984. The German Postal Services have been advised that this device is being put on the market and that they have been given the right to inspect the series for compliance with the regulations.

Compliance with applicable regulations depends on the use of shielded cables. It is the user who is responsible for procuring the appropriate cables.

THIS EQUIPMENT HAS BEEN TESTED CONCERNING COMPLIANCE WITH THE RELEVANT RFI PROTECTION REQUIREMENTS BOTH INDIVIDUALLY AND ON SYSTEM LEVEL (TO SIMULATE NORMAL OPERATION CONDITIONS). HOWEVER, IT IS POSSIBLE THAT THESE RFI REQUIREMENTS ARE NOT MET UNDER CERTAIN UNFAVORABLE CONDITIONS IN OTHER INSTALLATIONS. IT IS THE USER WHO IS RESPONSIBLE FOR COMPLIANCE OF HIS PARTICULAR INSTALLATION.

Keithley Instruments, Incorporated

SAFETY PRECAUTIONS

The following safety precautions should be observed before using Model 236/237 Source Measure Units.

The Model 236/237 Source Measure Unit is intended for use by qualified personnel who recognize shock hazards and are familiar with the safety precautions required to avoid possible injury. Read over the operator's manual carefully before using the instrument.

Exercise extreme caution when a shock hazard is present. Lethal voltages may be present on the test fixture or the Source Measure Unit connector jacks. The American National Standards Institute (ANSI) states that a shock hazard exists when voltage levels greater than 30V RMS or 42.4V peak are present. A good safety practice is to expect that hazardous voltage is present in any unknown circuit before measuring.

Inspect the connecting cables, test leads, and jumpers for possible wear, cracks, or breaks before each use.

For maximum safety, do not touch the Source Measure Unit, test fixture, test cables or any other instruments while power is applied to the circuit under test. Turn off all power and discharge any capacitors before connecting or disconnecting cables or jumpers. Also, keep the test fixture lid closed while power is applied to the device under test. Safe operation requires the use of the lid interlock.

Do not touch any object which could provide a current path to the common side of the circuit under test or power line (earth) ground. Always make measurements with dry hands while standing on a dry, insulated surface capable of withstanding the voltage being measured.

Do not exceed the maximum signal levels of the test fixture, as shown on the rear panel and as defined in the specifications and operation section of the instruction manual.

Connect the  screw of the test fixture to safety earth ground using #18 AWG or larger wire (supplied accessory).

Instrumentation and accessories should not be connected to humans.

The  symbol on a Model 237 indicates that 1000V or more may be present on the terminals. Refer to the Model 236/237 Operator's Manuals for detailed operation information.

When a Model 236/237 is programmed for remote sensing, hazardous voltage may be present on the SENSE and OUTPUT terminals when the unit is in operate regardless of the programmed voltage or current. To avoid a possible shock hazard, always turn off all power before connecting or disconnecting cables to the Source Measure Unit or the associated test fixture.

PRÉCAUTIONS DE SÉCURITÉ

Il faut observer les précautions de sécurité suivantes avant d'utiliser les appareils de mesure de source 236/237/238.

L'appareil de mesure de source du modèle 236/237/238 doit être utilisé par des personnes qualifiées qui reconnaissent les risques d'électrocution et sont familières avec les précautions de sécurité nécessaires pour éviter des blessures possibles. Il faut lire le manuel de l'opérateur avec soin avant d'utiliser l'instrument.

Il faut faire extrêmement attention quand il y a des risques d'électrocution. Des tensions mortelles peuvent être présentes dans le dispositif de test ou dans les fiches de connecteurs de l'appareil de mesure de source. L'institut National Américain des Normes (ANSI) dit qu'il y a un risque d'électrocution quand des tensions supérieures à 30 V RMS ou 42,4 V de pointe sont présentes. **Une bonne habitude de sécurité est de s'attendre à des tensions dangereuses avant de mesurer un circuit inconnu.**

Avant chaque utilisation, il faut vérifier que les câbles de connexion, les cordons de test et les fils de connexion ne soient pas usés, fissurés ou cassés.

Pour le maximum de sécurité, ne pas toucher les connecteurs, le dispositif de test ou les câbles de test de l'appareil de mesure de source ou tout autre connecteur d'instrument quand le circuit à essayer est sous tension. Mettre sur l'arrêt toutes les alimentations et décharger tous les condensateurs avant de brancher ou débrancher les câbles ou les fils. Il faut aussi maintenir fermé le couvercle du dispositif de test pendant le test de l'appareil. Il faut verrouiller le couvercle pour obtenir une utilisation sans danger.

Ne pas toucher n'importe quel objet qui pourrait fournir un passage au côté commun du circuit à essayer ou à la masse de l'alimentation. Il faut toujours faire les mesures avec des mains sèches en se tenant sur une surface sèche et isolée capable de supporter la tension à mesurer.

Ne pas dépasser les niveaux maximum de signaux de l'instrument, comme montré sur le panneau arrière et comme indiqué dans la section des données techniques et des opérations du manuel de l'instrument.

Les instruments et les accessoires ne doivent pas être branchés sur des personnes.

Le symbole  sur le modèle 237 indique que 1000 V ou plus peuvent être présents dans les terminaux.

Avec le détecteur éloigné en marche, un cordon de détection ouvert peut produire des tensions mortelles à OUTPUT HI et GUARD. Cette tension peut causer des blessures ou la mort et endommager les circuits extérieurs. Il faut toujours s'assurer que les cordons de détection soient correctement branchés avant de mettre en marche le détecteur éloigné. NE JAMAIS changer les branchements sous tension. Il faut s'assurer de toujours décharger et/ou débrancher les sources externes d'alimentation.

Pour les dispositifs de test à plusieurs appareils verrouillés, il faut garder tous les modèles 236/237/238 soit tous en marche ou soit tous arrêtés.

SOMMAIRE DES COMMANDES

LOCAL (LOCAL) : Met l'appareil en fonctionnement local et rétablit le fonctionnement des touches du panneau frontal.

GROUPE DE SOURCE

OPERATION (OPERATE) : Met l'appareil en position de fonctionnement ou d'attente.

MESURE SOURCE (SOURCE MEASURE) : Choisit la tension de source et mesure l'intensité ou choisit l'intensité de la source et mesure la tension.

FONCTION (FUNCTION) : choisit le fonctionnement en courant continu ou en balayage.

CONFORMITÉ (COMPLIANCE) : Vérifie le niveau de conformité et mesure la plage. Change le niveau actuel et la plage en utilisant le commutateur rotatif ou le clavier, ensuite appuyer sur ENTER.

GROUPE DE MESURES

TEMPS (TIME) : Vérifie la période d'intégration. Change la sélection actuelle en appuyant sur les boutons de SELECT, ensuite appuyer sur ENTER.

SAUVEGARDE (SUPPRESS) : Sauvegarde la conversion suivante comme ligne de base. Les lectures suivantes seront la différence entre la valeur supprimée et le niveau réel du signal.

FILTRE (FILTER) : Affiche l'état du filtre de mesure. Change la quantité de filtration en appuyant sur les boutons de SELECT, ensuite sur ENTER.

AUTOPLAGE (AUTORANGE) : Permet à l'appareil de se mettre dans la plage avec la plus grande sensibilité pour faire une mesure.

GROUPE DE BALAYAGE

CREER (CREATE) : Choisit un balayage et définit ses paramètres. Utiliser les boutons de SELECT pour changer le type de balayage, ensuite appuyer sur ENTER. Utiliser le commutateur rotatif pour afficher les paramètres de balayage et le clavier pour les changer.

MODIFIER (MODIFY) : Affiche les valeurs de la source et de délais des points de balayage sauvegardés. Utiliser le bouton pour choisir le point de balayage, les boutons SELECT pour choisir la valeur de source et de délais, le clavier et ENTER pour changer les valeurs. Si la valeur de la source a changé, utiliser les boutons SELECT et ENTER pour changer la plage de la source.

AJOUT (APPEND) : Ajoute un balayage à un balayage existant. Appuyer sur APPEND fait afficher le balayage actuel et ses paramètres. Utiliser les boutons SELECT pour changer le type de balayage, ensuite appuyer sur ENTER. Utiliser le commutateur rotatif pour afficher les paramètres de balayage et le clavier pour les changer.

RAPPEL (RECALL) : Affiche les paramètres de la source, les valeurs des mesures et la durée pour chaque point de balayage. Utiliser le commutateur rotatif pour choisir le point et les boutons SELECT pour afficher les paramètres. Affiche seulement les valeurs de la source et du délais avant de faire le balayage.

GROUPE DE DÉCLENCHEMENT

PRÉPARATION (SETUP) : Vérifie l'état actuel du déclenchement. Utiliser le commutateur rotatif pour afficher les paramètres, les touches SELECT et ENTER pour changer les paramètres.

MANUEL (MANUAL) : Le voyant de déclenchement MANUAL clignotant indique qu'une stimulation de déclenchement est nécessaire (appuyer sur le bouton MANUAL, une commande de déclenchement sur le bus IEEE-488 ou une entrée externe de déclenchement).

GROUPE D'ENTRÉE DE DONNÉES

Commutateur rotatif : Commande l'affichage de différents paramètres de fonctionnement, règle les valeurs de la source et de conformité, et quand en RECALL, commande l'affichage des données de balayage.

CHOIX (SELECT) : Ces boutons choisissent les paramètres de fonctionnement de remplacement et, quand en RECALL, commandent l'affichage des données de balayage.

Clavier : Toutes les touches du clavier (sauf MENU) entrent ou annulent les données numériques.

MENU (MENU) : Utilisé pour vérifier ou changer les conditions suivantes de fonctionnement: délais du courant continu (0 à 65 secondes), délais d'implicite (marche/arrêt), détection (locale/éloignée), fréquence de l'alimentation (50 Hz/60 Hz) et l'adresse IEEE-488 (0 à 30 secondes). Aussi utilisé pour faire les auto-tests.

Branchements typiques

Branchements de détection locale en utilisant le dispositif de test modèle 8006

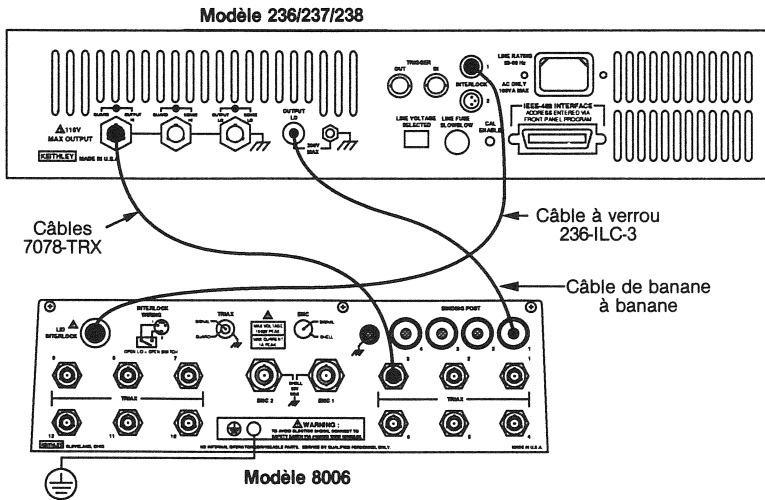

ATTENTION : Brancher à une masse de sécurité.

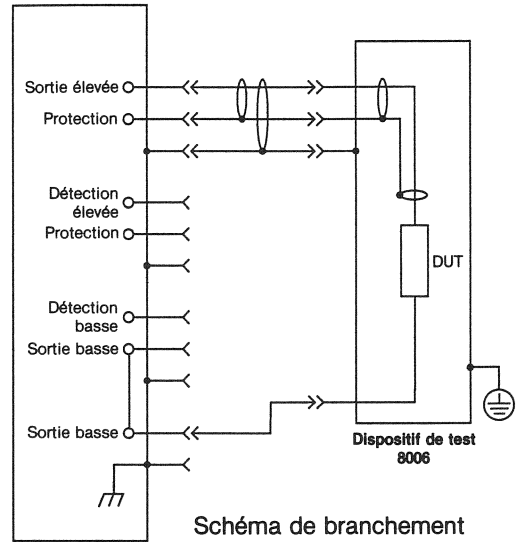

236/237/238

Branchements de détection éloignée en utilisant un dispositif de test modèle 8006

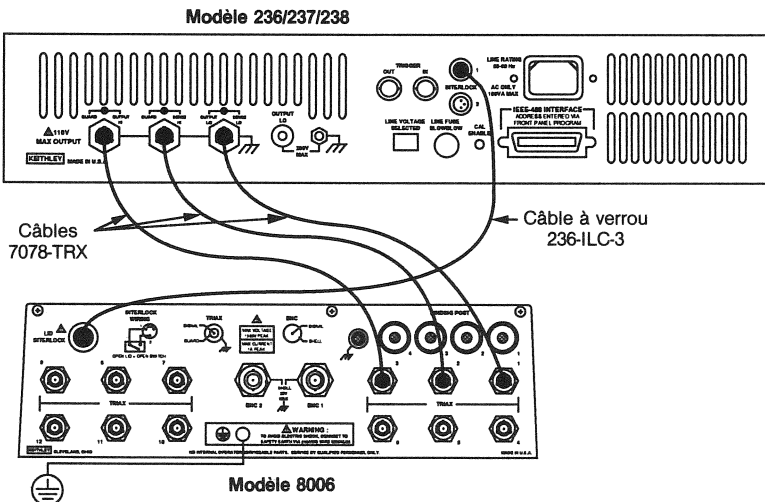

ATTENTION : Brancher à une masse de sécurité.

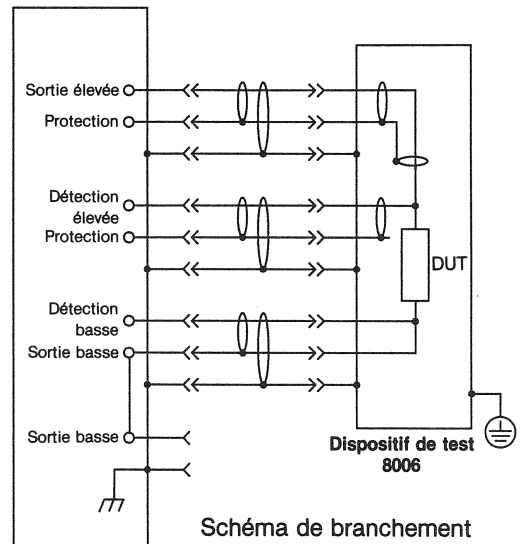

236/237/238

Circuits équivalents

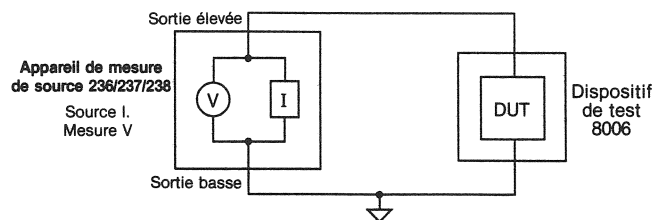
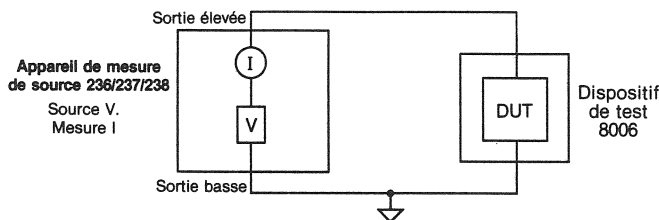

SICHERHEITSHINWEISE

Vor dem Gebrauch der Quellenmeßgeräte Modelle 236/237/238 beachten Sie bitte folgende Sicherheitshinweise.

Das Quellenmeßgerät Modell 236/237/238 ist für den Gebrauch durch qualifiziertes Personal gedacht, das eine Stromschlaggefahr erkennt und mit den Sicherheitsvorkehrungen vertraut ist, die zur Verhinderung einer möglichen Verletzung getroffen werden müssen. Vor dem Gebrauch des Gerätes lesen Sie bitte das Bedienerhandbuch sorgfältig durch.

Bei bestehender Stromschlaggefahr lassen Sie bitte äußerste Vorsicht walten. An der Testvorrichtung oder den Anschlüssen des Quellenmeßgerätes sind möglicherweise tödliche Spannungen vorhanden. Das American National Standard Institute (ANSI) weist darauf hin, daß eine Stromschlaggefahr dann besteht, wenn die Spannungswerte höher als 30 Volt RMS oder 42,4 Volt Spitzenleistung betragen. **Eine gute Sicherheitsmaßnahme ist die Vermutung, daß in jedem unbekanntem Stromkreis vor dem Messen eine gefährliche Spannung besteht.**

Prüfen Sie vor jeder Benutzung alle Verbindungskabel, Prüfkabel und Brücken auf mögliche Abnutzung, Risse oder Brüche.

Berühren Sie zur maximalen Sicherheit nicht die Quellenmeßgeräteschlüsse, Prüfvorrichtungen, Prüfkabel oder Verbindungen zu anderen Geräten, während der zu prüfende Stromkreis mit Strom versorgt wird. Stellen Sie den Strom ab und entladen Sie alle Kondensatoren, bevor Sie Kabel oder Brücken anschließen oder trennen. Halten Sie außerdem den Testanschlußdeckel geschlossen, während das zu prüfende Gerät mit Strom versorgt wird. Der sichere Betrieb erfordert die Benutzung des Deckelschlusses.

Berühren Sie keinen Gegenstand, der eine Stromleitung zur gemeinsamen Seite des zu prüfenden Stromkreises oder der Stromkabelmasse darstellt. Nehmen Sie die Messungen immer mit trockenen Händen vor, während Sie auf einer trockenen, isolierten Oberfläche stehen, die für die zu messende Spannung ausgelegt ist.

Überschreiten Sie nicht die auf der Rückseite des Gerätes vorgegebenen Höchstwerte, die außerdem im Kapitel "Technische Daten und Betrieb" des Bedienerhandbuchs beschrieben sind.

Geräte und Zubehör sollten nicht mit Menschen verbunden sein.

Das  Zeichen auf einem Modell 237 weist darauf hin, daß an diesen Anschlüssen mehr als 1000V vorhanden sein können.

Ist die ferngesteuerte Erfassung aktiviert, so führt ein offener Erfassungsdraht zu tödlichen Spannungen bei OUTPUT HI und GUARD. Diese Spannung kann Verletzungen oder den Tod herbeiführen und die externen Teile des Stromkreises beschädigen. Achten Sie immer darauf, daß die Erfassungsdrähte richtig angeschlossen sind, bevor Sie die ferngesteuerte Erfassung aktivieren. Ändern Sie die Anschlüsse NIEMALS unter Stromspannung. Achten Sie darauf, daß Sie externe Stromquellen immer entladen und/oder trennen.

Bei Prüfsystemen für mehrfache, miteinander verbundene Geräte stellen Sie entweder alle Modelle 236/237/238 an oder ab.

KONTROLLBEGRIFFE

LOKAL (LOCAL): Bringt Gerät in Lokal-Modus und stellt Frontabdeckungstastenfunktion wieder her.

QUELLENGRUPPE

BETRIEB (OPERATE): Bringt Gerät in Betrieb oder Standby.

QUELLENMESSUNG (SOURCE MEASURE): Bestimmt Quellenspannung und Meßstrom oder Quellenstrom und Meßspannung.

FUNKTION (FUNCTION): Bestimmt Gleichstrom oder Durchlaufbetrieb.

ÜBEREINSTIMMUNG (COMPLIANCE): Prüft die Stufe der Übereinstimmung und den Meßbereich. Sie ändern die gegenwärtige Stufe oder den Bereich, indem Sie den Drehknopf oder das Tastenfeld bedienen und dann ENTER drücken.

MESSGRUPPE

ZEIT (TIME): Prüft Integrationszeitraum. Sie ändern die gegenwärtige Einstellung, indem Sie einen der SELECT Knöpfe betätigen und dann ENTER drücken.

UNTERDRÜCKEN (SUPPRESS): Speichert nächste Umwandlung als Grundwert. Alle folgenden Ablesungen sind dann die Differenz zwischen dem unterdrückten Wert und dem tatsächlichen Signalwert.

FILTER (FILTER): Gibt Status des Meßfilters wieder. Sie ändern den Wert, indem Sie einen der SELECT Knöpfe betätigen und ENTER drücken.

AUTOBEREICH (AUTORANGE): Ermöglicht es dem Gerät, den empfindlichsten Bereich für die vorzunehmende Messung zu wählen.

DURCHLAUFGRUPPE

BESTIMMEN (CREATE): Bestimmt einen Durchlauf und dessen Parameter. Bedienen Sie sich der SELECT Knöpfe, um die Durchlaufart zu ändern und drücken Sie dann ENTER. Benutzen Sie den Drehknopf, um die Durchlaufparameter anzuzeigen und das Tastenfeld, um sie zu ändern.

ÄNDERN (MODIFY): Zeigt Quellen- und Verzögerungswerte der gespeicherten Durchlaufpunkte an. Benutzen Sie den Knopf, um den Durchlaufpunkt zu bestimmen; die SELECT Knöpfe, um die Quellen- oder Verzögerungswerte zu bestimmen, und das Tastenfeld und ENTER, um die Werte zu ändern. Wurde der Quellenwert geändert, so benutzen Sie die SELECT Knöpfe und ENTER, um den Quellenbereich zu ändern.

ANHANG (APPEND): Fügt einem bereits existierenden Durchlauf einen weiteren hinzu. Drücken Sie APPEND, so erscheint der gegenwärtige Durchlauf und dessen Parameter. Benutzen Sie die SELECT Knöpfe, um die Durchlaufart zu ändern und drücken Sie dann ENTER. Benutzen Sie den Drehknopf, um die Durchlaufparameter anzuzeigen und das Tastenfeld, um sie zu ändern.

RÜCKRUF (RECALL): Zeigt Quellenparameter, Meßwerte und verstrichene Zeit für jeden Durchlaufpunkt an. Benutzen Sie den Drehknopf, um den Punkt zu bestimmen und die SELECT Knöpfe zur Wiedergabe der Parameter. Zeigt nur Quellen- und Verzögerungswerte vor dem Durchlauf an.

AUSLÖSERGRUPPE

VORGABEN (SETUP): Prüft gegenwärtigen Triggerstatus. Benutzen Sie den Drehknopf zur Anzeige der Parameter und die SELECT und ENTER Tasten zur Änderung der Parameter.

HANDBETRIEB (MANUAL): Eine leuchtende MANUAL Triggerleuchte zeigt an, daß ein Triggerimpuls nötig ist (Druck auf den MANUAL Knopf, Triggerbefehl über IEEE-488 Vielfachleitung oder externer Eingabetrigger).

DATENEINGABEGRUPPE

Drehknopf: Regelt die Anzeige verschiedener Betriebsparameter, stellt Quellen- und Übereinstimmungswerte ein und regelt — wenn im RECALL-Modus — die Anzeige der Durchlaufdaten.

WAHL (SELECT): Mit diesen Knöpfen werden andere Betriebsparameter gewählt und — wenn im RECALL-Modus — die Anzeige der Durchlaufdaten geregelt.

Tastenfeld: Alle Tastenfeldknöpfe (mit Ausnahme von MENÜ/MENU) geben numerische Daten ein oder löschen diese.

MENÜ (MENU): Dient dazu, folgende Betriebsbedingungen zu prüfen oder zu ändern: Gleichstromverzögerung (0 bis 65 sek), Grundeinstellungsverzögerung (an/aus), Erfassung (lokal/ferngesteuert), Frequenz (50 Hz/60 Hz) und IEEE-488 Adresse (0 bis 30). Dient auch zur Durchführung von Selbstprüfungen.

Gebräuchliche Anschlüsse

Lokale Erfassungsanschlüsse bei Verwendung von Modell 8006 Prüfgerät

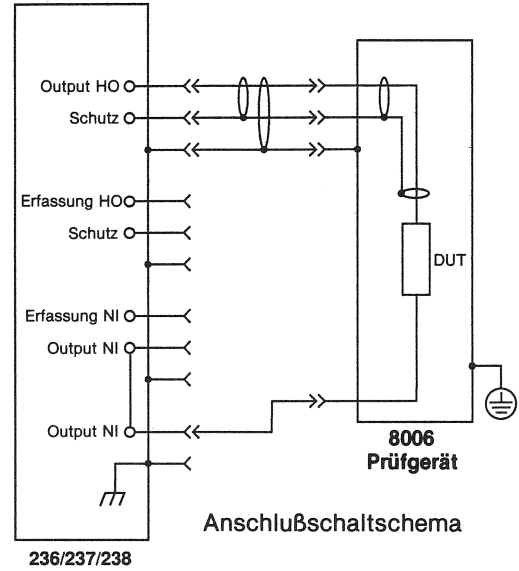
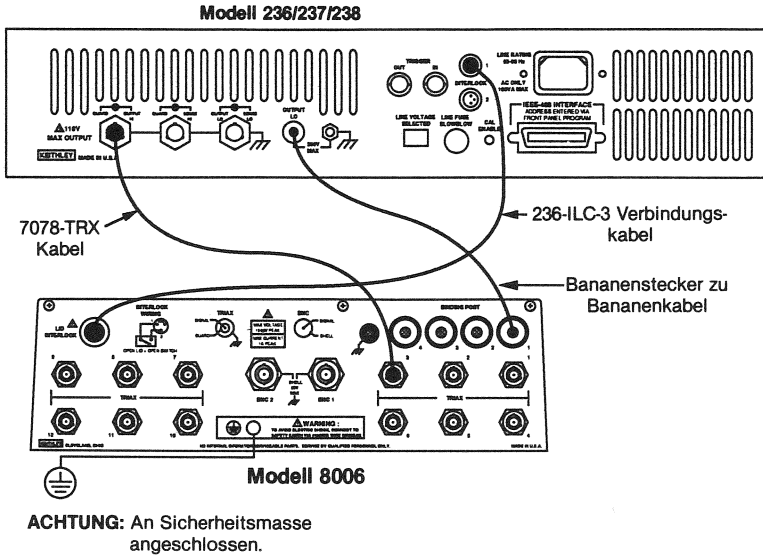

Ferngesteuerte Erfassungsanschlüsse bei Verwendung von Prüfgerät Modell 8006

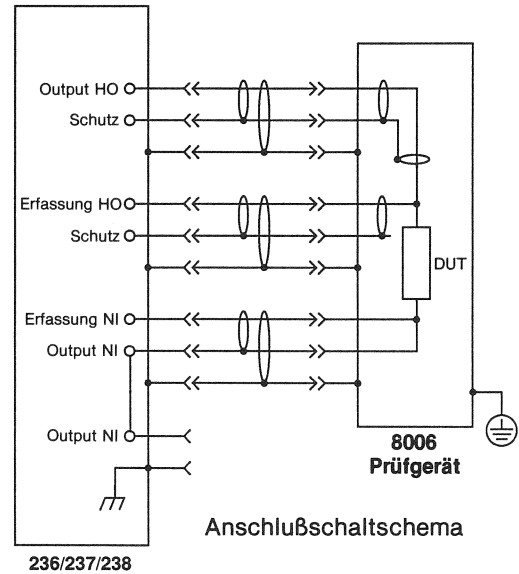
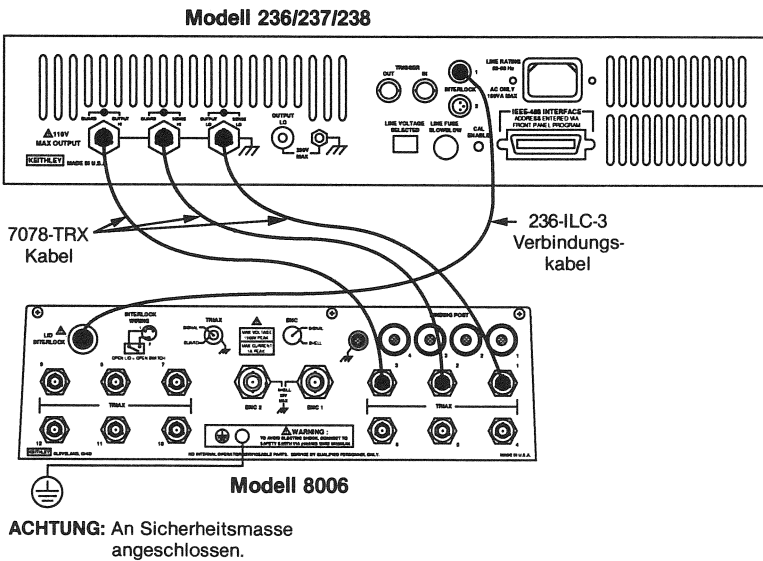

Äquivalente Stromkreise

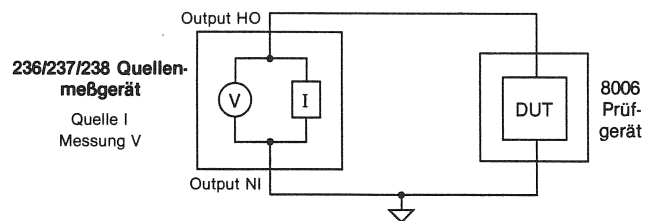
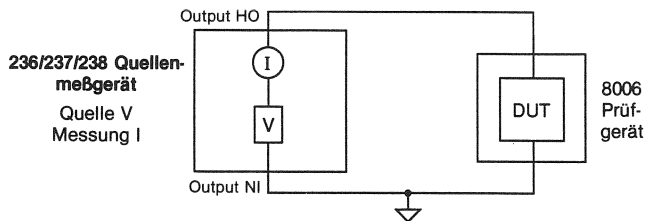

PRECAUZIONI DI SICUREZZA

Bisogna osservare le seguenti precauzioni di sicurezza prima di usare gli apparecchi di misura di sorgente 236/237/238.

L'apparecchio di misura di sorgente tipo 236/237/238 dovrà essere utilizzato da personale qualificato in grado di riconoscere i rischi d'elettrocuzione e sono al corrente delle precauzioni di sicurezza necessarie per evitare eventuali danni alla persona. Bisogna leggere con attenzione il manuale dell'operatore prima d'utilizzare l'apparecchio.

È necessario procedere con estrema attenzione quando vi sono rischi d'elettrocuzione. Potrebbero esservi delle tensioni letali nell'apparecchio di prova o nei connettori dell'Apparecchio di misura di sorgente. Secondo l'Istituto nazionale americano dei regolamenti (ANSI), c'è rischio d'elettrocuzione allorché vi sono livelli massimi di voltaggio superiori a 30 V RMS o 42, 4 V. **È buona abitudine di sicurezza attendersi chi vi siano tensioni pericolose prima di misurare un circuito sconosciuto.**



Prima dell'uso è necessario verificare che i cavi di connessione, i conduttori di prova ed i ponti non accusino tracce di usura, incrinature o avarie.

Per un massimo di sicurezza, non toccare i connettori dell'apparecchio di misura di sorgente, l'apparecchio di prova, i cavi di prova o alcun altro connettore quando il circuito di prova è sotto tensione. Interrompere completamente l'alimentazione e scaricare tutti i condensatori prima di allacciare o slacciare cavi e ponti. Bisogna inoltre tenere chiuso il coperchio dell'apparecchio di prova allorché il dispositivo in prova è sotto tensione. L'uso del dispositivo di sicurezza sul coperchio garantisce un'operazione priva di pericoli.

Non toccare alcun oggetto che potrebbe fornire un passaggio di tensione al lato comune del circuito in prova o alla massa. I rilevamenti vanno sempre effettuati con le mani asciutte rimanendo su superfici asciutte ed isolate, capaci di sostenere la tensione che si vuole misurare.

Non superare i livelli massimi dei segnali dell'apparecchio, come indicato sul pannello posteriore e come definito nella sezione specifiche ed uso del manuale d'istruzione.

Gli strumenti e gli accessori non vanno allacciati alla persona.

 Il simbolo  sul modello 237 sta ad indicare che sui terminali potrebbe esservi una tensione superiore ai 1000 V.

Col telesensore attivato, un conduttore di sensore aperto è in grado di produrre delle tensioni letali a OUTPUT HI e GUARD. Tale tensione può causare lesioni o morte e danneggiare i circuiti esterni. Accertarsi sempre che i conduttori di sensore siano appositamente allacciati prima di attivare il telesensore. Non sostituire MAI i connettori sotto tensione. Accertarsi di scaricare e/o slacciare sempre le sorgenti di tensione esterne.

Per i dispositivi di prova ad apparecchi multipli, sarà necessario tenere tutti i modelli 236/237/238 in funzione o fermarli tutti.

SOMMARIO DEI COMANDI

LOCALE (LOCAL): Avvia l'apparecchio in funzionamento locale e ristabilisce il funzionamento a tasti del pannello anteriore.

GRUPPO DELLA SORGENTE

OPERAZIONE (OPERATE): Mette l'apparecchio in funzione o in posizione d'attesa.

MISURA DELLA SORGENTE (SOURCE MEASURE): Sceglie la tensione della sorgente e ne misura l'intensità, o sceglie l'intensità della sorgente e misura la tensione.

FUNZIONE (FUNCTION): Sceglie il funzionamento a corrente continua o a scansione.

CONFORMITÀ (COMPLIANCE): Verifica il livello di conformità e misura la gamma. Cambiare il livello e la gamma attuali agendo sul commutatore rotatorio o sul tasto, quindi premere ENTER.

GRUPPO DI MISURA

TEMPO (TIME): Verifica il periodo d'integrazione. Cambiare la selezione attuale agendo su pulsante SELECT, quindi su quello ENTER.

PROTEZIONE (SUPPRESS): Protegge la conversione seguente come linea di base. Le leggende successive consisteranno nella deferenza fra il valore soppresso ed il livello reale del segnale.

FILTRO (FILTER): Indica lo stato del filtro di misura. Cambiare il quantitativo di filtraggio agendo sul pulsante SELECT, quindi su quello ENTER.

AUTOGAMMA (AUTORANGE): Permette all'apparecchio di porsi sulla gamma più sensibile per effettuare la misura.

GRUPPO DI SCANSIONE

CREARE (CREATE): Sceglie una scansione e ne definisce i parametri. Servirsi dei pulsanti SELECT per cambiare il tipo di scansione, quindi premere ENTER. Servirsi del commutatore rotatorio per indicare i parametri e la tastiera per cambiarli.

MODIFICARE (MODIFY): Indica i valori della sorgente e del ritardo dei punti di scansione protetti. Servirsi del commutatore rotatorio per scegliere il punto di scansione, i pulsanti SELECT per scegliere il valore della sorgente o del ritardo, la tastiera ed ENTER per cambiare i valori. Se il valore della sorgente è mutato, agire sui pulsanti SELECT ed ENTER per cambiare la gamma della sorgente.

AGGIUNGERE (APPEND): Aggiunge una scansione ad una scansione esistente. Premendo l'APPEND vengono indicati la scansione attuale ed i suoi parametri. Servirsi dei pulsanti SELECT per cambiare il tipo di scansione, quindi premere ENTER. Servirsi del commutatore rotatorio per indicare i parametri e la tastiera per cambiarli.

RICHIAMO (RECALL): Indica i parametri della sorgente, i valori di misura, ed il tempo trascorso per ciascun punto di scansione. Servirsi del commutatore rotatorio per scegliere un punto e dei pulsanti SELECT per indicare i parametri. Indica soltanto i valori della sorgente e del ritardo prima di effettuare la scansione.

GRUPPO DI SGANCIO

PREPARAZIONE (SETUP): Verifica lo stato attuale dello sgancio. Servirsi del commutatore rotatorio per indicare i parametri, e dei tasti SELECT ed ENTER per cambiare i parametri.

MANUALE (MANUAL): Il lampeggiare della spia di sgancio MANUAL sta ad indicare la necessità di uno stimolo di sgancio (premere pulsante MANUAL, comando di sgancio sulla sbarra IEEE-488, o sgancio a comando estero).

GRUPPO D'IMMISSIONE DATI

Commutatore rotatorio: Comanda l'indicazione di vari parametri di funzionamento, regola i valori della sorgente e di conformità e, nella posizione di RECALL, comanda l'indicazione dei dati di scansione.

SELEZIONE (SELECT): Tali pulsanti scelgono i parametri di funzionamento alterni e, nella posizione di RECALL, comandano l'indicazione dei dati di scansione.

Tastiera: Tutti i tasti della tastiera (eccetto il MENU) immettono o cancellano i dati numerici.

MENU (MENU): Viene utilizzato per verificare o cambiare le seguenti condizioni di funzionamento: ritardo della corrente continua (0 a 65 secondi), ritardo per default (avvio/arresto), sensore (locale/a distanza), frequenza di alimentazione (50Hz/60Hz), e l'indirizzo IEEE-488 (0 a 30 secondi). Utilizzati anche per effettuare auto-prove.

Allacciamenti tipici

Allacciamenti sensore locale utilizzando apparecchio di prova Modello 8006

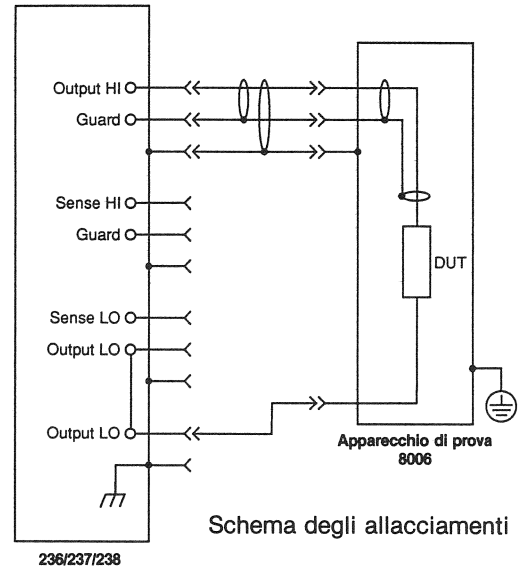
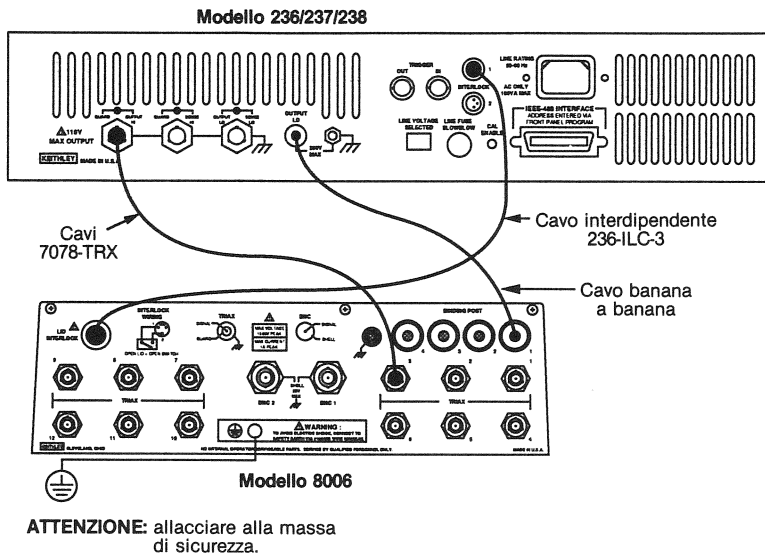

Allacciamenti sensore a distanza utilizzando apparecchio di prova Modello 8006

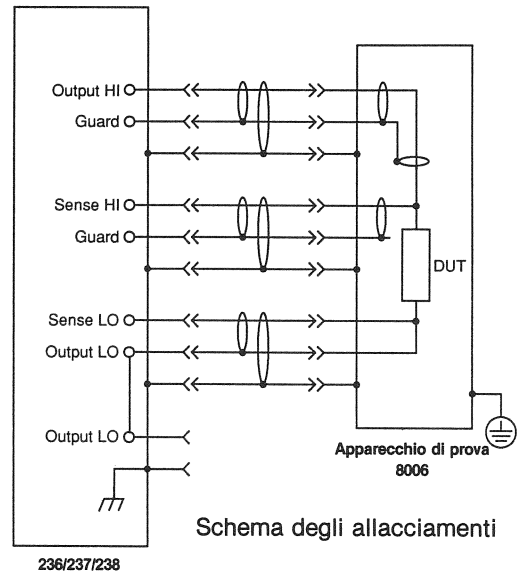
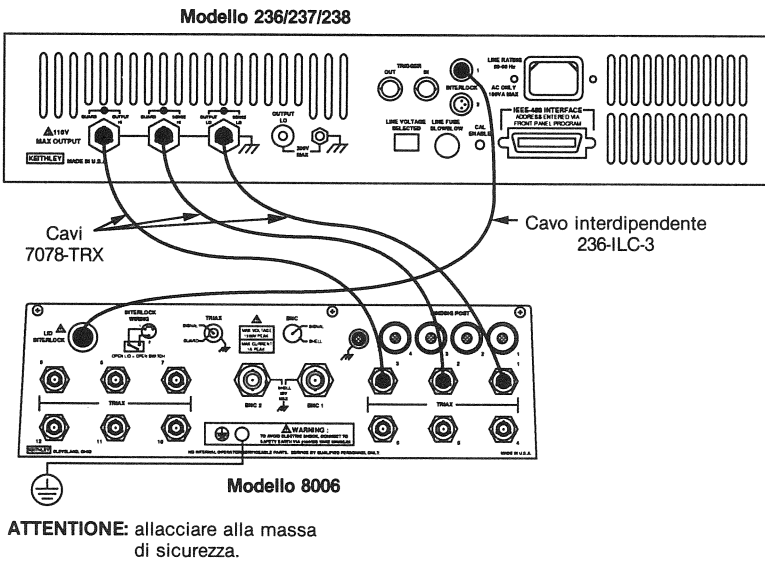

Circuiti equivalenti

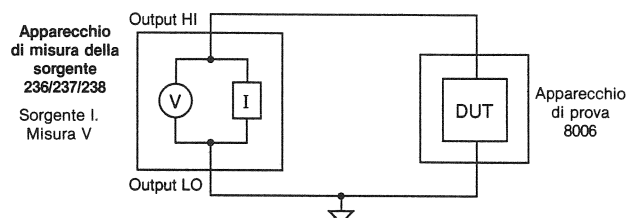
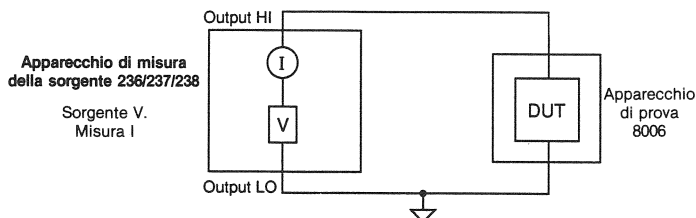

安全に関する注意

モデル236/237/238の供給元測定器を使用する前に、次に示す安全に関する注意をお読みください。

モデル236/237/238の供給元測定器は、怪我の可能性を避けるために必要な安全予防または感電に関して十分な知識をもった有資格者によって使用されるように意図されています。器具を使用する前にオペレーター・マニュアルを必ずお読みください。

感電の危険性がある場合には、特に注意してください。致命的な電圧がテスト取付具や供給元測定器の接続プラグにかかっているかもしれません。アメリカ・ナショナル・スタンダード・インスティテュート(ANSI)は、電圧が30V RMS かピーク電圧が42.4V以上なら、感電の危険性があると述べています。測定する前に未知の回路には、危険な電圧がかかっていると疑ってみることも安全対策の一つです。

毎回使用する前に、かならず接続線、テスト用電線、そしてジャンプ線がすり減ったり、あるいはひびや切断がないかを確認してください。

安全性を守るため、テスト中に電気がつながっている間、供給元測定器の接続部、テスト取付具、テスト用電線、または他の接続部には絶対に触れないでください。電線の接続、切断やジャンプをする前に、全ての電気を止めてコンデンサを放電させて下さい。また、テスト中には、装置に送電している時はテスト取付具のふたを閉めたままにしてください。

テスト中に回路の共通部に電気回路を供給するものや電気アース線に触れないでください。また、測定電圧に耐える乾燥状態の絶縁体は、常にかわいた手で測定してください。

後ろにあるパネル、仕様書、そしてインストラクション・マニュアルのオペレーション・セクションに記載されているように、器具の最大シグナルを越えないでください。

器具や付属品を人に接続しないでください。

モデル237にある  のシンボルは、端子に1000ボルト以上の電圧がかかっている可能性があるということを提示しています。

リモートセンサーを使うと、オープンセンスの電線は、アウトプット HI とガードに致命的な電圧を引き起こします。この電圧は、怪我や死亡、そして外部の回路を破損する原因になります。リモートセンスを可能にする前に、センスの電線が正しく接続されているかを常に確認してください。電気が流れている状態では、決して接続をかえないでください。常に放電をして、外部の電源を止めてください。

並列ユニット・インターロックのテスト・システムのためには、すべてのモデル236/237/238の電気をONか、あるいはすべてをOFFにしておいて下さい。

コントロールに関する要約

ローカル (LOCAL): ユニットのローカルにして、前部のパネルのキー・オペレーションをもとに戻します。

供給元 (ソース) グループ

オペレート (OPERATE): ユニットをオペレート、あるいはスタンバイにします。

供給元測定 (SOURCE MEASURE): ソース電圧と測定電流、またはソース電流と測定電圧のどちらかを選択します。

ファンクション (FUNCTION): 直流またはスウィープを選択します。

コンプライアンス (COMPLIANCE): コンプライアンスのレベルをチェックして、レンジを測定します。現在のレベルとレンジを回転式のつまみかキーボードを使って変えて、エンターを押してください。

測定グループ

タイム (TIME): インテグレーションの期間をチェックします。現在の選択をセレクトのボタンを押してかえ、エンターを押してください。

サプレス (SUPPRESS): ベースラインとして次の転換を記憶します。その後の測定値は、削除した値と実際のシグナルレベルと異なります。

フィルター (FILTER): 測定フィルターの状態を表示します。セレクト・ボタンを押して、フィルターの量を変えて、エンターを押します。

オートレンジ (AUTORANGE): ユニットの測定する最も感度の高いレンジにすることができます。

スウィープ・グループ

クリエート (CREATE): スウィープを選択して、そのパラメーターを定義します。スウィープのタイプを変えるためにセレクト・ボタンを使って、エンターを押してください。スウィープ・パラメーターを表示するために回転つまみを使用し、そしてキーボードを使ってください。

モディファイ (MODIFY): ソースと記憶されているスウィープポイントの遅延値を表示します。スウィープポイントの選択はつまみを使用します。ソースや遅延値の選択には、セレクト・ボタンを押して下さい。また値の変更はキーボードとエンターを押して下さい。そしてソース値の変更は、セレクト・ボタンとエンターを使ってください。

アペンド (APPEND): スウィープに既に存在するスウィープを加えます。アペンドを押すと現在のスウィープとそのパラメーターを表示します。スウィープのタイプを変えるにはセレクト・ボタンを使って、そしてエンターを押します。スウィープのパラメーターを表示するには回転つまみとキーボードを使ってください。

リコール (RECALL): ソースパラメーター、測定値、そして各々のウィーブポイントの経過時間を表示します。ポイントの選択には回転つまみを、パラメーターの表示にはセレクト・ボタンを使ってください。リコールはスウィープが作動する前にソースと遅延値のみを表示します。

始動 (トリガー) グループ

セットアップ (SETUP): 現在のトリガー状態をチェックします。パラメーターの表示には回転つまみを、またパラメーターの変更にはセレクトキーとエンターキーを使ってください。

マニュアル (MANUAL): マニュアルのトリガーライトの点滅は、トリガーの刺激が必要であることを示しています。(マニュアルボタンを押して、IEEE-488バスか外部インプットトリガーにトリガーコマンド)

データー入力グループ

ロータリーノブ (Rotary Knob): いろいろなオペレーション・パラメーターの表示をコントロールし、ソースとコンプライアンス値を調節します。リコール状態では、スウィープ・データーの表示をコントロールします。

セレクト (SELECT): これらのボタンは、代わりにオペレーション・パラメーターを選択し、リコールの時にはスウィープデーターの表示をコントロールします。

キーボード (Keypad): すべてのキーボードのボタン(メニューを除く)は、数字データーの入力または削除を行います。

メニュー (MENU): 次のオペレーション状態をチェックしたり、変更するのに使用されます。DCの遅延(0から65秒)、デフォルトの遅延(オンかオフ)、センス(ローカル/リモート)、ライン周波数(50Hzか60Hz)、IEEE-488アドレス(0から30)。また自動テストにも使用されます。

典型的な接続

モデル8006 テスト固定具を使ってローカルセンスの接続

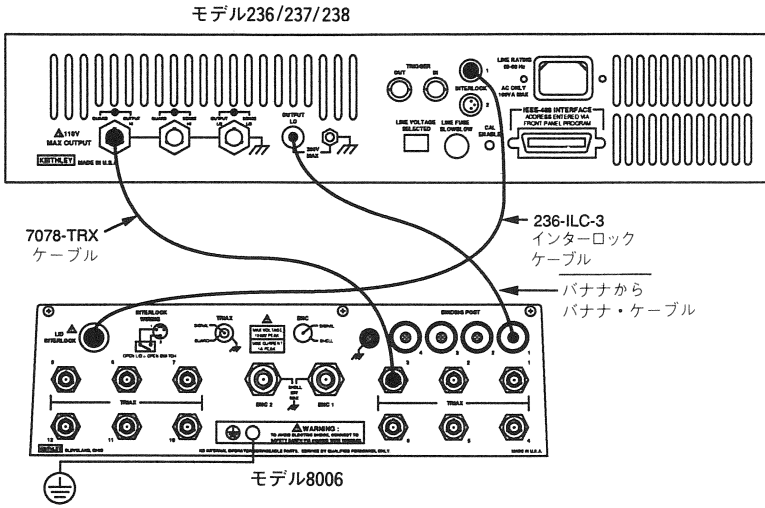

注意：安全にアースして下さい。

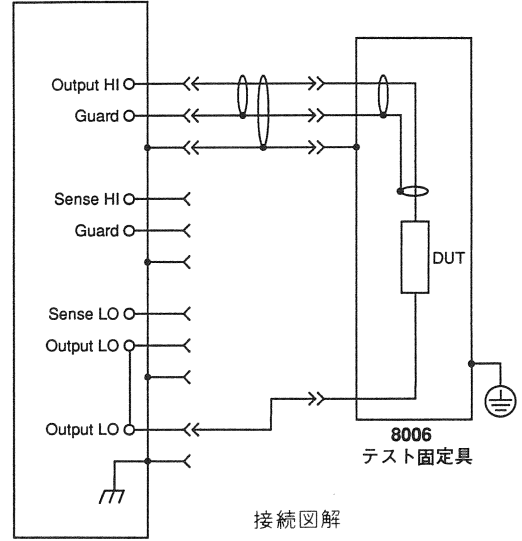

モデル8006 テスト固定具を使ってリモートセンスの接続

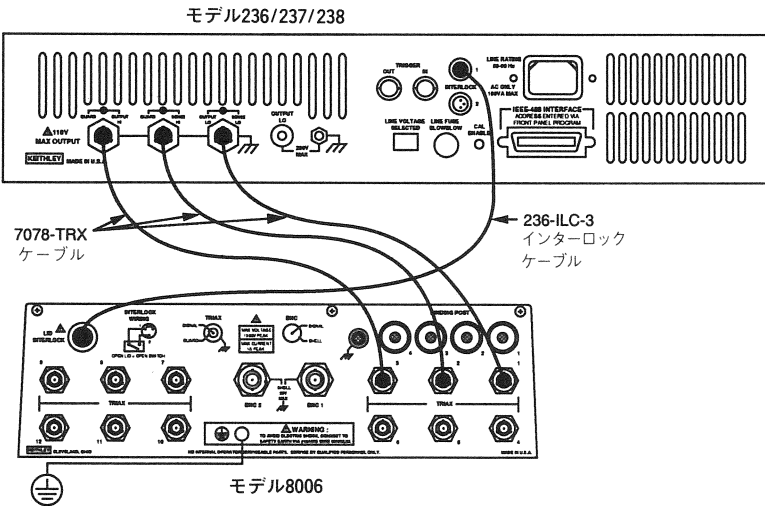

注意：安全にアースして下さい。

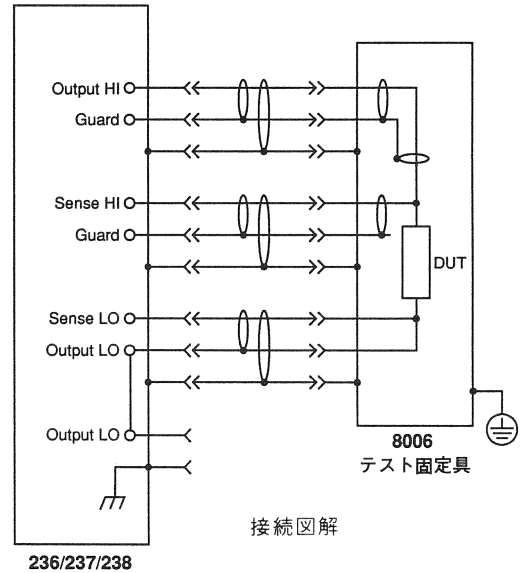

等価回路

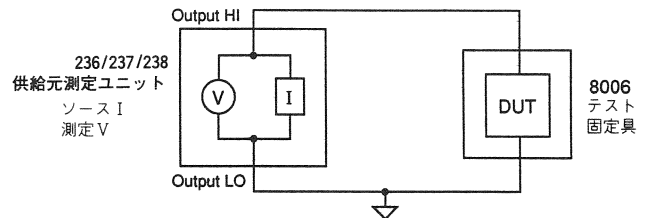
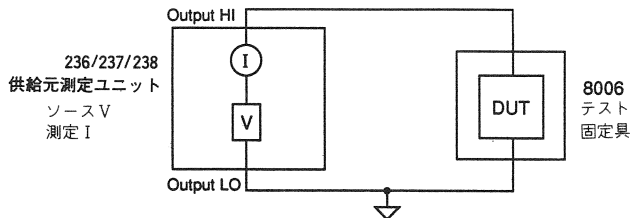

MEDIDAS DE SEGURIDAD

Es necesario tomar las medidas de seguridad antes de usar los aparatos medidores de fuente modelos 236/237/238.

El medidor modelo 236/237/238 está diseñado para ser usado por personal experimentado capaz de reconocer los peligros de los electrochoques y conocedor de las medidas de seguridad requeridas para evitar la posibilidad de sufrir lesiones. Leer el manual del operador cuidadosamente antes de usar este instrumento.

Tener sumo cuidado cuando exista peligro de electrochoque. Podría haber voltaje mortal presente en los enchufes conectores del probador o medidor de fuente. El Instituto de Normalizaciones Nacional Norteamericano (ANSI) establece que existe peligro de electrochoque cuando los niveles de voltaje son superiores a 30 V RMS o de cresta de 42,4V. **Una buena medida de seguridad es anticipar la presencia de voltajes peligrosos en cualquier circuito desconocido antes de tomar mediciones.**

Inspeccionar los cables de conexión, conductores de prueba y cables puente en busca de posible desgaste, grietas o roturas antes de cada uso.

Para máxima seguridad, no tocar los conectores del medidor, probador, cables de prueba o cualquier otro conector de instrumento mientras se aplica corriente eléctrica al circuito que se está probando. Cortar toda la corriente eléctrica y descargar los capacitores antes de conectar o desconectar cables o cables puente. También, mantener cerrada la tapa del probador mientras se aplica corriente al dispositivo que se está probando. La operación segura requiere el uso de un enclavamiento de la tapa.

No tocar ningún objeto que pudiera proporcionar un paso de corriente al lado común del circuito sometido a prueba o tierra del cable de energía eléctrica. Siempre tomar las mediciones con las manos secas de pie sobre una superficie seca y aislada capaz de resistir el voltaje que se está midiendo.

No exceder los niveles máximos de señal del instrumento, como se indica en el panel trasero y como se define en las especificaciones y sección de operación del manual de instrucciones.

No se deben conectar los instrumentos y accesorios a seres humanos.

El símbolo  que aparece en el modelo 237 indica que en los terminales puede haber presente 1000V o más.

Con el detector remoto habilitado, un conductor de detección abierto dará por resultado la aparición de voltajes mortales en la conexión de **SALIDA ALTA** y de **GUARDA (OUTPUT HI y GUARD)**. Este voltaje puede causar lesiones e incluso la muerte, y dañar los circuitos exteriores. Siempre asegurar que los conductores de detección estén bien conectados antes de habilitar el detector remoto. **NUNCA** cambiar las conexiones estando la energía eléctrica aplicada. Siempre asegurar de descargar y/o desconectar la fuentes de suministro de energía externas.

Para los sistemas de prueba interconectados de medidores múltiples, se deberá mantener ya sea todos los modelos 236/237/238 energizados, o todos desenergizados.

RESUMEN DE LOS CONTROLES

LOCAL (LOCAL): Pone el instrumento en local y restablece las operaciones del panel frontal.

GRUPO DE LA FUENTE

OPERAR (OPERATE): Pone la unidad en estado de funcionamiento o de reserva.

MEDIDA FUENTE (SOURCE MEASURE): Selecciona tensión primaria o de fuente y corriente de medida, o corriente de fuente y tensión de medida.

FUNCION (FUNCTION): Selecciona operación cc o de barrido.

DOCILIDAD (COMPLIANCE): Verifica el nivel de docilidad y el margen de medida. Cambiar el nivel y margen en curso con la ayuda de la perilla o teclado y luego pulsar ENTER.

GRUPO DE MEDICION

TIEMPO (TIME): Verifica el período de integración. Cambiar la selección en curso pulsando los botones SELECT (SELECCIONAR) y luego ENTER (ENTRAR).

SUPRIMIR (SUPPRESS): Guarda la conversión siguiente como una medición de línea de base. Las lecturas subsiguientes serán la diferencia entre el valor suprimido y el nivel real de la señal.

FILTRO (FILTER): Indica el estado del filtro de medición. Cambiar la cantidad de filtración pulsando los botones SELECT y luego ENTER.

AUTOGAMA (AUTORANGE): Permite al aparato pasar a la gama o margen más sensible para tomar una medida.

GRUPO DE BARRIDO

CREAR (CREATE): Selecciona un barrido y define sus parámetros. Usar los botones SELECT para cambiar el tipo de barrido y en seguida pulsar ENTER. Usar la perilla giratoria para visualizar los parámetros de barrido y el teclado para cambiarlos.

MODIFICAR (MODIFY): Visualiza los valores de retardo y de fuente de los puntos de barrido registrados en la memoria. Usar la perilla para elegir el punto de barrido, los botones SELECT para elegir el valor de fuente o de retardo, el teclado y la tecla ENTER para cambiar los valores. Si el valor de fuente cambió, usar los botones SELECT y ENTER para cambiar el margen de la fuente de energía.

AGREGAR (APPEND): Añade un barrido a un barrido ya existente. Al pulsar APPEND se visualiza el barrido en curso y sus parámetros. Usar los botones SELECT para cambiar el tipo de barrido y en seguida pulsar ENTER. Usar la perilla giratoria para visualizar los parámetros de barrido y el teclado para cambiarlos.

LLAMAR (RECALL): Visualiza los parámetros de la fuente, los valores de medición y el tiempo transcurrido para cada punto de barrido. Usar la perilla giratoria para elegir el punto y los botones SELECT para visualizar los parámetros. Visualiza los valores de fuente y de retardo solamente antes de ejecutarse el barrido.

GRUPO DE DISPARADORES

PREPARACION (SETUP): Verifica la condición o estado actual del disparador. Usar la perilla giratoria para visualizar los parámetros, las teclas SELECT y ENTER para cambiar los parámetros.

MANUAL (MANUAL): La luz destellante del disparador MANUAL indica que se requiere un impulso de disparo (pulsación del botón MANUAL, comando de disparo sobre la barra colectora o bus IEEE-488, o un disparador de entrada exterior).

GRUPO DE ENTRADA DE DATOS

Perilla giratoria: Controla la visualización de los distintos parámetros de operación, ajusta los valores de fuente y de docilidad, y cuando está en modo RECALL, controla la visualización de los datos de barrido.

SELECCIONAR (SELECT): Estos botones seleccionan los parámetros operacionales alternativos y, cuando está en modo RECALL, controlan la visualización de los datos de barrido.

Teclado: Todos los botones del teclado (excepto MENU) sirven para entrar (registrar) o anular datos numéricos.

MENU (MENU): Se usa para verificar o cambiar las siguientes condiciones de operación: retardo cc (0 a 65 segundos), retardo predeterminado por defecto (activado/desactivado), detección (local/remota), frecuencia de línea (50 Hz/60 Hz), y dirección IEEE-488 (0 a 30). También se usa para ejecutar autopuebas.

Conexiones típicas

Conexiones de detección local con el probador modelo 8006

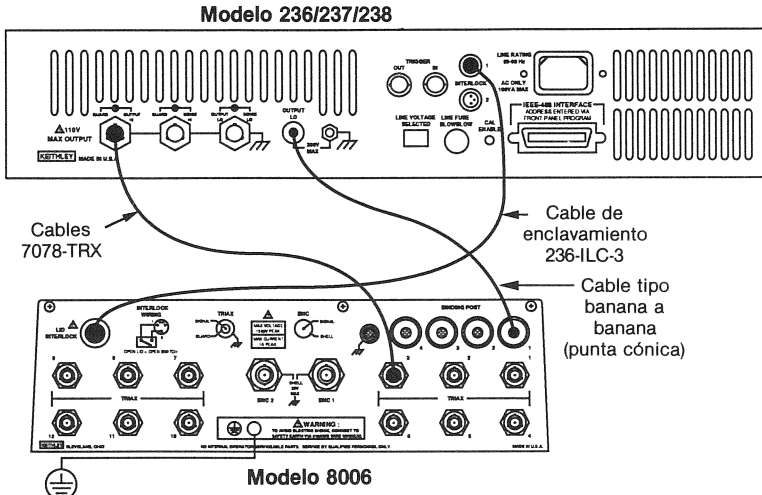

ADVERTENCIA: Conectar a una puesta a tierra segura.

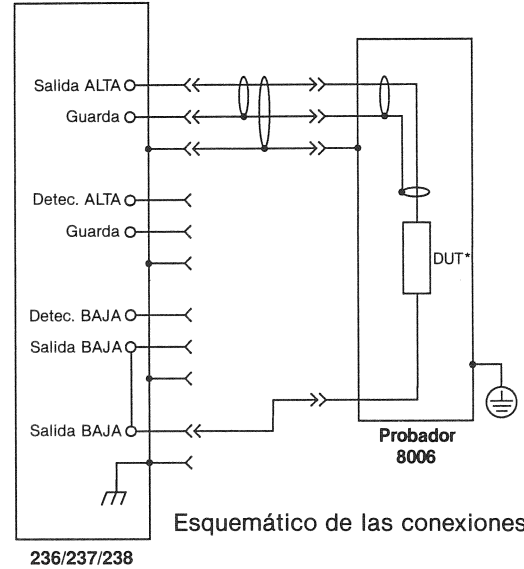

*DUT = Aparato en período de pruebas

Conexiones de detección remota con probador modelo 8006

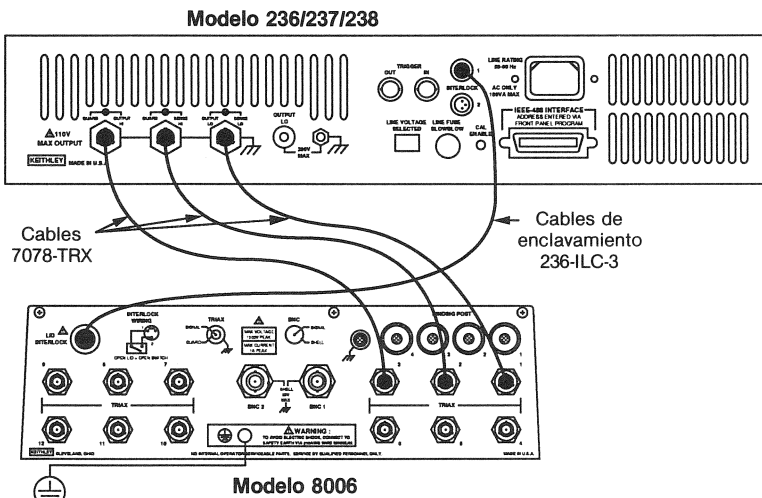

ADVERTENCIA: Conectar a una puesta a tierra segura.

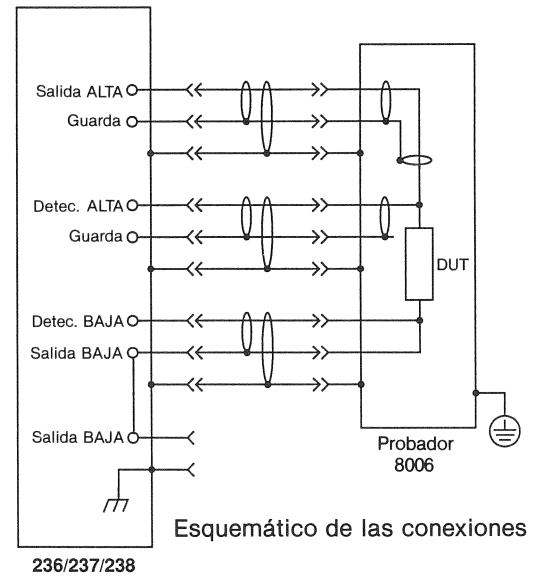

Circuitos equivalentes

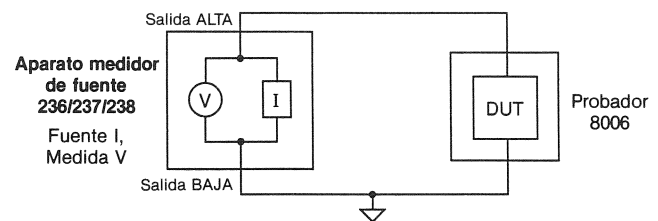
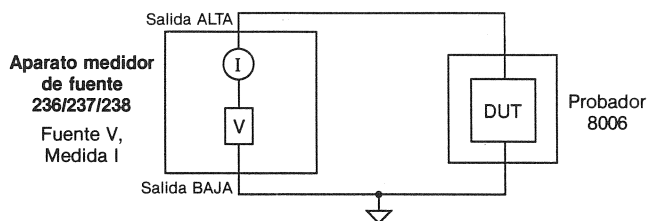

SPECIFICATIONS

SOURCE-MEASURE UNIT: Sources voltage while measuring current, or sources current while measuring voltage.

FUNCTION: Can be used as DC source or meter, sweep source, or full source-measure unit.

SOURCE-DELAY-MEASURE CYCLE:

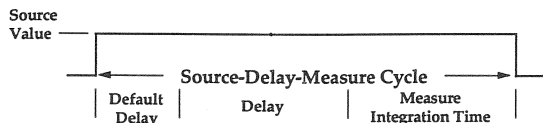

Default Delay: Fixed delay for instrument settling.

User Delay: Additional delay for device under test or system capacitance.

MEASURE:

Integration Time:

Fast	416	µsec.	4 digit resolution
Medium	4	msec.	5 digit resolution
Line Cycle	16.67	msec. (60 Hz)	5 digit resolution
	20.00	msec. (50 Hz)	

Elapsed Time: Measures and stores time from sweep trigger to measurement complete for each step of sweep.

RANGING:

Source: Auto-ranging through keypad entry; fixed range selection using rotary dial and SELECT keys (DC function). Fully programmable in SWEEP function.

Measure: Auto or fixed range. Fixed range selection made by choice of COMPLIANCE value.

FILTER: Takes n measurements, calculates and outputs average (n = 2, 4, 8, 16, or 32, selectable).

SUPPRESS: Subtracts displayed measurement from subsequent readings.

MENU: DC Measurement Delay, Default Delay On/Off, Local/Remote Sense, 50/60Hz, IEEE Address, Self Tests.

DATA ENTRY: Numeric keypad or detented rotary dial.

TRIGGER:

Input and Output: Set for any phase of SOURCE-DELAY-MEASURE sequence or trigger output at end of sweep.

Origin: Internal, External (including front panel MANUAL TRIGGER button), IEEE-488 bus (TALK, GET, "X").

MEMORY: Stores one full sweep (up to 1000 points) of source, delay, and measure values, elapsed times, and sweep parameters. Lithium battery backup.

INTERLOCK: Use with test fixture or external switch. Normally closed; open puts instrument in standby.

VOLTAGE

SOURCE V			MEASURE V		
RANGE (Max. Value)	STEP SIZE	ACCURACY (1 Year, 18°-28°C)	RESOLUTION 4-Digit	RESOLUTION 5-Digit	ACCURACY ¹ (1 Year, 18°-28°C)
±1.1000V ²	100 µV	±(0.033%+650 µV + [I _o /I _{FS}] × 450µV)	100 µV	10 µV	±(0.028% + 300µV + [I _o /I _{FS}] × 450µV)
±11.000V	1 mV	±(0.033%+ 2.4mV)	1 mV	100 µV	±(0.025%+ 1mV)
±110.00V	10 mV	±(0.033%+ 24mV)	10 mV	1 mV	±(0.025%+ 10mV)
±1100.0V ³	100 mV	±(0.04 %+240mV)	100 mV	10 mV	±(0.035%+100mV)

I_o = Output current

I_{FS} = Full scale on selected current range

¹ Specifications apply for 5-digit resolution. For 4-digit resolution add 100ppm of range.

² Assumes remote sense for I > 100µA.

³ 1100V range available on Model 237 only.

COMPLIANCE: Bipolar current limit set with single value.

Maximum: ±100mA (except ±10mA on 1100V range in Model 237).

Minimum: ±0.1% of range, except 0.5% of 1.1V range.

Accuracy, Step Size: Same as current source.

NOISE (p-p):	Range	0.1-10Hz
	110V-1100V	< 3ppm of range
	11 V	< 3ppm of range
	1.1 V	<10ppm of range

WIDEBAND NOISE: 0.1 to 20MHz, 8mV p-p typical.

OVERSHOOT: <0.01% (110V step, 10mA range).

SETTLING TIME: <500µsec. to 0.01% (110V step, 10mA range).

NMRR: >60dB at 50 or 60Hz (LINE CYCLE integration time selected).

CMRR: >120dB at DC, 50 or 60Hz (LINE CYCLE integration time selected).

INPUT IMPEDANCE (as a voltmeter): >10¹⁴Ω paralleled by <20pF.

CURRENT

SOURCE I			MEASURE I		
RANGE (Max. Value)	STEP SIZE	ACCURACY (1 Year, 18°-28°C)	RESOLUTION 4-Digit	RESOLUTION 5-Digit	ACCURACY ¹ (1 Year, 18°-28°C)
±1.0000 nA	100 fA	±(0.3 %+450 fA)	100 fA	10 fA	±(0.3 % +100 fA) ²
±10.000 nA	1 pA	±(0.3 % + 2 pA)	1 pA	100 fA	±(0.3 % + 1 pA)
±100.00 nA	10 pA	±(0.21%+ 20 pA)	10 pA	1 pA	±(0.21 % + 6 pA)
±1.0000 µA	100 pA	±(0.05%+200 pA)	100 pA	10 pA	±(0.04 % + 60 pA)
±10.000 µA	1 nA	±(0.05%+ 2 nA)	1 nA	100 pA	±(0.035%+700 pA)
±100.00 µA	10 nA	±(0.05%+ 20 nA)	10 nA	1 nA	±(0.035%+ 6 nA)
±1.0000 mA	100 nA	±(0.05%+200 nA)	100 nA	10 nA	±(0.035%+ 60 nA)
±10.000 mA	1 µA	±(0.05%+ 2 µA)	1 µA	100 nA	±(0.038%+600 nA)
±100.00 mA	10 µA	±(0.1 % + 20 µA)	10 µA	1 µA	±(0.1 % + 6 µA)

¹ Specifications apply for 5-digit resolution. For 4-digit resolution, all offset terms are 200ppm of range.

² Offset specification applies for 23°C ± 1°C with suppression. Temperature coefficient 50fA/°C.

COMPLIANCE: Bipolar voltage limit set with single value.

Maximum: ±1100V (except ±110V on 100mA range in Model 237).

Minimum: ±0.1% of selected current range.

Accuracy, Step Size: Same as voltage source.

NOISE (p-p of range): 0.1-10Hz: <3ppm (<20ppm on 1nA and 10nA ranges).

OVERSHOOT: <0.01% typical (10mA step, R_L = 10kΩ).

SETTLING TIME: <500µsec. to 0.01% (10mA step, R_L = 10kΩ).

OUTPUT R, C: >10¹⁴Ω paralleled by <20pF (on 1nA range).

VOLTAGE BURDEN (as an ammeter): <1mV.

IEEE-488 BUS IMPLEMENTATION

MULTILINE COMMANDS: DCL, LLO, SDC, GET, GTL, UNT, UNL, SPE, SPD.

UNILINE COMMANDS: IFC, REN, EOI, SRQ, ATN.

INTERFACE FUNCTIONS: SH1, AH1, T6, TE0, L4, LE0, SR1, RL1, PP0, DC1, DT1, C0, E1.

All front panel functions and setups are available over the IEEE-488 bus, in addition to Status, Service Request, Output Format, EOI, Trigger, and Terminator.

IEEE-488 address is set from front panel menu.

EXECUTION SPEED

MINIMUM SOURCE-DELAY-MEASURE CYCLE TIME: 1msec.

RESPONSE TO IEEE-488 COMMAND (as a source): 25msec.

MEASUREMENT RATE: 1msec. per point into internal buffer.

CONTINUOUS MEASUREMENT SPEED (source DC value over IEEE-488 bus): 110 readings per second.

TRIGGER LATENCY TIME: <2msec.

GENERAL

LOAD CAPACITANCE: Stable into 20,000pF typical.

REMOTE SENSE: Corrects for up to 2V drop in each output lead. Maximum 1k Ω per sense lead for rated accuracy. Residual output resistance (as a voltage source) is 0.5 Ω .

GUARD: Output Resistance: $\leq 12k\Omega$.

Maximum Output Current: $\pm 2mA$.

Offset Relative to Output HI: $\pm 2mV$ max.

ISOLATION (Output LO to chassis): Typically $>10^{10}\Omega$ in parallel with 500pF.

MAXIMUM COMMON MODE VOLTAGE: 200V.

CONNECTORS: Outputs: 3-lug triax.

Trigger Input/Output: BNC.

Interlock: 3-pin miniature DIN.

TEMPERATURE COEFFICIENT (0°–18°C & 28°–50°C):

$\pm(0.1 \times \text{applicable accuracy specification})/^\circ C$.

ENVIRONMENT:

Operating: 0°–50°C, 70% relative humidity up to 35°C. Linearly derate 3% RH/ $^\circ C$, 35°–50°C.

Storage: –25° to 65°C.

WARM-UP: One hour to rated accuracy.

COOLING: Internal fan forced air cooling.

POWER: 105–125 or 210–250V AC (external switch selectable), 90–110V and 180–220V version available. 100VA max.

DIMENSIONS, WEIGHT: 89mm high \times 435mm wide \times 448mm deep (3.5 in. \times 17.125 in. \times 17.625 in.). Net weight 9kg (19.75 lbs.).

ACCESSORIES SUPPLIED:

Model 7078-TRX-3: Triax to Triax Cable, 0.9m (3 ft.)

Model 236-ILC-3: Interlock Cable

ACCESSORIES AVAILABLE:

Model 8000-10: Equipment Rack for 3 SMUs (10 in.)

Model 8000-14: Equipment Rack for 4 SMUs (14 in.)

Table of Contents

SECTION 1 — Performance Verification

1.1	INTRODUCTION	1-1
1.2	ENVIRONMENTAL CONDITIONS	1-1
1.3	INITIAL CONDITIONS	1-1
1.4	REQUIRED TEST EQUIPMENT	1-1
1.5	VERIFICATIONS PROCEDURES	1-1
1.5.1	Equipment Characterization	1-3
1.5.2	Common Mode Verification	1-6
1.5.3	Voltage Source Verification	1-8
1.5.4	Voltage Measure Verification	1-9
1.5.5	Remote Sense Verification	1-11
1.5.6	Low Current (1nA to 10mA) Measure Ranges Verification	1-12
1.5.7	Low Current (1nA to 10mA) Source Ranges Verification	1-15
1.5.8	100mA Measure Range Verification	1-18
1.5.9	100mA Source Range Verification	1-20

SECTION 2 — Calibration

2.1	INTRODUCTION	2-1
2.2	RECOMMENDED CALIBRATION EQUIPMENT	2-1
2.3	ENVIRONMENTAL CONDITIONS	2-2
2.4	WARM-UP PERIOD	2-2
2.5	CAL LOCK	2-2
2.6	CALIBRATION PROCEDURES	2-2
2.6.1	Equipment Characterization	2-3
2.6.2	Voltage Calibration	2-6
2.6.3	100mA Range Calibration	2-9
2.6.4	Low Current Ranges Calibration (1nA – 10mA)	2-11
2.7	CALIBRATION ERRORS	2-13
2.8	CALIBRATION PROGRAM	2-16

SECTION 3 — Maintenance

3.1	INTRODUCTION	3-1
3.2	LINE FUSE REPLACEMENT	3-1
3.3	FAN FILTER CLEANING	3-1
3.4	BATTERY REPLACEMENT	3-2
3.5	HANDLING AND CLEANING PRECAUTIONS	3-4
3.6	DISASSEMBLY INSTRUCTIONS	3-4
3.7	SPECIAL HANDLING OF STATIC SENSITIVE DEVICES	3-11
3.8	TROUBLESHOOTING	3-11
3.8.1	Recommended Test Equipment	3-11

3.8.2	Diagnostics	3-11
3.8.3	Power Supply Checks	3-13
3.8.4	Analog Control Lines	3-14
3.8.5	Analog Switching	3-14
3.8.6	Digital and Display Checks	3-16

SECTION 4 — Principles of Operation

4.1	INTRODUCTION	4-1
4.2	ANALOG CIRCUITRY	4-2
4.2.1	V/I Control and Readback	4-2
4.2.2	Output Stage	4-4
4.2.3	V/I Feedback	4-6
4.2.4	Resonant Converter (Model 237)	4-8
4.3	A/D CONVERTER	4-8
4.4	DIGITAL CIRCUITRY	4-9
4.4.1	I/O Controller	4-9
4.4.2	Source/Measure Controller	4-10
4.4.3	Communications	4-10
4.4.4	Display Circuitry	4-10
4.5	POWER SUPPLY	4-11

SECTION 5 — Replaceable Parts

5.1	INTRODUCTION	5-1
5.2	PARTS LISTS	5-1
5.3	ORDERING INFORMATION	5-1
5.4	FACTORY SERVICE	5-1
5.5	SCHEMATIC DIAGRAMS AND COMPONENT LOCATION DRAWINGS	5-1

List of Illustrations

SECTION 1 — Performance Verification

Figure 1-1	Setup for Equipment Characterization	1-4
Figure 1-2	Setup for Common Mode Verification	1-7
Figure 1-3	Setup for Voltage Source Ranges Verification	1-9
Figure 1-4	Setup for Voltage Measure Ranges Verification	1-10
Figure 1-5	Setup for Remote Sense Verification	1-12
Figure 1-6	Setup for Low Current Measure Ranges Verification (1nA to 10mA)	1-13
Figure 1-7	Setup for Low Current Source Ranges Verification (1nA to 10mA)	1-16
Figure 1-8	Setup for 100mA Measure Range Verification	1-19
Figure 1-9	Setup for 100mA Source Range Verification	1-21

SECTION 2 — Calibration

Figure 2-1	Calibration Switch (Cal Lock)	2-2
Figure 2-2	Setup for Equipment Characterization	2-4
Figure 2-3	Setup for Volts Calibration	2-7
Figure 2-4	Setup for 100mA Range Calibration	2-10
Figure 2-5	Current Ranges Calibration (1nA to 10mA)	2-12
Figure 2-6	U1 Error Status Word	2-15
Figure 2-7	U7 Calibration Status Word	2-16

SECTION 3 — Maintenance

Figure 3-1	Line Voltage Switch and Line Fuse	3-1
Figure 3-2	Digital Board	3-3
Figure 3-3	Resonant Converter Board (Model 237)	3-5
Figure 3-4	Output Board	3-6
Figure 3-5	Analog Board (Shields Removed)	3-7
Figure 3-6	Model 237 Exploded View	3-9

SECTION 4 — Principles of Operation

Figure 4-1	Overall Block Diagram	4-1
Figure 4-2	Simplified Schematic of V/I Control and Readback	4-3
Figure 4-3	Model 236 Output Stage (Simplified Schematic Diagram)	4-5
Figure 4-4	Model 237 Output Stage (Simplified Schematic Diagram)	4-5
Figure 4-5	Simplified Schematic of V/I Feedback	4-6
Figure 4-6	Damping Relay Contact Bounce	4-7
Figure 4-7	Simplified Schematic of Resonant Converter	4-9

List of Tables

SECTION 1 — Performance Verification

Table 1-1	Required Test Equipment	1-2
Table 1-2	Specifications For Alternate Equipment	1-3
Table 1-3	Model 263 I-Source Characteristics	1-5
Table 1-4	Voltage Source Verification	1-8
Table 1-5	Voltage Measure Verification	1-11
Table 1-6	Allowable Reading Calculations for Low Current Measure Verification (1mA to 10mA)	1-13
Table 1-7	Low Current Measure Verification (1nA to 10mA)	1-14
Table 1-8	Allowable Reading Calculations for Low Current Source Verification (1mA to 10mA)	1-15
Table 1-9	Low Current Source Verification (1nA to 10mA)	1-17

SECTION 2 — Calibration

Table 2-1	Required Test Equipment	2-1
Table 2-2	Specifications For Alternate Equipment	2-2
Table 2-3	Model 263 I-Source Characterization	2-5
Table 2-4	Calibration Error Messages	2-14

SECTION 3 — Maintenance

Table 3-1	Line Fuse Selection	3-1
Table 3-2	Recommended Troubleshooting Equipment	3-11
Table 3-3	Power Supply Checks	3-13
Table 3-4	Analog Switching; Current Ranging	3-14
Table 3-5	Analog Switching; Volts Ranging	3-15
Table 3-6	Analog Switching; Feedback	3-15
Table 3-7	Analog Switching; Sensing	3-15
Table 3-8	Analog Switching; A/D Multiplexing	3-16
Table 3-9	Digital Circuitry Checks	3-17
Table 3-10	Display Circuitry Checks	3-18

SECTION 4 — Principles of Operation

Table 4-1	Volts Range Relays	4-8
-----------	------------------------------	-----

SECTION 1

Performance Verification

1.1 INTRODUCTION

The procedures outlined in this section may be used to verify that the instrument is operating within the limits stated in the specifications at the front of this manual. Performance verification may be performed when the instrument is first received to ensure that no damage or misadjustment has occurred during shipment. Verification may also be performed whenever there is question of instrument accuracy, or following calibration, if desired.

NOTE

If the instrument is still under warranty (less than 1 year from the date of shipment), and its performance falls outside the specified range, contact your Keithley representative or the factory to determine the correct course of action.

Before attempting any of the following procedures, make sure you are familiar with the controls and operation of the Model 236/237. Refer to the Model 236/237 Operator's Manual for complete information.

1.2 ENVIRONMENTAL CONDITIONS

All measurements should be made at 18-28°C (65-82°F) and at less than 70% humidity.

1.3 INITIAL CONDITIONS

WARNING

The Source Measure Unit is equipped with a 3-wire power cord that contains a separate

ground wire and is designed to be used with grounded outlets. When proper connections are made, instrument chassis is connected to power line ground. Failure to use a grounded outlet may result in injury or death due to electric shock.

The Model 236/237 must be turned on and allowed to warm up for at least one hour before beginning the verification procedures. If the instrument has been subject to extremes of temperature (outside the range specified in paragraph 1.2), additional time should be allowed for internal temperatures to reach normal operating temperature. Typically, it takes one additional hour to stabilize a unit that is 10°C (18°F) outside the specified temperature range.

1.4 RECOMMENDED TEST EQUIPMENT

Table 1-1 summarizes recommended equipment for the verification procedures. Alternate equipment may be used as long as the substitute equipment has specifications at least as good as those listed in Table 1-2. Note that equipment characterization (paragraph 1.5.1) is not required if using equipment that meets the specifications in Table 1-2.

The accuracy limits stated in the verification procedures are based only on Model 236/237 specifications, and they do not include test equipment tolerance. If a particular measurement falls slightly outside the allowed range, calculate new limits based both on instrument accuracy specifications and test equipment accuracy specifications, then repeat the test.

Table 1-1. Required Test Equipment

Manufacturer	Model	Description	Specifications
Keithley	263	5-1/2 digit Calibrator/ Source	2nA, 20nA ranges; $\pm(0.0625\% + 10 \text{ counts})$ 200nA range; $\pm(0.035\% + 10 \text{ counts})$
Keithley	193A	5-1/2 digit DMM	200mV, 2V ranges; $\pm(0.005\% + 2 \text{ counts})$ 20V-1000V ranges; $\pm(0.007\% + 1 \text{ count})$ 200 Ω -200k Ω ranges; $\pm(0.007\% + 2 \text{ counts})$
Keithley	617	4-1/2 digit Electrometer	2pA range; $\pm(1.6\% + 66 \text{ counts})$ 20pA range; $\pm(1.6\% + 7 \text{ counts})$ 200pA range; $\pm(1.6\% + 1 \text{ count})$ 2nA range; $\pm(0.25\% + 5 \text{ counts})$ 20nA range; $\pm(0.25\% + 1 \text{ count})$ 200nA range; $\pm(0.25\% + 1 \text{ count})$ 2 μ A range; $\pm(0.15\% + 4 \text{ counts})$ 20 μ A range; $\pm(0.15\% + 1 \text{ count})$
Keithley	8006	Test Fixture	—
Keithley	236-ILC-3	Interlock Cable	—
Fluke	343A	Dc Voltage Calibrator	10V-1000V ranges; $\pm 0.002\%$
Valhalla	2500E	Current Calibrator	300mA range; $\pm 0.025\%$
Keithley	R-185-10 R-249-100 R-263-1k R-263-100K	10 Ω Resistor 100 Ω Resistor 1k Ω Resistor 100k Ω Resistor	$\pm 0.1\%$, $\pm 10\text{ppm}/^\circ\text{C}$ $\pm 0.1\%$, $\pm 20\text{ppm}/^\circ\text{C}$ $\pm 0.1\%$, $\pm 10\text{ppm}/^\circ\text{C}$ $\pm 0.1\%$, $\pm 10\text{ppm}/^\circ\text{C}$
Keithley	7078-TRX	3-slot Triax cable (3 required)	—
Keithley	6172	2-slot male to 3-lug fe- male triax adapter (2 required)	—
Pomona	B-24	Banana plug cable (6 required)	—

1.5 VERIFICATIONS PROCEDURES

The following paragraphs contain the detailed procedures for verifying the one year accuracy specifications of the Model 236/237 using the equipment listed in Table 1-1. The allowable reading limits in these procedures include error that could be contributed by this equipment.

These procedures are intended for use only by qualified personnel using accurate and reliable test equipment. If

the instrument is out of specifications and not under warranty, refer to the calibration section of this manual.

WARNING

Lethal voltages (up to 1000V for the Model 237) will be connected to the Model 8006 test fixture. To avoid a possible shock hazard, the safety interlock circuit must be connected to the Model 236/237.

Connect the test fixture  screw to safety earth ground using #18 AWG wire minimum before use. Turn off all power before connecting or disconnecting wires or cables.

Also, keep in mind that GUARD is always enabled. Thus, a lethal voltage on OUTPUT HI is also present on the two GUARD terminals of the Model 236/237.

Table 1-2. Specifications For Alternate Equipment

Instrument Type	Required Specifications
DMM	Same as Keithley 193A (see Table 1-1)
Source dc Current	0.9nA, 9nA, 90nA, Same as Keithley 263 (see Table 1-1) 0.9μA; ±180ppm 9μA, 90μA, 900μA, 9mA; ±170ppm
Measure dc Current	250ppm rdg ±500nA

1.5.1 Equipment Characterization

In order to verify the 1μA, 10μA, 100μA and 1mA source and measure ranges of the Model 236/237, the 0.9μA, 9μA, 90μA, 0.9mA and 9mA outputs of the Model 263 are characterized. For the 10mA source and measure range, a 10Ω resistor is characterized. Perform the following steps for characterization:

1. Connect the Model 263 source, Model 193A DMM and Model 8006 test fixture as shown in Figure 1-1. Install the 100kΩ resistor (in Table 1-1) in the AXIAL KELVIN CLIPS test socket of the test fixture.
2. Configure the source and DMM as follows:

Model 263 — Amps function, +0.90000μA on 2μA range, GUARD enabled and output in standby.

Model 193A — Ohms function on the 200kΩ range.

3. Zero the Model 193A as follows:
 - A. At the SENSE 1 (HI) terminal of the test socket, disconnect the jumper whose other end is connected to BINDING POST 2 on the Signal Panel.
 - B. Connect that jumper to the SENSE 2 (LO) terminal of the test socket. This shorts the Ohms Sense input of the Model 193A at the test socket.
 - C. On the Model 193A, enable ZERO to cancel test lead resistance.
 - D. Relocate the jumper back to the SENSE 1 terminal of the test socket. Make sure the connections at the Component Test Module are correct as shown in Figure 1-1.
4. In the space provided below, use a pencil to record the actual value of the 100kΩ resistor from the display of the Model 193A.

$$R_{100k\Omega} = \text{_____} \text{ k}\Omega$$

5. Set the Model 193A to the DCV function and the 200mV range, and disable ZERO.
6. To cancel any offset, zero the Model 193A by shorting its input (VOLTS HI to LO) and enabling ZERO.
7. Remove the short from the input of the Model 193A and place the Model 263 in operate to source +0.90000μA to the 100kΩ resistor
8. In the space below, use a pencil to record the voltage drop across the resistor from the display of the Model 193A.

$$V_{100k\Omega} = \text{_____} \text{ mV}$$

9. Calculate (to 5-1/2 digits) the current through the 100kΩ resistor as follows:

$$I_{0.9\mu A} = \frac{V_{100k\Omega}}{R_{100k\Omega}} = \text{_____} \mu A$$

$I_{0.9\mu A}$ is the characterized current for the 2μA range of the Model 263. It is used to check the 1μA measurement range of the Model 236/237. Using a pencil, record the calculated value of $I_{0.9\mu A}$ in Entry 1 of Table 1-3.

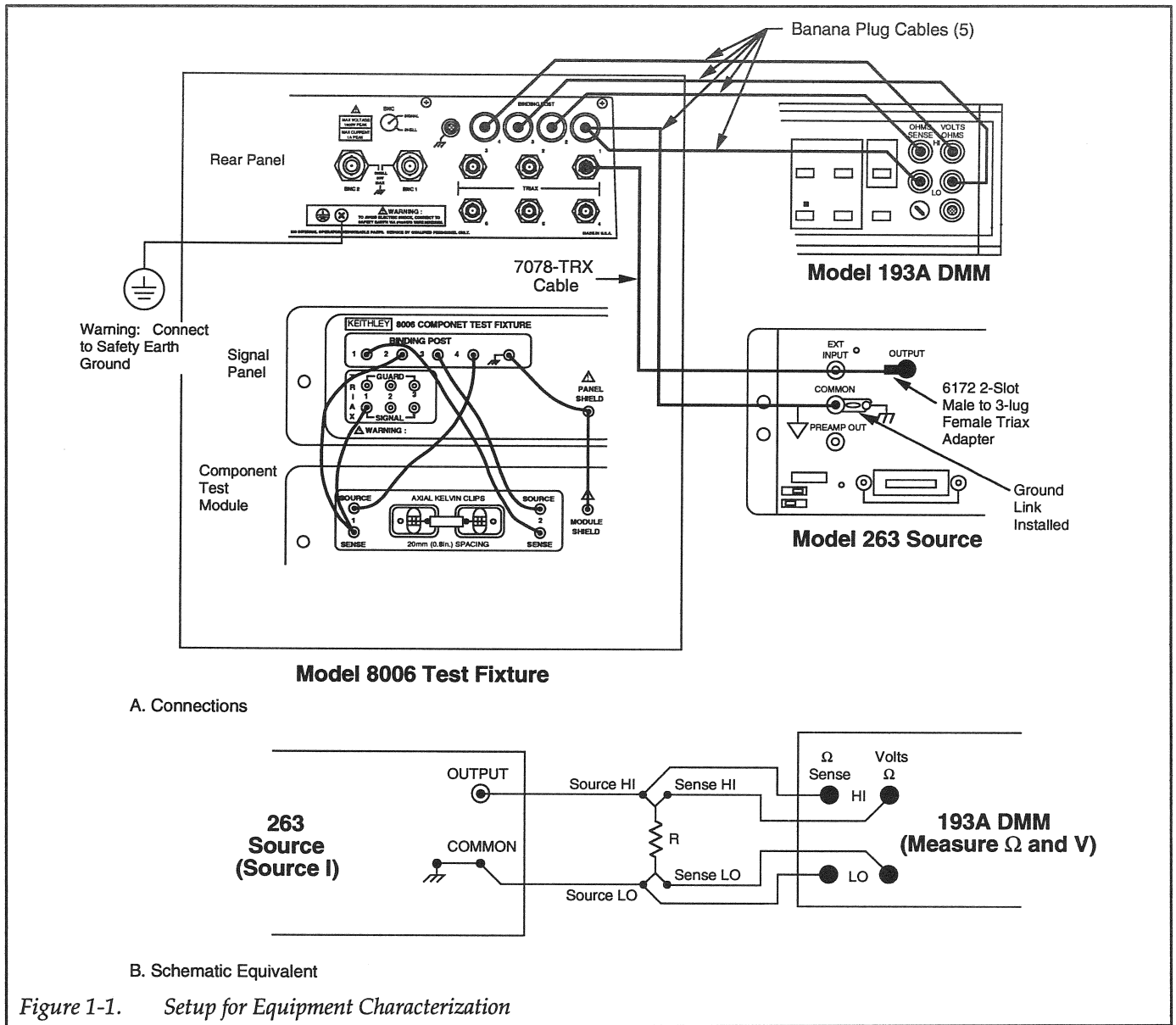

Figure 1-1. Setup for Equipment Characterization

Table 1-3. Model 263 I-Source Characteristics

Entry	263 I-Source		Characterized I-Source Value	I-Source Value Limits*
	Range	Programmed Value		
1	2μA	0.90000μA	$I_{0.9\mu A} = \underline{\hspace{2cm}}$	0.9μA ±450pA
2	20μA	9.0000μA	$I_{9\mu A} = \underline{\hspace{2cm}}$	9μA ±4.3nA
3	200μA	90.000μA	$I_{90\mu A} = \underline{\hspace{2cm}}$	90μA ±45nA
4	2mA	0.90000mA	$I_{0.9mA} = \underline{\hspace{2cm}}$	0.9mA ±430nA
5	20mA	9.0000mA	$I_{9mA} = \underline{\hspace{2cm}}$	9mA ±5.4μA

*The characterized I-source values should be within the listed limits. These limits are based on 90-day specifications of the Models 263 and 193A. A characterized value that does not fall within these limits indicates a calculation error, or that the Model 263 and/or Model 193A is out of specification.

10. Place the Model 263 in standby.
11. Set the Model 193A to the 2V range.
12. Set the Model 263 to source 9.0000μA on the 20μA range and enable OPERATE.
13. As performed in steps 8 and 9, measure the voltage across the 100kΩ resistor and calculate the current.

$$V_{100k\Omega} = \underline{\hspace{2cm}} \text{ V}$$

$$I_{9\mu A} = \frac{V_{100k\Omega}}{R_{100k\Omega}} = \underline{\hspace{2cm}} \mu A$$

$I_{9\mu A}$ is the characterized current for the 20μA range of the Model 263. It is used to check the 10μA measurement range of the Model 236/237. Using a pencil, record the calculated value of $I_{9\mu A}$ in Entry 2 of Table 1-3.

14. Place the Model 263 in standby.
15. In the test fixture, remove the 100kΩ resistor and install the 1kΩ resistor (R-263-1k).
16. On the Model 193A, select the Ohms function, 2kΩ range and disable ZERO.
17. Repeat step 3 to zero the Model 193A.
18. Measure and record the value of the 1kΩ resistor.

$$R_{1k\Omega} = \underline{\hspace{2cm}} \text{ k}\Omega$$

19. Set the Model 193A to DCV and the 200mV range, and disable ZERO.
20. To cancel any offset, zero the Model 193A by shorting its input (VOLTS HI to LO) and enabling ZERO.
21. Remove the short from the input of the Model 193A and set the Model 263 to source 90.000μA on the 200μA range and enable OPERATE.
22. Record the voltage measurement from the Model 193A and calculate the current.

$$V_{1k\Omega} = \underline{\hspace{2cm}} \text{ mV}$$

$$I_{90\mu A} = \frac{V_{1k\Omega}}{R_{1k\Omega}} = \underline{\hspace{2cm}} \mu A$$

$I_{90\mu A}$ is the characterized current for the 200μA range of the Model 263. It is used to check the 100μA measurement range of the Model 236/237. Using a pencil, record the calculated value of $I_{90\mu A}$ in Entry 3 of Table 1-3.

23. Place the Model 263 in standby.
24. Set the Model 193A to the 2V range.
25. Set the Model 263 to source 0.90000mA on the 2mA range, and enable OPERATE.
26. Record the voltage measurement from the Model 193A and calculate the current.

$I_{0.9mA}$ is the characterized current for the 2mA range of the Model 263. It is used to check the 1mA measurement range of the Model 236/237. Using a pencil,

$$V_{1k\Omega} = \underline{\hspace{2cm}} \text{ V}$$

$$I_{0.9mA} = \frac{V_{100\Omega}}{R_{100\Omega}} = \underline{\hspace{2cm}} \text{ mA}$$

record the calculated value of $I_{0.9mA}$ in Entry 4 of Table 1-3.

27. Place the Model 263 in standby.
28. In the test fixture, remove the 1k Ω resistor and install the 100 Ω resistor (R-249-100).
29. On the Model 193A, select the Ohms function, 200 Ω range and disable ZERO.
30. Repeat step 3 to zero the Model 193A.
31. Measure and record the value of the 100 Ω resistor.

$$R_{100\Omega} = \underline{\hspace{2cm}} \Omega$$

32. Set the Model 193A to DCV and the 2V range, and disable ZERO.
33. To cancel any offset, zero the Model 193A by shorting its input (VOLTS HI to LO) and enabling ZERO.
34. Remove the short from the input of the Model 193A and set the Model 263 to source 9.0000mA on the 20mA range and enable OPERATE.
35. Record the voltage measurement from the Model 193A and calculate the current.

$$V_{100\Omega} = \underline{\hspace{2cm}} \text{ V}$$

$$I_{9mA} = \frac{V_{100\Omega}}{R_{100\Omega}} = \underline{\hspace{2cm}} \text{ mA}$$

I_{9mA} is the characterized current for the 20mA range of the Model 263. It is used to check the 10mA measurement range of the Model 236/237. Using a pencil, record the calculated value of I_{9mA} in Entry 5 of Table 1-3.

36. Place the Model 263 in standby.
37. In the test fixture, remove the 100 Ω resistor and install the 10 Ω resistor (R-185-10).
38. On the Model 193A DMM, disable ZERO and select the 200mV DC range.
39. While in standby, set the Model 263 to +9.0000mA on the 20mA range.
40. Zero the Model 193A by shorting its input (VOLTS HI to LO) and enabling ZERO.

41. Remove the short from the input of the Model 193A and place the Model 263 in operate.
42. Record the voltage measurement from the Model 193A and then place the Model 263 in standby.

$$V_{10\Omega} = \underline{\hspace{2cm}} \text{ mV}$$

43. Calculate the actual resistance of the 10 Ω resistor as follows:

$$R_{10\Omega} = \frac{V_{10\Omega}}{I_{9mA}} = \underline{\hspace{2cm}} \Omega$$

where; I_{9mA} is obtained from Table 1-3.

$R_{10\Omega}$ is used to verify the 100mA source and measure range of the Model 236/237.

1.5.2 Common Mode Verification

Set up the equipment as shown in Figure 1-2 and perform the following steps for common mode verification.

1. While in standby, program the Model 236/237 as follows; \int TIME at LINECYCLE PERIOD, source at +1.0000 μ A, and compliance at 1V on the 1.1V range.
2. Place the Model 236/237 in OPERATE and, using a pencil, record the voltage measurement in the space provided below.

$$V_{+1\mu A} = \underline{\hspace{2cm}} \text{ V}$$

3. From the keypad, change the source value to -1.0000 μ A and record that measurement.

$$V_{-1\mu A} = \underline{\hspace{2cm}} \text{ V}$$

4. Subtract the two voltage measurements from each other. Verify that the absolute value of the result is <150 μ V.

$$| V_{+1\mu A} - V_{-1\mu A} | < 150\mu V$$

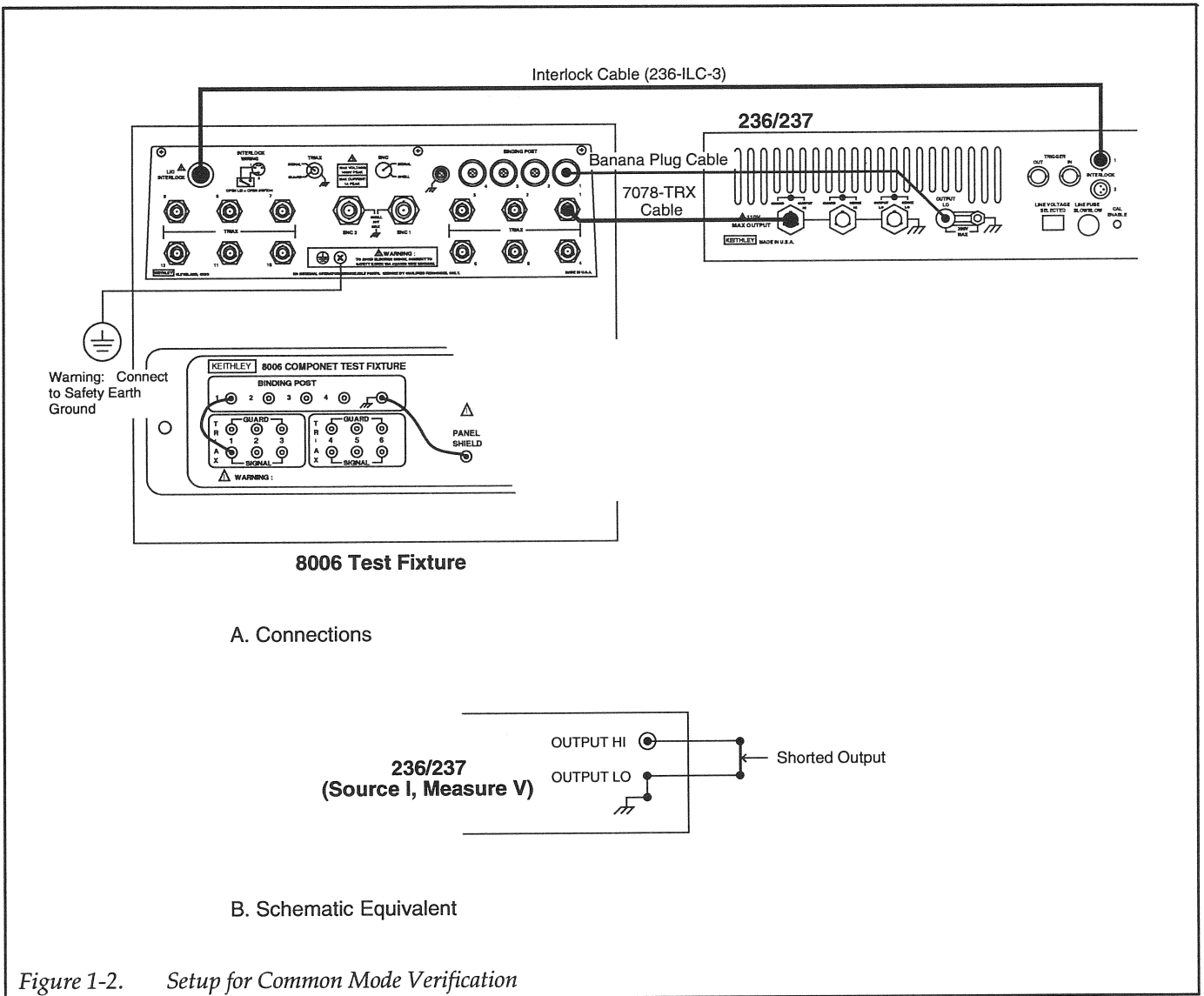

Figure 1-2. Setup for Common Mode Verification

1.5.3 Voltage Source Verification

Set up the equipment as shown in Figure 1-3 and perform the following steps to verify the voltage source.

WARNING

The following procedure uses hazardous voltages (1000V for the Model 237) that could cause injury or death. Exercise extreme caution when encountering these lethal voltage levels.

1. Set the Model 193A to measure DCV on the 200mV range.
2. While in standby, set the Model 236 to source 0V on the 1.1V range and set compliance to 10mA.
3. Temporarily disconnect the banana cable from BINDING POST 2 at the rear panel panel of the test fixture and connect it to VOLTS LO of the Model 193A. This will short the input of the Model 193A DMM.
4. On the Model 193A, press ZERO to cancel any measurement offsets.
5. Re-connect the banana cable to BINDING POST 2 of the test fixture.
6. Place the Model 236/237 in operate and verify that the reading on the DMM is within the limits shown in the first entry of Table 1-4. Use the filter if the reading is noisy.
7. Press the SELECT ◀ button to select the 11V range and verify that the DMM reading is within the allowable limits in Table 1-4.
8. Using Table 1-4 as a guide, repeat step 7 to check the 0V output on the 110V and 1100V ranges.
9. From the keypad, program the Model 236 to source +1V on the 1.1V range and verify that reading on the 193A DMM is within the allowable limits.
10. Repeat step 9 for a source value of -1V.
11. Using Table 1-4 as a guide, check source values of ±10V, ±100V and for the Model 237, ±1000V.
12. Program the Model 236/237 to 0V and place it in standby.

Table 1-4. Voltage Source Verification

236/237 Source Value*	236/237 Source Range	193A Range	Allowable Reading on Model 193A (18°C to 28°C)
0V	1.1V	200mV	-0.650mV to +0.650mV
0V	11V	200mV	-2.400mV to +2.400mV
0V	110V	200mV	-24.000mV to +24.000mV
0V	1100V	2V	-0.240V to +0.240V
+1V	1.1V	2V	+0.99902V to +1.00098V
-1V	1.1V	2V	-0.99902V to -1.00098V
+10V	11V	20V	+9.9943V to +10.0057V
-10V	11V	20V	-9.9943V to -10.0057V
+100V	110V	200V	+99.943V to +100.057V
-100V	110V	200V	-99.943V to -100.057V
+1000V	1100V	1000V	+999.36V to +1000.64V
-1000V	1100V	1000V	-999.36V to -1000.64V

*Current compliance is set to 10mA.

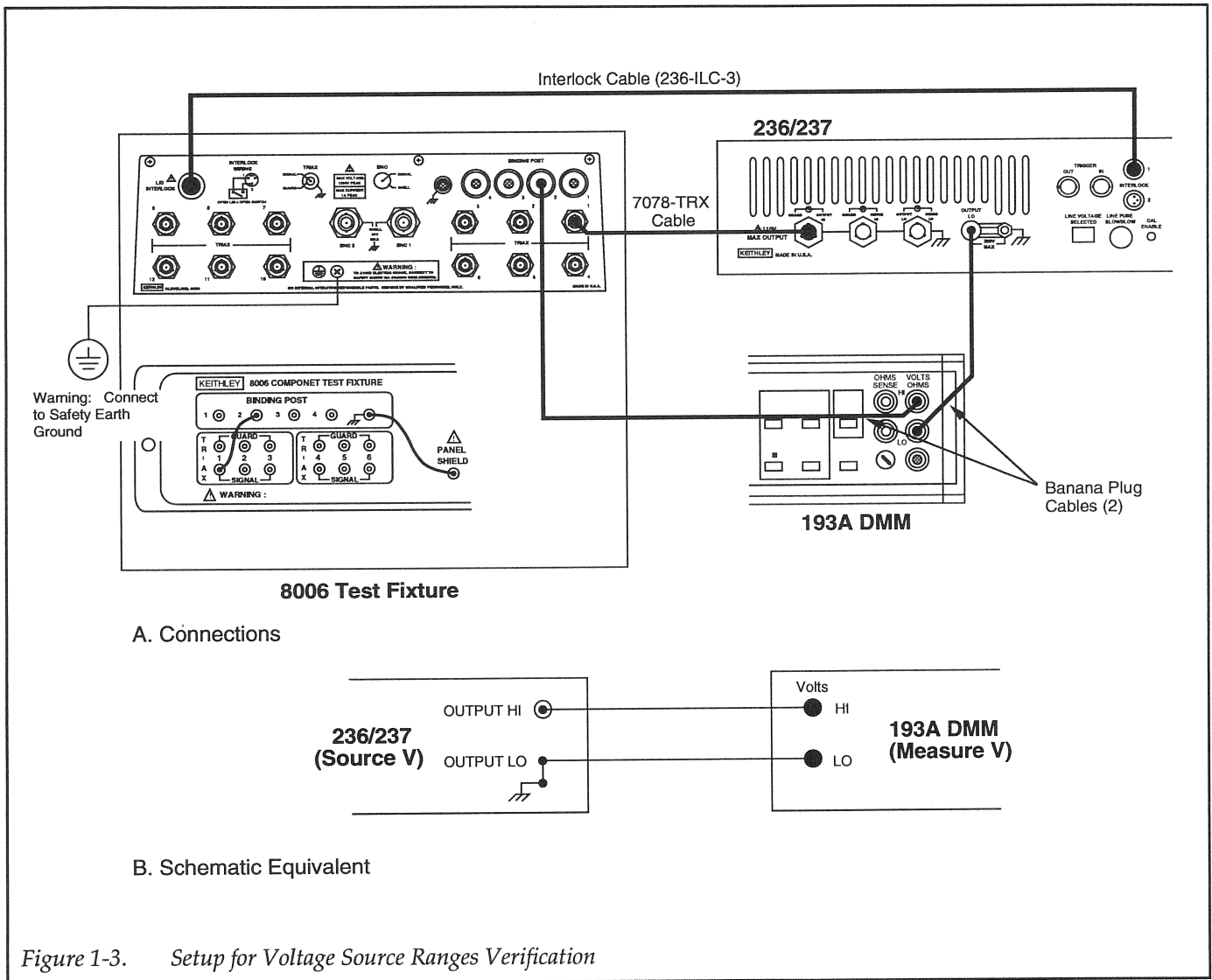

Figure 1-3. Setup for Voltage Source Ranges Verification

1.5.4 Voltage Measure Verification

Set up the equipment shown in Figure 1-4 and perform the following steps to verify voltage measurement:

WARNING

The following procedure uses hazardous voltages (1000V for the Model 237) that could cause injury or death. Exercise extreme caution when encountering these lethal voltage levels.

1. While in standby, configure the Model 236/237 to measure volts by setting it to source 0nA on the 1nA current source range.
2. While in standby, set the Model 343A calibrator to output 0V on the 10V range.
3. On the Model 236/237, set voltage compliance to 1.1V on the 1.1V measurement range.
4. Place the calibrator and the Model 236/237 in operate.
5. Verify that the measured voltage reading on the Model 236/237 is within the allowable limits listed in the first entry of Table 1-5.
6. On the Model 236/237, change the compliance limit to 11V on the 11V measurement range and verify that the voltage reading is within the limits in the table.
7. Using Table 1-5 as a guide, repeat step 6 to measure 0V on the 110V and 1100V measurement ranges.
8. Set the calibrator to output +1V on the 10V range, and set the Model 236/237 for a compliance limit of 1.1V on the 1.1V measurement range. Verify that the

SECTION 1
Performance Verification

- voltage reading on the Model 236/237 is within the allowable limits in the table.
9. Repeat step 8 using a calibrator output of $-1V$.
 10. Using Table 1-5 as a guide, measure calibrator outputs of $\pm 10V$, $\pm 100V$ and $\pm 1000V$ (Model 237 only).
 11. Place the Model 236/237 in standby.

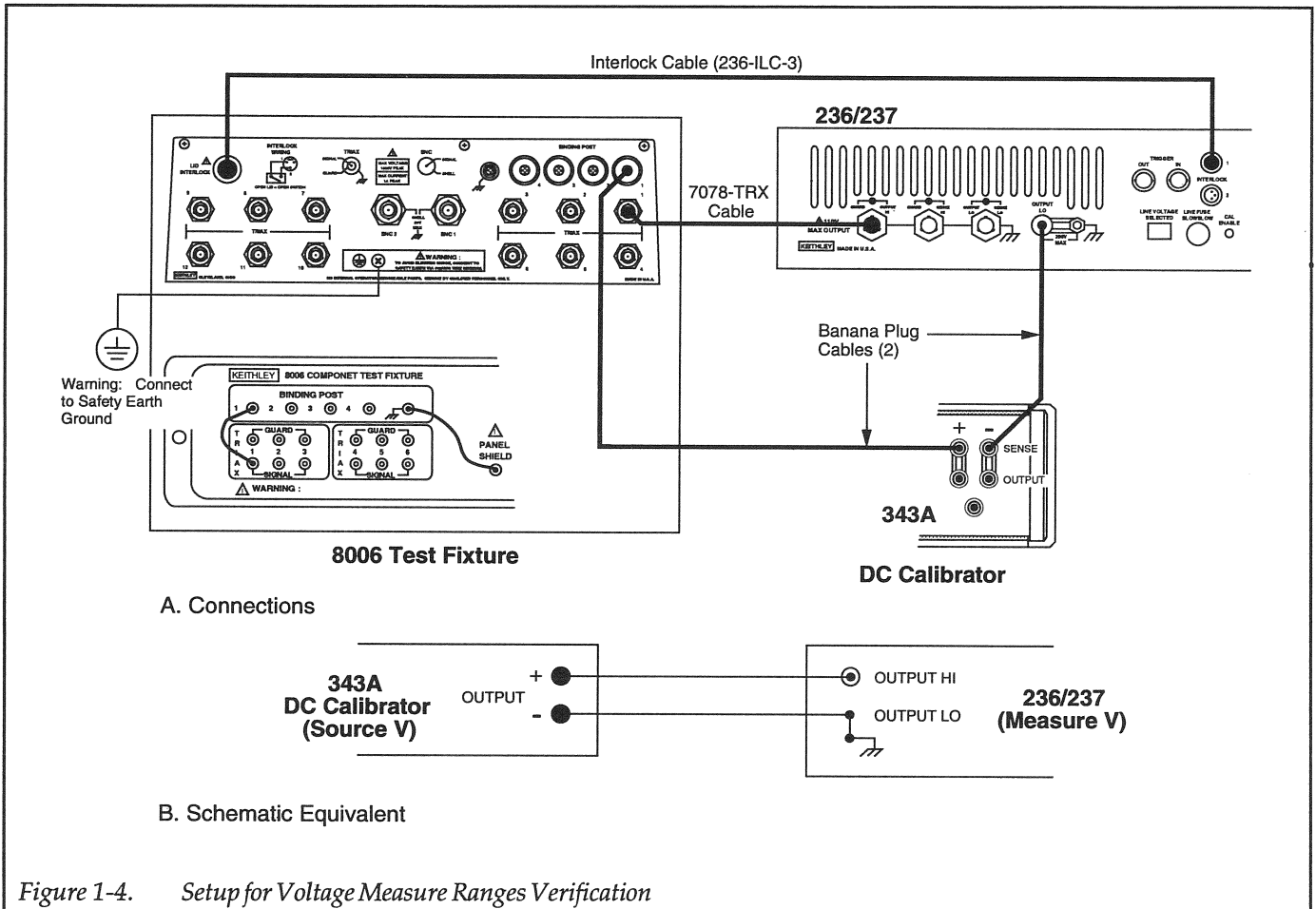

Figure 1-4. Setup for Voltage Measure Ranges Verification

Table 1-5. Voltage Measure Verification

343A Range	343A Output	236/237 Compliance Limit & Measure Range*	Allowable Reading (18°C to 28°C)
10V	0V	1.1V	-0.00030V to +0.00030V
10V	0V	11V	-00.0010V to +00.0010V
10V	0V	110V	-000.010V to +000.010V
10V	0V	1100V	-0000.10V to +0000.10V
10V	+1V	1.1V	+0.99942V to +1.00058V
10V	-1V	1.1V	-0.99942V to -1.00058V
10V	+10V	11V	+9.9965V to +10.0035V
10V	-10V	11V	-9.9965V to -10.0035V
100V	+100V	110V	+99.965V to +100.035V
100V	-100V	110V	-99.965V to -100.035V
1000V	+1000V	1100V	+999.55V to +1000.45V
1000V	-1000V	1100V	-999.55V to -1000.45V

*236/237 set to source 0nA on 1nA source range.

1.5.5 Remote Sense Verification

Set up the equipment as shown in Figure 1-5. The 1kΩ resistor (R-263-1k) is installed in the Kelvin test socket. Perform the following steps to verify remote sense accuracy:

WARNING

When a Model 236/237 is programmed for remote sensing, hazardous voltage may be present on the SENSE and OUTPUT terminals when the unit is in operate regardless of the programmed voltage or current. To avoid a possible shock hazard, always turn off all power before connecting or disconnecting cables to the Source Measure Unit or the associated test fixture.

1. While in standby, place the Model 236/237 in remote sense and set it to source 10V with a compliance limit of 10mA on the 10mA measurement range. Place the Model 236/237 in standby.
2. Set the Model 193A DMM to DCV and select the 20V range.
3. Temporarily disconnect the banana cable from VOLTS HI of the DMM at the rear panel of the test fixture (BINDING POST 1), and connect it to VOLTS LO of the DMM. This shorts the input of the Model 193A DMM.
4. On the Model 193A DMM, enable ZERO to cancel any offsets.
5. Re-connect the banana cable to BINDING POST 1 of the test fixture.
6. Place the Model 236/237 in operate and verify that the reading on the DMM is within the following allowable limit; 9.99500 V to 10.00500V.
7. Place the Model 236/237 in standby and local sense.

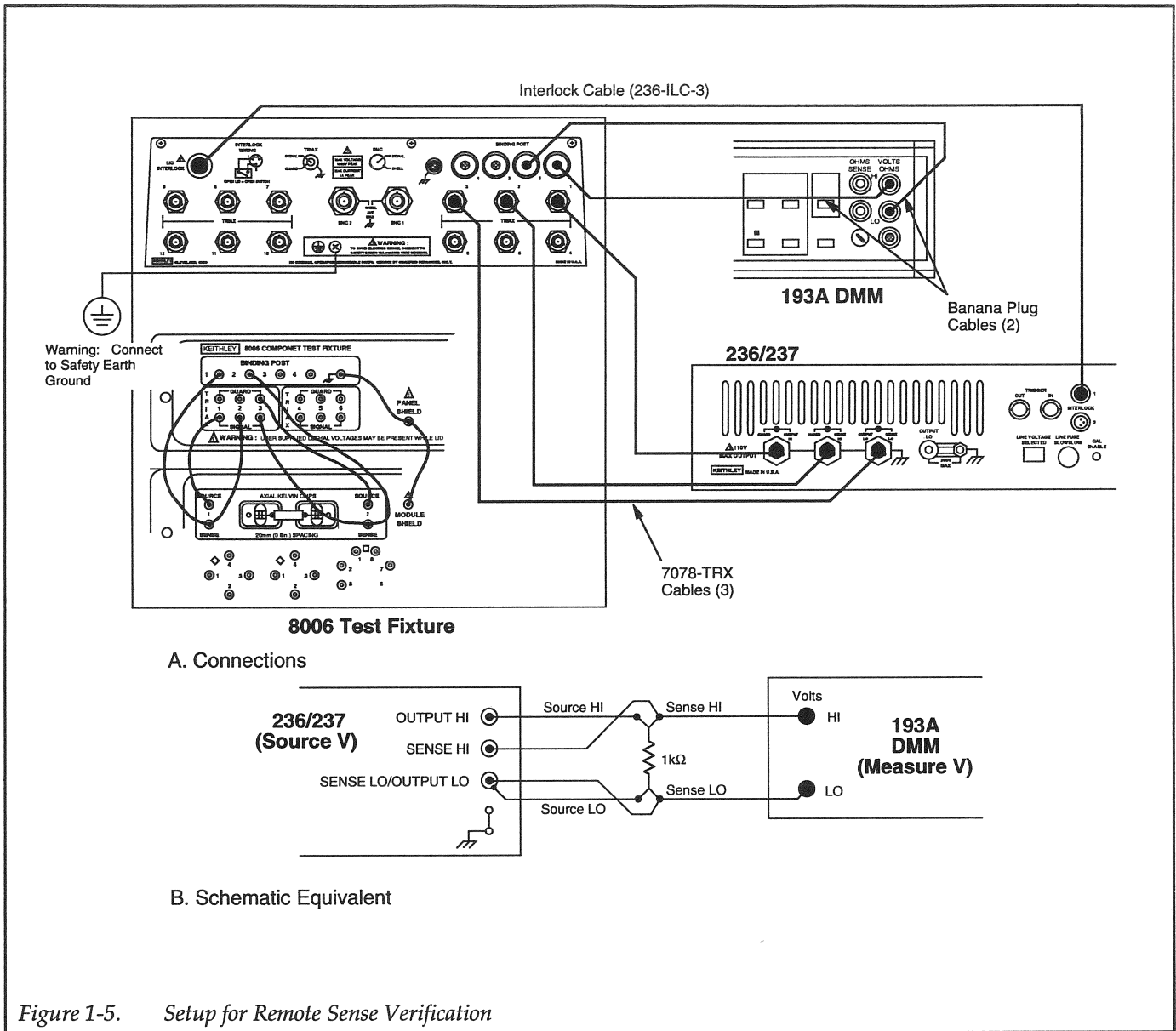

Figure 1-5. Setup for Remote Sense Verification

1.5.6 Low Current (1nA to 10mA) Measure Ranges Verification

Set up the equipment as shown in Figure 1-6 and perform the following steps to verify the 1nA to 10mA measure ranges:

1. Use Table 1-6 to calculate the allowable readings for the 1 μ A through 10mA ranges. The values for $I_{0.9\mu A}$, $I_{9\mu A}$, $I_{90\mu A}$, $I_{0.9mA}$ and I_{9mA} were previously calculated and recorded in Table 1-3. After calculating these readings, transfer them to Table 1-7.
2. While in standby, configure the Model 236/327 to measure current by setting it to source 0V on the 1.1V source range.
3. While in standby, set the Model 263 to the 2nA range and enable GUARD.
4. Set the compliance limit of the Model 236/237 to 1nA on the 1nA measurement range and enable OPERATE. Verify that the current measurement on the Model 236 is within the allowable limits listed in the first entry of Table 1-7.
5. On the Model 236/237, change the compliance limit to 10nA on the 10nA measurement range. Verify that the reading on this measurement range is within the limits specified in the table.
6. Using Table 1-7, check the rest of the Model 236 current ranges with the output of the Model 263 in standby.

7. Set the Model 263 to output +0.90000nA on the 2nA range, and set the Model 236/237 compliance limit to 1nA on the 1nA measurement range.
8. Verify that the reading is within the limits specified in the table.
9. On the Model 263, change the output to negative polarity and verify that the reading is within the limits specified in the table.
10. Using Table 1-7 as a guide, check the 10nA through 10mA measurement ranges of the Model 236/237.
11. Place the the Model 263 in standby.

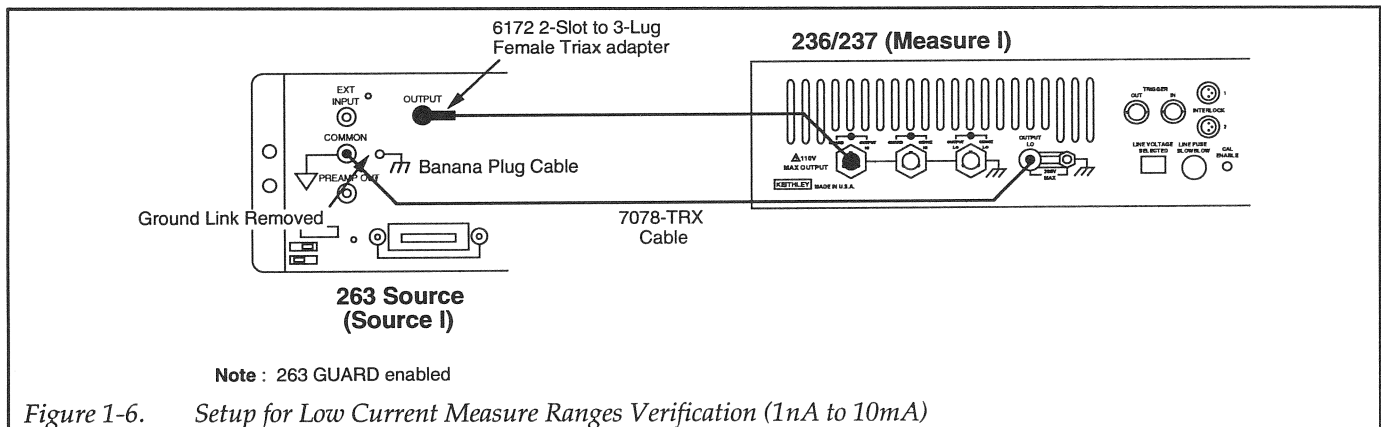

Table 1-6. Allowable Reading Calculations for Low Current Measure Verification (1µA to 10mA)

236/237 Measure Range	Reading Calculations*	Allowable Reading**		Typical Limits***
		Lower Limit	Upper Limit	
1µA	+I _{0.9µA} ± [(0.0004) I _{0.9µA} + 60pA] = -I _{0.9µA} ± [(0.0004) I _{0.9µA} + 60pA] =	+ µA - µA	+ µA - µA	+0.90000µA ±870pA -0.90000µA ±870pA
10µA	+I _{9µA} ± [(0.00035) I _{9µA} + 700pA] = -I _{9µA} ± [(0.00035) I _{9µA} + 700pA] =	+ µA - µA	+ µA - µA	+9.0000µA ±8nA -9.0000µA ±8nA
100µA	+I _{90µA} ± [(0.00035) I _{90µA} + 6nA] = -I _{90µA} ± [(0.00035) I _{90µA} + 6nA] =	+ µA - µA	+ µA - µA	+90.000µA ±83nA -90.000µA ±83nA
1mA	+I _{0.9mA} ± [(0.00035) I _{0.9mA} + 60nA] = -I _{0.9mA} ± [(0.00035) I _{0.9mA} + 60nA] =	+ mA - mA	+ mA - mA	+0.90000mA ±800nA -0.90000mA ±800nA
10mA	+I _{9mA} ± [(0.00038) I _{9mA} + 600nA] = -I _{9mA} ± [(0.00038) I _{9mA} + 600nA] =	+ mA - mA	+ mA - mA	+9.0000mA ±9.4µA -9.0000mA ±9.4µA

* I_{0.9µA}, I_{9µA}, I_{90µA}, I_{0.9mA} and I_{9mA} are obtained from Table 1-3.
 ** Allowable reading limits are to be transferred to Table 1-7.
 *** The calculated allowable readings should be within the listed typical limits. These limits are based on the 90-day specifications of the Model 263 and 193A. A calculated allowable reading that does not fall within these limits indicates a calculation error, or that the Model 263 and/or Model 193A is out of specification.

Table 1-7. Low Current Measure Verification (1nA to 10mA)

263 Range	263 Output	236/237 Compliance Limit & Measure Range*	Allowable Readings** (18°C to 28°C)
2nA	Standby	1nA	-0.00010nA to +0.00010nA
2nA	Standby	10nA	-00.0010nA to +00.0010nA
2nA	Standby	100nA	-000.006nA to +000.006nA
2nA	Standby	1µA	-0.00006µA to +0.00006µA
2nA	Standby	10µA	-00.0007µA to +00.0007µA
2nA	Standby	100µA	-000.006µA to +000.006µA
2nA	Standby	1mA	-0.00006mA to +0.00006mA
2nA	Standby	10mA	-00.0006mA to +00.0006mA
2nA	+0.90000nA	1nA	-0.89720nA to +0.90280nA
2nA	-0.90000nA	1nA	+0.89720nA to -0.90280nA
20nA	+9.0000nA	10nA	-8.9720nA to -9.0280nA
20nA	-9.0000nA	10nA	+8.9720nA to +9.0280nA
200nA	+90.000nA	100nA	-89.805nA to -90.195nA
200nA	-90.000nA	100nA	+89.805nA to +90.195nA
2µA	+0.90000µA	1µA	- _____ to - _____
2µA	-0.90000µA	1µA	+ _____ to + _____
20µA	+9.0000µA	10µA	- _____ to - _____
20µA	-9.0000µA	10µA	+ _____ to + _____
200µA	+90.000µA	100µA	- _____ to - _____
200µA	-90.000µA	100µA	+ _____ to + _____
2mA	+0.90000mA	1mA	- _____ to - _____
2mA	-0.90000mA	1mA	+ _____ to + _____
20mA	+9.0000mA	10mA	- _____ to - _____
20mA	-9.0000mA	10mA	+ _____ to + _____

*236/237 set to source 0V on the 1.1V source range.

**Allowable readings for the 1µA thru 10mA ranges are calculated in Table 1-6.

1.5.7 Low Current (1nA to 10mA) Source Ranges Verification

Set up the equipment as shown in Figure 1-7 and perform the following steps to verify the 1nA to 10mA source ranges:

1. Use Table 1-8 to calculate the allowable readings for the 1 μ A through 10mA ranges. The values for $I_{0.9\mu A}$, $I_{9\mu A}$, $I_{90\mu A}$, $I_{0.9mA}$ and I_{9mA} were previously calculated and recorded in Table 1-3. After calculating the allowable readings, transfer them to Table 1-9.
2. While in standby, configure the Model 236/237 to source 0nA on the 1nA source range with a compliance limit of 1.1V on the 1.1V measurement range.
3. While in standby, configure the Model 263 to source 0nA on the 2nA range.
4. With ZERO CHECK enabled, zero correct the Model 617 on the 2pA range.
5. On the Model 617, disable ZERO CHECK and place the Model 236/237 in operate. Verify that the reading on the Model 617 is within the limits specified in the first entry of Table 1-9.
6. Set the Model 617 to the 20pA range, and set the Model 236 to source 0nA on the 10nA range. Verify that the reading on the Model 617 is within the limits specified in the second entry of Table 1-9.
7. Using Table 1-9 as a guide, set the Model 236/237 to source zero on the 100nA through 10mA ranges and check that the subsequent readings are within the listed limits.
8. Place the Model 617 in zero check and select the 20pA range.
9. Place the Model 236/237 in standby and program it source -0.9nA on the 1nA source range.
10. While still in standby, set the Model 263 to source +0.9nA on the 2nA range.
11. Place both the Models 236/237 and 263 in operate, and disable ZERO CHECK on the Model 617. Verify that the reading on the Model 617 is within the limits specified in the table.
12. Place the Model 617 in zero check, and the Models 263 and 236/237 in standby.
13. On both the Models 263 and 236/237, reverse the polarity of the sources. That is, set the Model 236/237 to +0.9nA and the Model 263 to -0.9nA.
14. Place the Models 236/237 and 263 in operate, and disable zero check on the Model 617. Verify that the reading on the Model 617 is still within the limits specified in the table.
15. Using Table 1-9 as a guide, repeat the basic procedure in steps 8 through 14 to check the 10nA through 10mA source ranges. Note that for the 1 μ A through 10mA ranges, the source values for the Model 236/237 are taken from Table 1-3.
16. Place the Model 617 in zero check, and the Models 263 and 236/237 in standby.

Table 1-8. Allowable Reading Calculations for Low Current Source Verification (1 μ A to 10mA)

236/237 Source Range	Reading Calculations*	Allowable Reading**		Typical Limits***
		Lower Limit	Upper Limit	
1 μ A	$\pm [(0.0005) I_{0.9\mu A} + 200pA] =$	- nA	+ nA	$\pm 0.6500nA$
10 μ A	$\pm [(0.00050) I_{9\mu A} + 2.00nA] =$	- nA	+ nA	$\pm 6.500nA$
100 μ A	$\pm [(0.00050) I_{90\mu A} + 20.00nA] =$	- nA	+ nA	$\pm 65.00nA$
1mA	$\pm [(0.00050) I_{0.9mA} + 200.0nA] =$	- μ A	+ μ A	$\pm 0.6500\mu A$
10mA	$\pm [(0.0005) I_{9mA} + 2.00\mu A] =$	- μ A	+ μ A	$\pm 6.500\mu A$

* $I_{0.9\mu A}$, $I_{9\mu A}$, $I_{90\mu A}$, $I_{0.9mA}$ and I_{9mA} are obtained from Table 1-3.

** Allowable reading limits are to be transferred to Table 1-9.

*** The calculated allowable readings should be within the listed typical limits. These limits are based on the 90-day specifications of the Model 263 and 193A. A calculated allowable reading that does not fall within these limits indicates a calculation error, or that the Model 263 and/or Model 193A is out of specification.

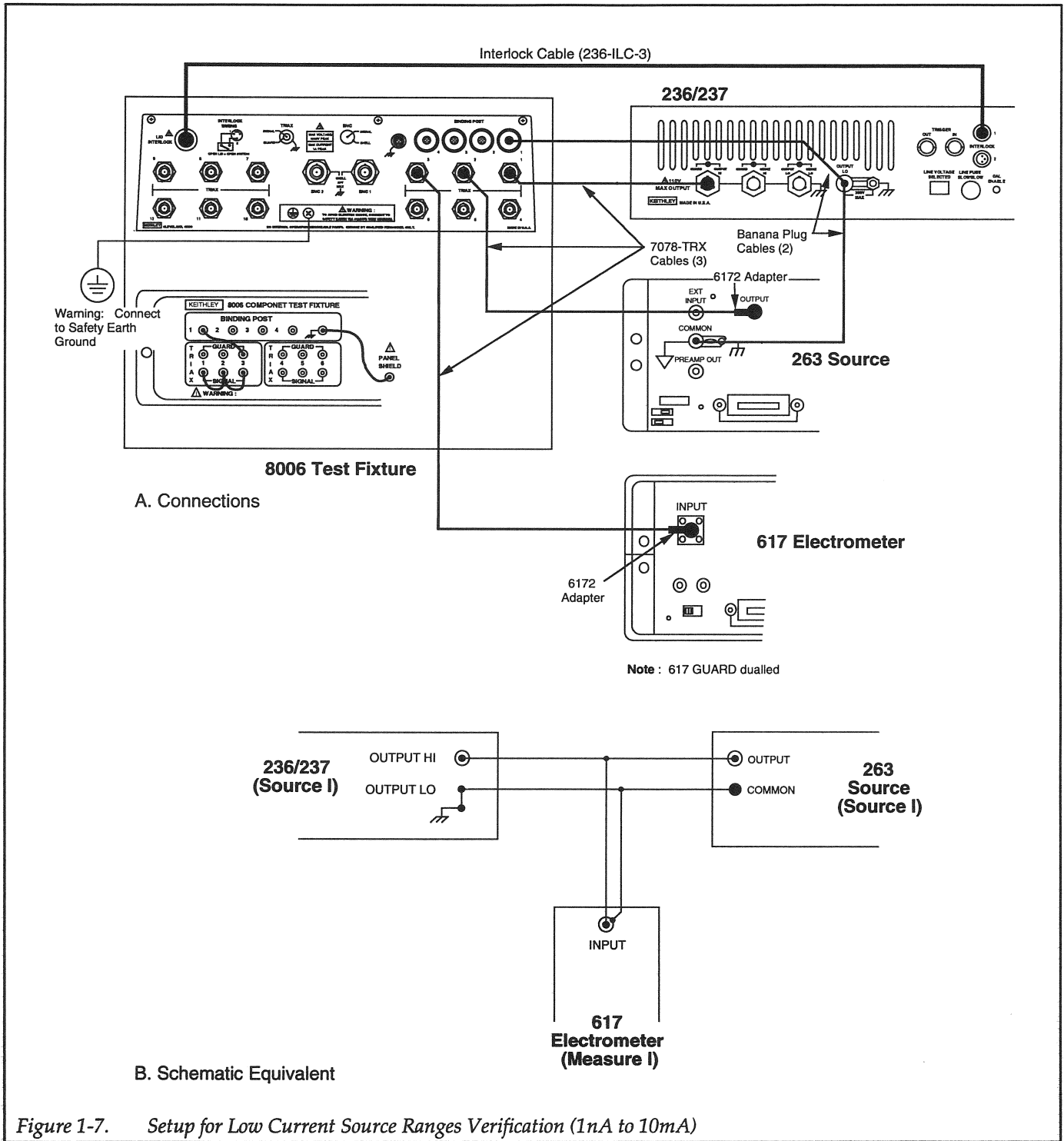

Figure 1-7. Setup for Low Current Source Ranges Verification (1nA to 10mA)

Table 1-9. Low Current Source Verification (1nA to 10mA)

617 Range	263 I-Source		236/237 I-Source*		617 Allowable Readings** (18°C to 28°C)	
	Range	Output Setting	Source Range	Source Value***		
2pA	2nA	Standby	1nA	0nA	-0.4500pA	to +0.4500pA
2pA	2nA	Standby	10nA	0nA	-2.000pA	to +2.000pA
20pA	2nA	Standby	100nA	0nA	-20.00pA	to +20.00pA
200pA	2nA	Standby	1μA	0μA	-200.0pA	to +200.0pA
2nA	2nA	Standby	10μA	0μA	-2.000nA	to +2.000nA
20nA	2nA	Standby	100μA	0μA	-20.00nA	to +20.00nA
200nA	2nA	Standby	1mA	0mA	-200.0nA	to +200.0nA
2μA	2nA	Standby	10mA	0mA	-2.000μA	to +2.000μA
20pA	2nA	+0.9nA -0.9nA	1nA	-0.9nA +0.9nA	-3.150pA	to +3.150pA
200pA	20nA	+9nA -9nA	10nA	-9nA +9nA	-29.00pA	to +29.00pA
200pA	200nA	+90nA -90nA	100nA	-90nA +90nA	-209.0pA	to +209.0pA
2nA	2μA	+0.9μA -0.9μA	1μA	-I _{0.9μA} +I _{0.9μA}	-_____nA	to +_____nA
20nA	20μA	+9μA -9μA	10μA	-I _{9μA} +I _{9μA}	-_____nA	to +_____nA
200nA	200μA	+90μA -90μA	100μA	-I _{90μA} +I _{90μA}	-_____nA	to +_____nA
2μA	2mA	+0.9mA -0.9mA	1mA	-I _{0.9mA} +I _{0.9mA}	-_____μA	to +_____μA
2μA	20mA	+9mA -9mA	10mA	-I _{9mA} +I _{9mA}	-_____μA	to +_____μA

* 236/237 compliance limit set to 1.1V on the 1.1V measurement range.

** Allowable readings for the 1μA thru 10mA source ranges are calculated in Table 1-8.

*** For the 1μA thru 10mA ranges, program the Model 236/237 to source the characterized I-source valued from Table 1-3.

1.5.8 100mA Measure Range Verification

Set up the equipment as shown in Figure 1-8. The 10Ω resistor (R-185-10) is installed in the test socket.

This procedure requires the characterized value of the 10Ω resistor for current calculations. The characterized value of this resistor was previously recorded in step 43 of paragraph 1.5.1. Transfer that resistance value to the space provided below:

$$R_{10\Omega} = \underline{\hspace{2cm}} \Omega$$

Perform the following steps to verify the 100mA measurement range:

1. While in standby, set the Model 236/237 to source 0V on the 1.1V source range, and set compliance to 100mA.
2. Set the Model 193A to the 2V dc range.
3. Zero the Model 193A by shorting its input (VOLTS HI to LO), and enabling ZERO.
4. Remove the short from the input of the Model 193A and set the calibration source (Models 343A and 2500E) to output 0mA.
5. Place the Model 236/237 in operate and record the voltage measurement from the Model 193A in the space below:

$$V_{0mA} = \underline{\hspace{2cm}} V$$

6. Calculate the actual current through the resistor as follows:

$$I_{0mA} = \frac{V_{0mA}}{R_{10\Omega}} = \underline{\hspace{2cm}} mA$$

7. Verify that the current reading (I_{236}) on the Model 236/237 is within the following limits:

$$I_{236} = I_{0mA} \pm 6\mu A$$

8. Set the calibration source to output +90mA.
9. Record the voltage from the Model 193A and calculate the actual current.

$$V_{+90mA} = \underline{\hspace{2cm}} V$$

$$I_{+90mA} = \frac{V_{+90mA}}{R_{10\Omega}} = \underline{\hspace{2cm}} mA$$

10. Verify that the current reading (I_{236}) on the Model 236/237 is within the following limits:

$$I_{236} = I_{+90mA} \pm \{(0.0008) I_{+90mA} + 6\mu A\}$$

11. Set the calibration source to output -90mA.
12. Record the voltage from the Model 193A and calculate the actual current.

$$V_{-90mA} = \underline{\hspace{2cm}} V$$

$$I_{-90mA} = \frac{V_{-90mA}}{R_{10\Omega}} = \underline{\hspace{2cm}} mA$$

13. Verify that the current reading (I_{236}) on the Model 236/237 is within the following limits:

$$I_{236} = I_{-90mA} \pm \{(0.0008) I_{-90mA} + 6\mu A\}$$

14. Place the Models 343A and 236/237 in standby.

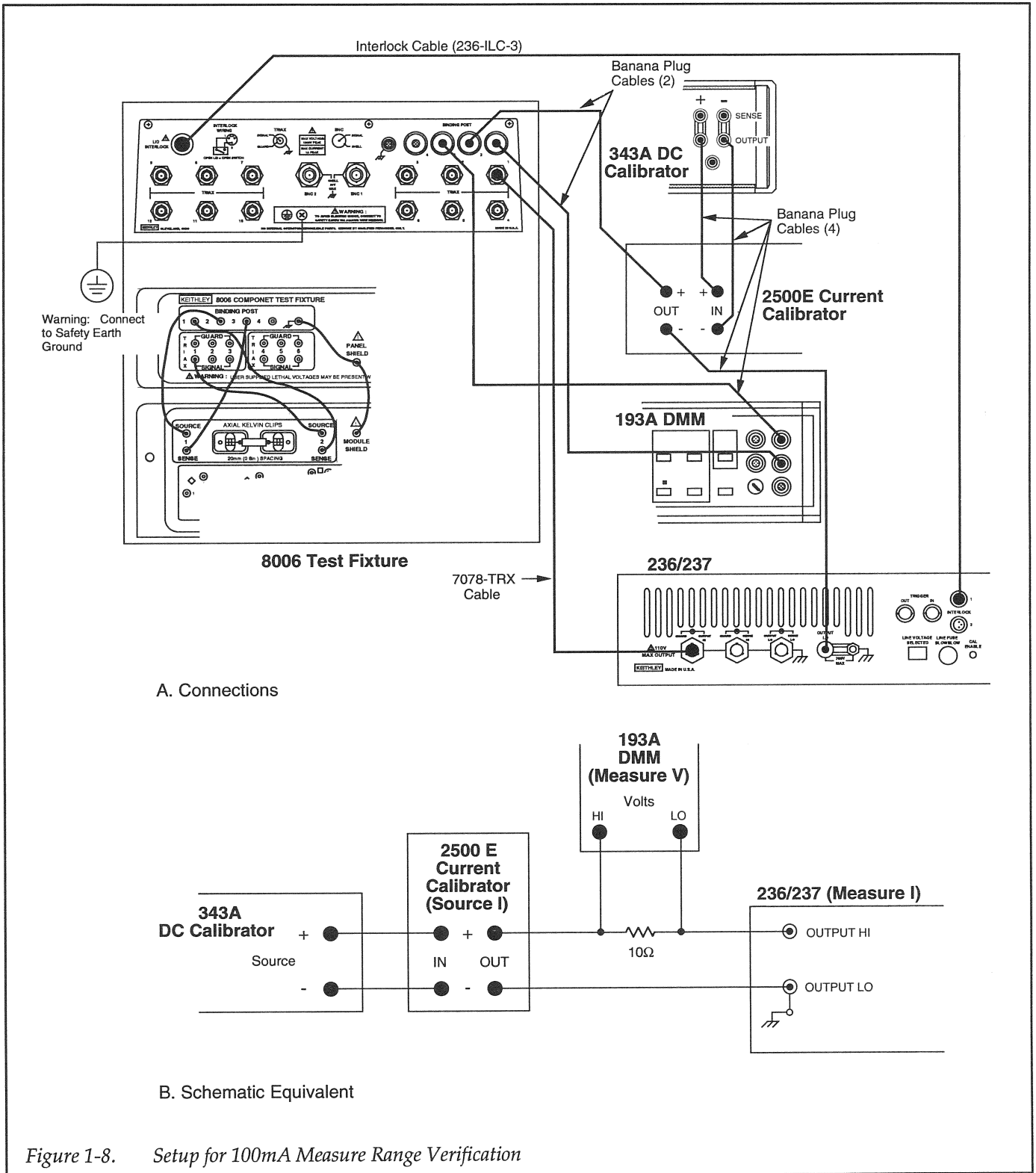

Figure 1-8. Setup for 100mA Measure Range Verification

1.5.9 100mA Source Range Verification

Set up the equipment as shown in Figure 1-9. The 10Ω resistor (R-185-10) is installed in the test socket.

This procedure requires the characterized value of the 10Ω resistor for current calculations. The characterized value of this resistor was previously recorded in step 43 of paragraph 1.5.1 and also used in the previous paragraph. Transfer that resistance value to the space provided below:

$$R_{10\Omega} = \underline{\hspace{2cm}} \Omega$$

Perform the following steps to verify the 100mA source range:

1. While in standby, set the Model 236/237 to source 0mA on the 100mA source range and set compliance to 1.1V.
2. Set the Model 193A to the 2V dc range.
3. Zero the Model 193A by shorting its input (VOLTS HI to LO), and enabling ZERO.
4. Remove the short from the input of the Model 193A.
5. Place the Model 236/237 in operate and record the voltage measurement from the Model 193A in the space below:

$$V_{0mA} = \underline{\hspace{2cm}} V$$

6. Calculate the actual current through the resistor as follows:

$$I_{0mA} = \frac{V_{0mA}}{R_{10\Omega}} = \underline{\hspace{2cm}} mA$$

7. Verify that the actual current (I_{0mA}) is within the following limits:

$$I_{0mA} = 0mA \pm 20\mu A$$

8. Set the Model 236/237 to output +90mA.
9. Record the voltage from the Model 193A and calculate the actual current.

$$V_{+90mA} = \underline{\hspace{2cm}} V$$

$$I_{+90mA} = \frac{V_{+90mA}}{R_{10\Omega}} = \underline{\hspace{2cm}} mA$$

10. Verify that the actual current (I_{+90mA}) is within the following limits:

$$I_{+90mA} = 89.914mA \text{ to } 90.086mA$$

11. Set the Model 236/237 to output -90mA.
12. Record the voltage from the Model 193A and calculate the actual current.

$$V_{-90mA} = \underline{\hspace{2cm}} V$$

$$I_{-90mA} = \frac{V_{-90mA}}{R_{10\Omega}} = \underline{\hspace{2cm}} mA$$

13. Verify that the actual current is within the following limits:

$$I_{-90mA} = -89.914mA \text{ to } -90.086mA$$

14. Place the Model 236/237 in standby.

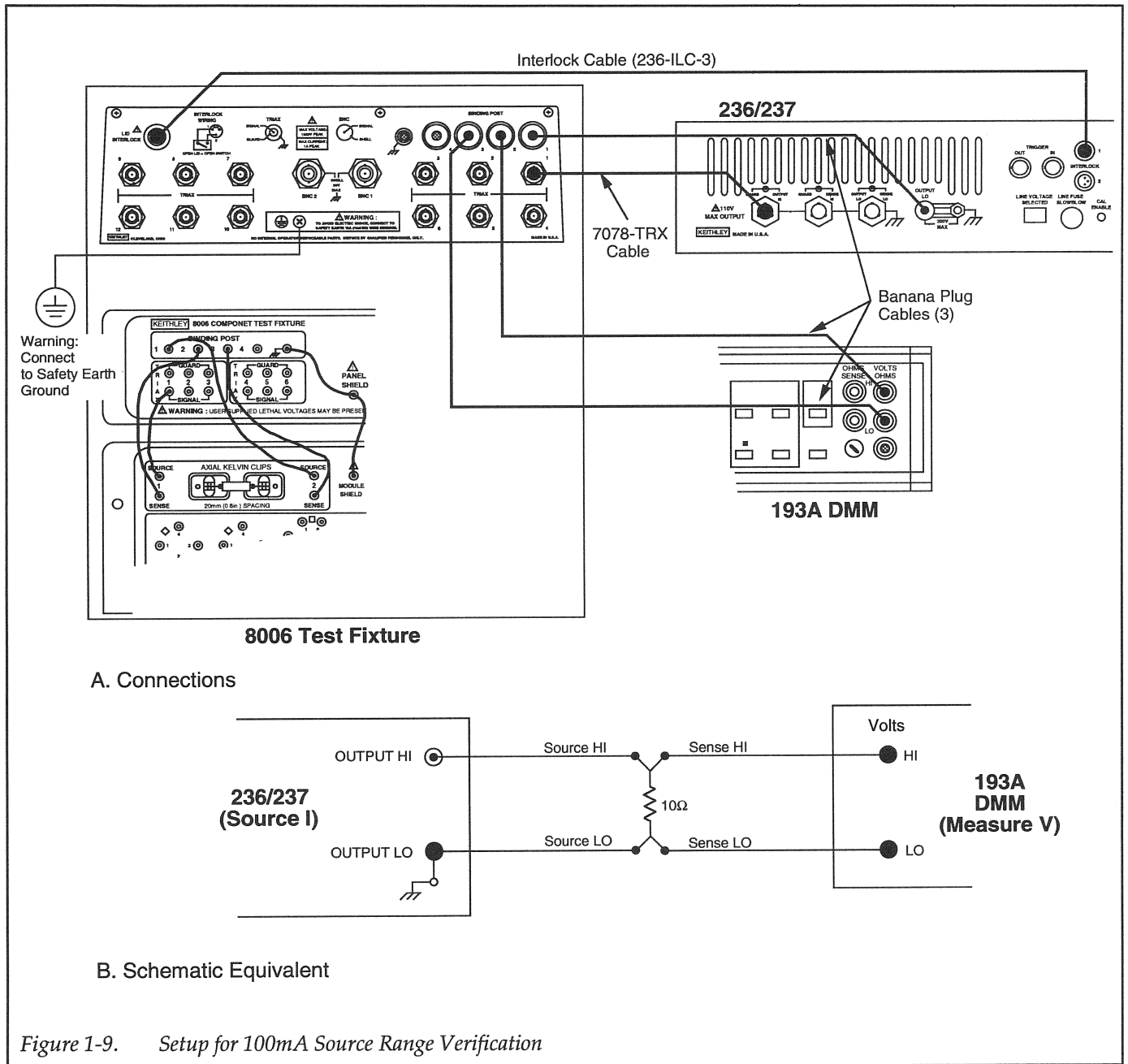

SECTION 2

Calibration

2.1 INTRODUCTION

Calibration should be performed every 12 months, or if the performance verification procedure (Section 1) shows that the Model 236/237 is out of specifications. If any of the calibration steps cannot be performed without error, refer to the troubleshooting information in this manual. If the problem persists, call your Keithley representative or the factory for further information.

Calibration of the Model 236/237 is performed over the IEEE-488 bus. This section contains the step-by-step calibration procedures, and a program written in Microsoft QuickBASIC that can be used.

Before attempting any of the following procedures, make sure you are familiar with the controls and operation of the Model 236/237. Refer to the Model 236/237 Operator's Manual for complete information.

2.2 RECOMMENDED CALIBRATION EQUIPMENT

Table 2-1 lists recommended calibration equipment. Note that the Models 263 and 193A must be within their 90-day specifications as listed in the table. Alternate equipment may be used as long as their accuracy is at least as good as the specifications listed in the Table 2-2.

Table 2-1. Required Test Equipment

Manufacturer	Model	Description	Specifications
Keithley	263	5-1/2 digit Calibrator/Source	2nA, 20nA ranges; $\pm(0.0625\% + 10 \text{ counts})$ 200nA range; $\pm(0.035\% + 10 \text{ counts})$
Keithley	193A	5-1/2 digit DMM	200mV, 2V ranges; $\pm(0.005\% + 2 \text{ counts})$ 20V-1000V ranges; $\pm(0.007\% + 1 \text{ count})$ 200 Ω -200k Ω ranges; $\pm(0.007\% + 2 \text{ counts})$
Keithley	8006	Test Fixture	—
Keithley	R-185-10 R-249-100 R-263-1k R-263-100K	10 Ω Resistor 100 Ω Resistor 1k Ω Resistor 100k Ω Resistor	$\pm 0.1\%$, $\pm 10 \text{ ppm}/^\circ\text{C}$ $\pm 0.1\%$, $\pm 20 \text{ ppm}/^\circ\text{C}$ $\pm 0.1\%$, $\pm 10 \text{ ppm}/^\circ\text{C}$ $\pm 0.1\%$, $\pm 10 \text{ ppm}/^\circ\text{C}$

Table 2-2. Specifications For Alternate Equipment

Instrument Type	Required Specifications
DMM	Same as Keithley 193A (see Table 2-1)
Source dc Current	0.9nA, 9nA, 90nA, Same as Keithley 263 (see Table 2-1) 0.9μA; ±180ppm 9μA, 90μA, 900μA, 9mA; ±170ppm

2.3 ENVIRONMENTAL CONDITIONS

Calibration should be performed under laboratory conditions having an ambient temperature of 23°C ±1°C and a relative humidity of less than 70%.

2.4 WARM-UP PERIOD

WARNING

The Source Measure Unit is equipped with a 3-wire power cord that contains a separate ground wire and is designed to be used with grounded outlets. When proper connections are made, instrument chassis is connected to power line ground. Failure to use a grounded outlet may result in injury or death due to electric shock.

Turn on the Model 236/237 and allow it to warm up for at least one hour before performing the calibration procedures. If the instrument has been subjected to extremes of temperature or humidity, allow at least one additional hour for the internal temperature to stabilize. Typically, it takes one additional hour to stabilize a unit that is 10°C (18°F) outside the specified temperature range.

2.5 CAL LOCK

A switch (CAL LOCK), accessible through the rear panel with a thin shaft screwdriver (see Figure 2-1), is used to prevent inadvertent calibration of the Model 236/237. CAL LOCK is a two position (in and out) pushbutton switch. With the CAL LOCK switch in the locked “out” position, storage of calibration constants in nonvolatile

memory cannot take place. Temporary calibration values can be entered and used with CAL LOCK in the “out” position. However, when power is turned off, the newly entered calibration constants will be lost.

When calibration is performed with CAL LOCK in the unlocked “in” position, calibration constants will be stored in nonvolatile memory when the C59 command is sent over the bus.

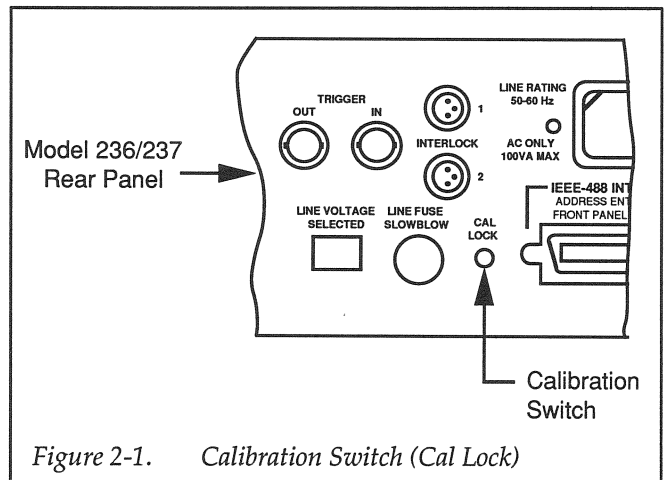

Figure 2-1. Calibration Switch (Cal Lock)

2.6 CALIBRATION PROCEDURES

The step-by-step procedures for calibrating the Model 236/237 are provided here. Calibration is divided into three separate procedures that are independent of one another. That is, any or all (in any order) of the three procedures can be performed. The three procedures include; voltage calibration (paragraph 2.6.2), 100mA calibration

(paragraph 2.6.3) and low current ranges calibration (paragraph 2.6.4).

Calibration is performed using the "C" command over the IEEE-488 bus. Details concerning the use of the "C" command and other commands are contained in Section 3 of the Model 236/237 Operator's Manual.

WARNING

Lethal voltage (up to 1000V for the Model 237) will be connected to the Model 8006 test fixture. To avoid a possible shock hazard, the safety interlock circuit must be connected to the Model 236/237.

Connect the test fixture  screw to safety earth ground using #18 AWG wire minimum before use. Turn off all power before connecting or disconnecting wires or cables.

Also, keep in mind that GUARD is always enabled. Thus, a lethal voltage on OUTPUT HI is also present on the two GUARD terminals of the Model 236/237.

2.6.1 Equipment Characterization

In order to calibrate the 1µA, 10µA, 100µA, 1mA and 10mA source and measure ranges of the Model 236/237, the 0.9µA, 9µA, 90µA, 0.9mA and 9mA outputs of the Model 263 must be characterized. For the 10mA source and measure range, a 10Ω resistor is characterized. Perform the following steps for characterization:

1. Connect the Model 263 source, Model 193A DMM and Model 8006 test fixture as shown in Figure 2-2. Install the 100kΩ resistor (Table 2-1) in the AXIAL KELVIN CLIPS test socket of the test fixture.
2. Configure the source and DMM as follows:
Model 263 — AMPS function, +0.90000µA on 2µA range, GUARD enabled and output in standby.
Model 193A — Ohms function on the 200kΩ range.

3. Zero the Model 193A as follows:
 - A. At the SENSE 1 (HI) terminal of the test socket, disconnect the jumper whose other end is connected to BINDING POST 2 on the Signal Panel.
 - B. Connect that jumper to the SENSE 2 (LO) terminal of the the test socket. This shorts the Ohms Sense input of the Model 193A at the test socket.
 - C. On the Model 193A, enable ZERO to cancel test lead resistance.
 - D. Relocate the jumper back to the SENSE 1 terminal of the test socket. Make sure the connections at the Component Test Module are correct as shown in Figure 2-2.
4. In the space provided below, use a pencil to record the actual value of the 100kΩ resistor from the display of the Model 193A.

$$R_{100k\Omega} = \text{_____} \text{ k}\Omega$$

5. Set the Model 193A to the DCV function and the 200mV range, and disable ZERO.
6. To cancel any offset, zero the Model 193A by shorting its input (VOLTS HI to LO) and enabling ZERO.
7. Remove the short from the input of the Model 193A and place the Model 263 in operate to source +0.90000µA to the 100kΩ resistor.
8. In the space below, use a pencil to record the voltage drop across the resistor from the display of the Model 193A.

$$V_{100k\Omega} = \text{_____} \text{ mV}$$

9. Calculate (to 5-1/2d) the current through the 100kΩ resistor as follows:

$$I_{0.9\mu A} = \frac{V_{100k\Omega}}{R_{100k\Omega}} = \text{_____} \mu A$$

$I_{0.9\mu A}$ is the characterized current for the 2µA range of the Model 263. It is used to calibrate the 1µA range of the Model 236/237. Using a pencil, record the calculated value of $I_{0.9\mu A}$ in Entry 1 of Table 2-3.

10. Place the Model 263 in standby.
11. Set the Model 193A to the 2V range.
12. Set the Model 263 to source 9.0000µA on the 20µA range and enable OPERATE.

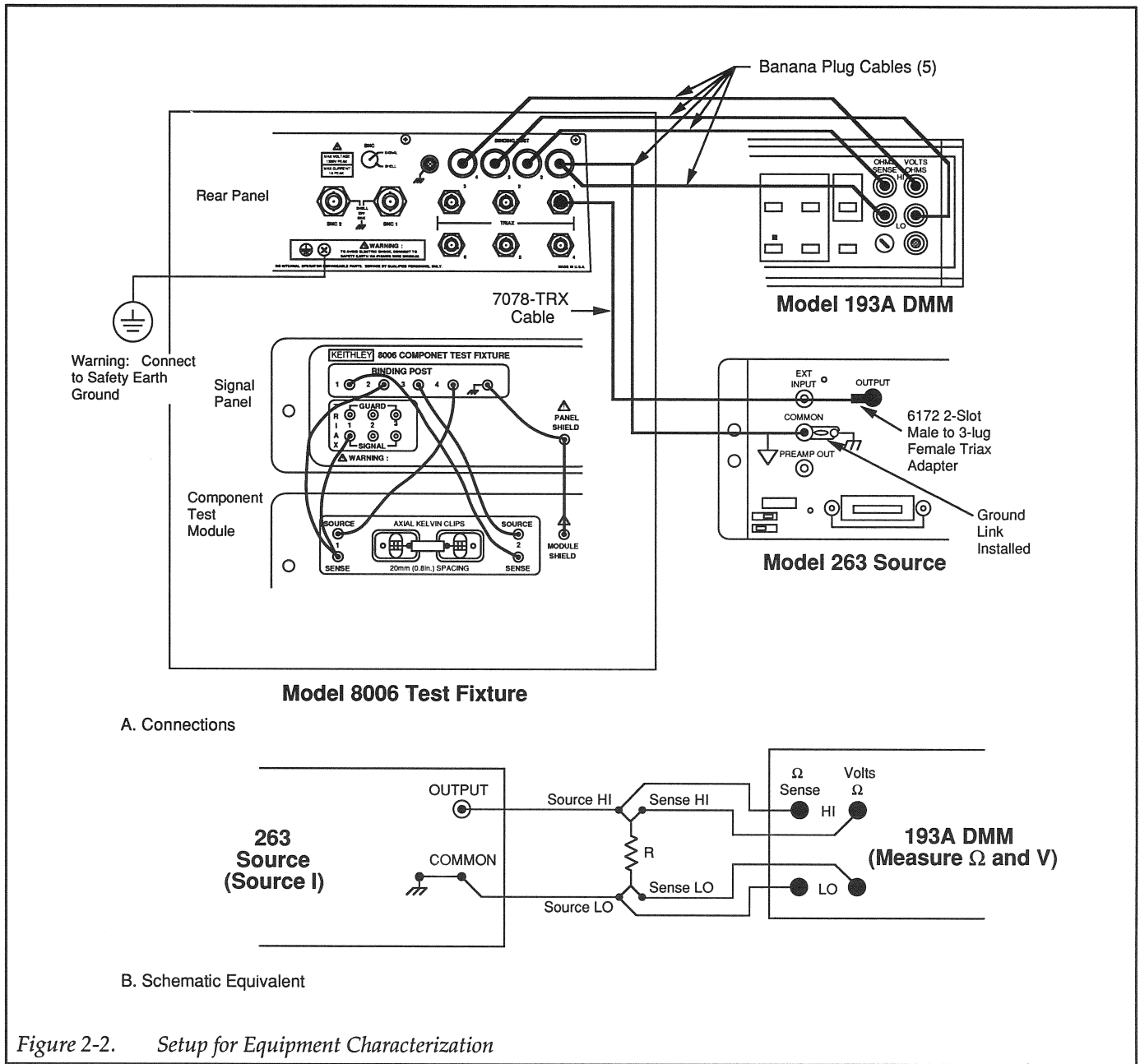

Figure 2-2. Setup for Equipment Characterization

13. As performed in steps 8 and 9, measure the voltage across the 100kΩ resistor and calculate the current.

$$V_{100k\Omega} = \underline{\hspace{2cm}} \text{ V}$$

$$I_{9\mu A} = \frac{V_{100k\Omega}}{R_{100k\Omega}} = \underline{\hspace{2cm}} \mu A$$

$I_{9\mu A}$ is the characterized current for the 20μA range of the Model 263. It is used to calibrate the 10μA range of the Model 236/237. Using a pencil, record the calculated value of $I_{9\mu A}$ in Entry 2 of Table 2-3.

14. Place the Model 263 in standby.
 15. In the test fixture, remove the 100kΩ resistor and install the 1kΩ resistor (R-263-1k).
 16. On the Model 193A, select the Ohms function, 2kΩ range and disable ZERO.
 17. Repeat step 3 to zero the Model 193A.
 18. Measure and record the value of the 1kΩ resistor.

$$R_{1k\Omega} = \underline{\hspace{2cm}} \text{ k}\Omega$$

19. Set the Model 193A to DCV and the 200mV range, and disable ZERO.
 20. To cancel any offset, zero the Model 193A by shorting its input (VOLTS HI to LO) and enabling ZERO.
 21. Remove the short from the input of the Model 193A and set the Model 263 to source 90.000μA on the 200μA range and enable OPERATE.

22. Record the voltage measurement from the Model 193A and calculate the current.

$$V_{1k\Omega} = \underline{\hspace{2cm}} \text{ mV}$$

$$I_{90\mu A} = \frac{V_{1k\Omega}}{R_{1k\Omega}} = \underline{\hspace{2cm}} \mu A$$

$I_{90\mu A}$ is the characterized current for the 200μA range of the Model 263. It is used to calibrate the 100μA range of the Model 236/237. Using a pencil, record the calculated value of $I_{90\mu A}$ in Entry 3 of Table 2-3.

23. Place the Model 263 in standby.
 24. Set the Model 193A to the 2V range.
 25. Set the Model 263 to source 0.90000mA on the 2mA range, and enable OPERATE.
 26. Record the voltage measurement from the Model 193A and calculate the current.

$$V_{1k\Omega} = \underline{\hspace{2cm}} \text{ V}$$

$$I_{0.9mA} = \frac{V_{1k\Omega}}{R_{1k\Omega}} = \underline{\hspace{2cm}} \mu A$$

$I_{0.9mA}$ is the characterized current for the 2mA range of the Model 263. It is used to calibrate the 1mA range of the Model 236/237. Using a pencil, record the calculated value of $I_{0.9mA}$ in Entry 4 of Table 2-3.

27. Place the Model 263 in standby.
 28. In the test fixture, remove the 1kΩ resistor and install the 100Ω resistor (R-249-100).

Table 2-3. Model 263 I-Source Characterization

Entry	263 I-Source		Characterized I-Source Value	I-Source Value Limits*
	Range	Programmed Value		
1	2μA	0.90000μA	$I_{0.9\mu A} = \underline{\hspace{2cm}}$	0.9μA ±450pA
2	20μA	9.000μA	$I_{9\mu A} = \underline{\hspace{2cm}}$	9μA ±4.3nA
3	200μA	90.000μA	$I_{90\mu A} = \underline{\hspace{2cm}}$	90μA ±45nA
4	2mA	0.9000mA	$I_{0.9mA} = \underline{\hspace{2cm}}$	0.9mA ±430nA
5	20mA	9.0000mA	$I_{9mA} = \underline{\hspace{2cm}}$	9mA ±5.4μA

*The characterized I-source values should be within the listed limits. These limits are based on the 90-day specifications of the Model 263 and 193A. A characterized value that does not fall within these limits indicates a calculation error, or that the Model 263 and/or Model 193A is out of specification.

29. On the Model 193A, select the Ohms function, 200Ω range and disable ZERO.
30. Repeat step 3 to zero the Model 193A.
31. Measure and record the value of the 100Ω resistor.

$$R_{100\Omega} = \text{_____} \Omega$$

32. Set the Model 193A to DCV, the 2V range, and disable ZERO.
33. To cancel any offset, zero the Model 193A by shorting its input (VOLTS HI to LO), and enabling ZERO.
34. Remove the short from the input of the Model 193A and set the Model 263 to source 9.0000mA on the 20mA range and enable OPERATE.
35. Record the voltage measurement from the Model 193A and calculate the current.

$$V_{100\Omega} = \text{_____} V$$

$$I_{9mA} = \frac{V_{100\Omega}}{R_{100\Omega}} = \text{_____} mA$$

I_{9mA} is the characterized current for the 9mA range of the Model 263. It is used to calibrate the 10mA range of the Model 236/237. Using a pencil, record the calculated value of I_{9mA} in Entry 5 of Table 2-3.

36. Place the Model 263 in standby.
37. In the test fixture, remove the 100Ω resistor and install the 10Ω resistor (R-185-10).
38. On the Model 193A DMM, disable ZERO and select the 200mVDC range.
39. While in standby, set the Model 263 to +9.0000mA on the 20mA range.
40. Zero the Model 193A by shorting its input (VOLTS HI to LO) and enabling ZERO.
41. Remove the short from the input of the Model 193A and place the Model 263 in operate.
42. Record the voltage measurement from the Model 193A and then place the Model 263 in standby.

$$V_{10\Omega} = \text{_____} mV$$

43. Calculate the actual resistance of the 10Ω resistor as follows:

$$R_{10\Omega} = \frac{V_{10\Omega}}{I_{9mA}} = \text{_____} \Omega$$

where; I_{9mA} is obtained from Table 2-3.

$R_{10\Omega}$ is used to calibrate the 100mA range of the Model 236/237.

NOTE

To store calibration constants in nonvolatile memory, place the CAL LOCK switch to the unlocked "in" position (see paragraph 2.5). With the switch in the locked "out" position, calibration will be temporary. That is, the new calibration constants will be lost when the instrument is turned off.

2.6.2 Voltage Calibration

For voltage calibration, connect the Model 193A DMM to the Model 236/237 via the Model 8006 test fixture as shown in Figure 2-3. Jumper A is initially installed to short the output of the Model 236/237 and the input of the Model 193A.

WARNING

The following procedure uses hazardous voltages (1000V for the Model 237) that could cause injury or death. Exercise extreme caution when encountering these lethal voltage levels. Make sure to connect the Model 8006 Interlock Circuit to the Model 236/237

Perform the following steps to calibrate the voltage source and measure ranges:

1. Set the Model 193A DMM to DC volts and autorange.
2. With the short (Jumper A) installed, zero the Model 193A by enabling ZERO.
3. Place the Model 236/237 in operate. The calibration mode cannot be entered with the Model 236/237 in standby.
4. Over the IEEE-488 bus, send the following command to enter the calibration mode:

C0X ! Enter calibration mode

Note: All other calibration commands (C1 through C59) will be ignored unless the C0 command is first sent over the bus.

5. With the short still installed, send the following command over the bus to perform common mode calibration:

C1X ! Calibrate common mode

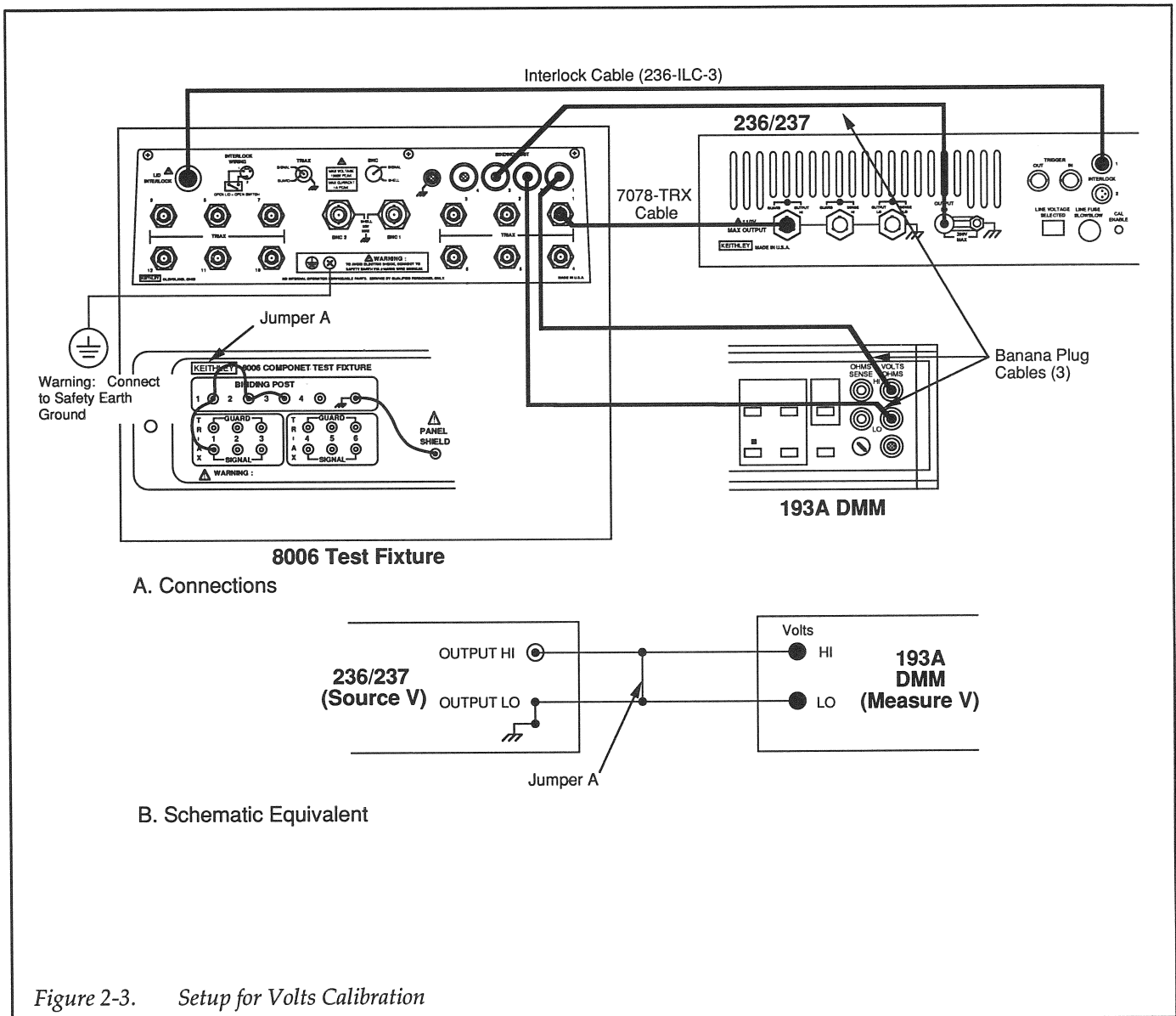

Figure 2-3. Setup for Volts Calibration

Note: Common mode calibration takes approximately 30 seconds to complete.

- Remove the short (Jumper A) and send the following command to source +0V on the 1.1V range:

C2X ! Source +0.0000V

- The voltage offset for this range is measured by the Model 193A. Send the measured voltage reading (V_{MSR}) with the C3 command as follows:

C3, $V_{MSR}X$! Calibrate offset; +1.1V source and measure range

For example, if the reading on the Model 193A is +0.00036 V, send C3,.00036X or C3,36E-5X over the bus.

- Send the following command to source +1V on the 1.1V range:

C4X ! Source +1.0000V

- Send the measured voltage reading (V_{MSR}) from the Model 193A over the bus with the C5 command as follows:

C5, $V_{MSR}X$! Calibrate gain; +1.1V source and measure range

- | | |
|--|---|
| <p>10. Send the following command to source -0V on the 1.1V range:</p> <p style="padding-left: 40px;">C6X ! Source -0.0000V</p> <p>11. Send the measured voltage reading (V_{MSR}) over the bus with the C7 command as follows:</p> <p style="padding-left: 40px;">C7,$V_{MSR}X$! Calibrate offset; -1.1V source and measure range</p> <p>12. Send the following command to source -1V on the 1.1V range:</p> <p style="padding-left: 40px;">C8X ! Source -1.0000V</p> <p>13. Send the measured voltage reading (V_{MSR}) over the bus with the C9 command as follows:</p> <p style="padding-left: 40px;">C9,$V_{MSR}X$! Calibrate gain; -1.1V source and measure range</p> <p>14. Send the following command to source +0V on the 11V range:</p> <p style="padding-left: 40px;">C10X ! Source +00.000V</p> <p>15. Send the measured voltage reading (V_{MSR}) over the bus with the C11 command as follows:</p> <p style="padding-left: 40px;">C11,$V_{MSR}X$! Calibrate offset; +11V source and measure range</p> <p>16. Send the following command to source +10V on the 11V range:</p> <p style="padding-left: 40px;">C12X ! Source +10.000V</p> <p>17. Send the measured voltage reading (V_{MSR}) over the bus with the C13 command as follows:</p> <p style="padding-left: 40px;">C13,$V_{MSR}X$! Calibrate gain; +11V source and measure range</p> <p>18. Send the following command to source -0V on the 11V range:</p> <p style="padding-left: 40px;">C14X ! Source -00.000V</p> <p>19. Send the measured voltage reading (V_{MSR}) over the bus with the C15 command as follows:</p> <p style="padding-left: 40px;">C15,$V_{MSR}X$! Calibrate offset; -11V source and measure range</p> | <p>20. Send the following command to source -10V on the 11V range:</p> <p style="padding-left: 40px;">C16X ! Source -10.000V</p> <p>21. Send the measured voltage reading (V_{MSR}) over the bus with the C17 command as follows:</p> <p style="padding-left: 40px;">C17,$V_{MSR}X$! Calibrate gain; -11V source and measure range</p> <p>22. Send the following command to source +0V on the 110V range:</p> <p style="padding-left: 40px;">C18X ! Source +000.00V</p> <p>23. Send the measured voltage reading (V_{MSR}) over the bus with the C19 command as follows:</p> <p style="padding-left: 40px;">C19X,$V_{MSR}X$! Calibrate offset; +110V source and measure range</p> <p>24. Send the following command to source +100V on the 110V range:</p> <p style="padding-left: 40px;">C20X ! Source +100.00V</p> <p>25. Send the measured voltage reading (V_{MSR}) over the bus with the C21 command as follows:</p> <p style="padding-left: 40px;">C21,$V_{MSR}X$! Calibrate gain; +110V source and measure range</p> <p>26. Send the following command to source -0V on the 110V range:</p> <p style="padding-left: 40px;">C22X ! Source -000.00V</p> <p>27. Send the measured voltage reading (V_{MSR}) over the bus with the C23 command as follows:</p> <p style="padding-left: 40px;">C23,$V_{MSR}X$! Calibrate offset; -110V source and measure range</p> <p>28. Send the following command to source -100V on the 110V range:</p> <p style="padding-left: 40px;">C24X ! Source -100.00V</p> <p>29. Send the measured voltage reading (V_{MSR}) over the bus with the C25 command as follows:</p> <p style="padding-left: 40px;">C25,$V_{MSR}X$! Calibrate gain; -110V source and measure range</p> <p>Note: Steps 30 through 37 apply only to the Model 237. If calibrating the Model 236, proceed to step 38.</p> |
|--|---|

30. Send the following command to source +0V on the 1100V range:

V1X ! Enable 1100V range
C26X ! Source +0000.0V

31. Send the measured voltage reading (V_{MSR}) over the bus with the C27 command as follows:

C27, $V_{MSR}X$! Calibrate offset; +1100V
 source and measure range

32. Send the following command to source +1000V:

C28X ! Source +1000.0V

33. Send the measured voltage reading (V_{MSR}) over the bus with the C29 command as follows:

C29, $V_{MSR}X$! Calibrate gain; +1100V source
 and measure range

34. Send the following command to source -0V on the 1100V range:

C30X ! Source -0000.0V

35. Send the measured voltage reading (V_{MSR}) over the bus with the C31 command as follows:

C31, $V_{MSR}X$! Calibrate offset; -1100V source
 and measure range

36. Send the following command to source -1000V:

C32X ! Source -1000.0V

37. Send the measured voltage reading (V_{MSR}) over the bus with the C33 command as follows:

C33, $V_{MSR}X$! Calibrate gain; -1100V source
 and measure range

38. Send the following command over the bus:

Note: Check that the CAL LOCK switch is in the desired position; "in" for permanent calibration, or "out" for temporary calibration.

C59X ! Exit calibration and store cal
 constants.

If the switch is in the "out" position, the message "TEMPORARY CAL" will be briefly displayed to indicate that newly entered cal constants will be lost

when the Model 236/237 is turned off. Permanent calibration can still be done by setting the calibration switch to the "in" position, and sending C0X and C59X over the bus in that order.

After sending the C59X command, the Model 236/237 will return to normal operation.

39. Place the Model 236/237 in standby.
40. Send the following command over the bus to disable the 1100V range:

V0X ! Disable 1100V range

2.6.3 100mA Range Calibration

To calibrate the 100mA range, connect the circuit shown in Figure 2-4. The 10 Ω resistor installed in the test fixture is one that was previously characterized in the equipment characterization procedure. Note that the accuracy of this calibration is highly dependent on the accuracy of the characterized value of the 10 Ω resistor. Enter the characterized value of the 10 Ω resistor (see paragraph 2.6.1, step 43) in the space below:

$R_{10\Omega} =$ _____ Ω

Perform the following steps to calibrate the 100mA source and measure range:

1. Temporarily disconnect the output of the Model 236/237 from the test fixture.
2. Set the Model 193A DMM to the 2VDC range and then enable ZERO to cancel any offset.
3. Re-connect the output of the Model 236/237 to the test fixture.
4. Place the Model 236/237 in operate. The calibration mode cannot be entered with the Model 236/237 in standby.
5. Over the IEEE-488 bus, send the following command to enter the calibration mode:

C0X ! Enter calibration mode

Note: All other calibration commands (C1 through C59) will be ignored unless the C0 command is first sent over the bus.

6. Send the following command to source +0mA on the 100mA range:

C34X ! Source +000.00mA

7. From the display of the Model 193A DMM, record the voltage drop across the 10 Ω resistor ($V_{10\Omega}$) in the space below.

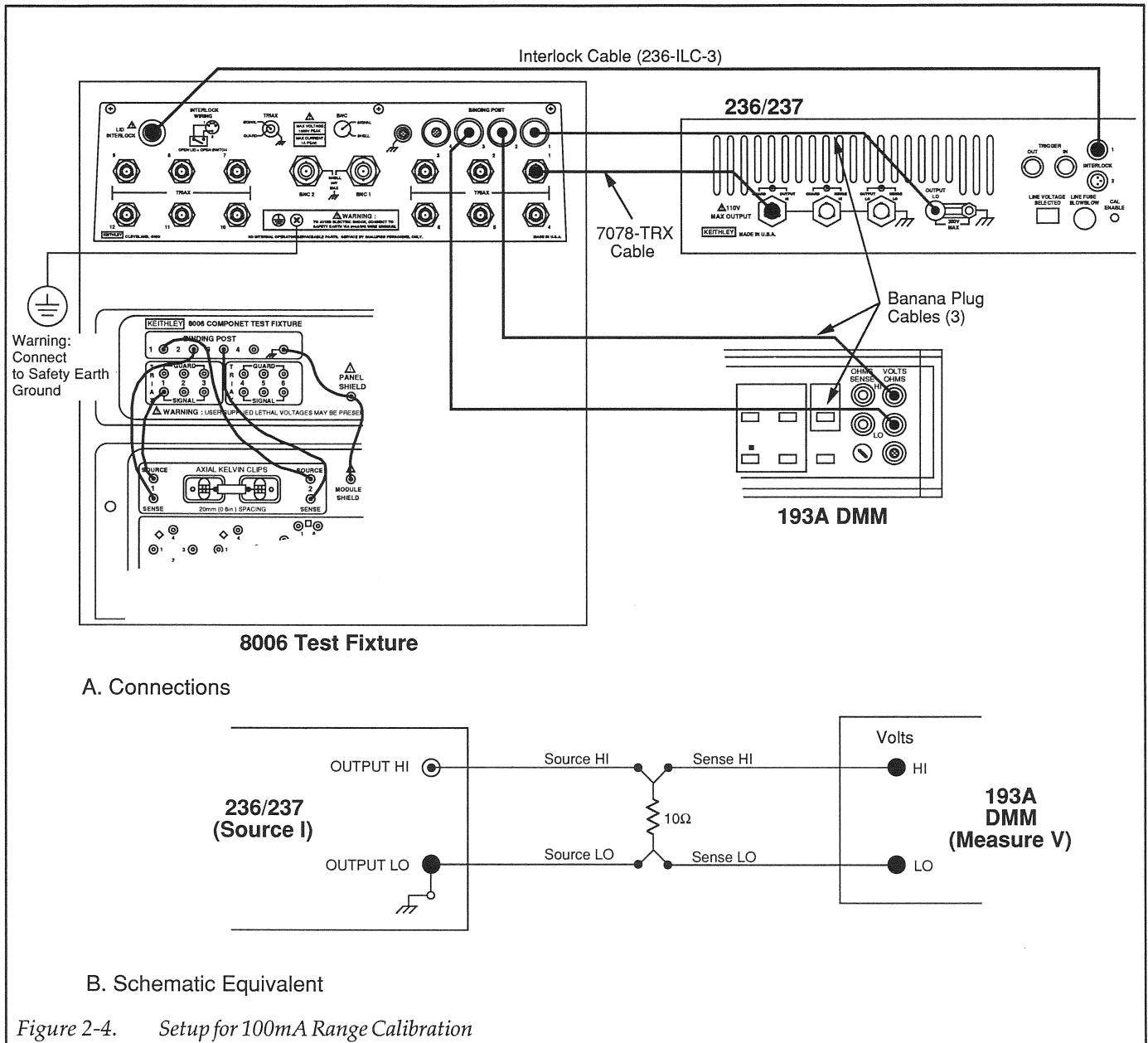

Figure 2-4. Setup for 100mA Range Calibration

$$V_{10\Omega} = \underline{\hspace{2cm}} \text{ V}$$

C35, I_{+0mA}X ! Calibrate offset; +100mA source and measure range

8. Calculate the actual offset current (I_{+0mA}) using the following calculation:

$$I_{+0mA} = \frac{V_{10\Omega}}{R_{10\Omega}} = \underline{\hspace{2cm}} \text{ mA}$$

9. Send the calculated current reading (I_{+0mA}) over the bus with the C35 command as follows:

10. Send the following command to source +90mA:

C36X ! Source +90.00mA

11. From the display of the Model 193A DMM, record the voltage drop across the 10Ω resistor (V_{10Ω}) in the space below.

$$V_{10\Omega} = \underline{\hspace{2cm}} \text{ V}$$

12. Calculate the actual current ($I_{+90\text{mA}}$) using the following calculation:

$$I_{+90\text{mA}} = \frac{V_{10\Omega}}{R_{10\Omega}} = \underline{\hspace{2cm}} \text{ mA}$$

13. Send the calculated current reading ($I_{+90\text{mA}}$) over the bus with the C37 command as follows:

C37, $I_{+90\text{mA}}X$! Calibrate gain; +100mA source and measure range

14. Send the following command to source -0mA on the 100mA range:

C38X ! Source -000.00mA

15. From the display of the Model 193A DMM, record the voltage drop across the 10Ω resistor ($V_{10\Omega}$) in the space below.

$$V_{10\Omega} = \underline{\hspace{2cm}} \text{ V}$$

16. Calculate the actual offset current ($I_{-0\text{mA}}$) using the following calculation:

$$I_{-0\text{mA}} = \frac{V_{10\Omega}}{R_{10\Omega}} = \underline{\hspace{2cm}} \text{ mA}$$

17. Send the calculated current reading ($I_{-0\text{mA}}$) over the bus with the C39 command as follows:

C39, $I_{-0\text{mA}}X$! Calibrate offset; -100mA source and measure range

18. Send the following command to source -90mA:

C40X ! Source -90.00mA

19. From the display of the Model 193A DMM, record the voltage drop across the 10Ω resistor ($V_{10\Omega}$) in the space below.

$$V_{10\Omega} = \underline{\hspace{2cm}} \text{ V}$$

20. Calculate the actual current ($I_{-90\text{mA}}$) using the following calculation:

$$I_{-90\text{mA}} = \frac{V_{10\Omega}}{R_{10\Omega}} = \underline{\hspace{2cm}} \text{ mA}$$

21. Send the calculated current reading ($I_{-90\text{mA}}$) over the bus with the C41 command as follows:

C41, $I_{-90\text{mA}}X$! Calibrate gain; -100mA source and measure range

Note: Check that the CAL LOCK switch is in the desired position; "in" for permanent calibration, or "out" for temporary calibration.

22. Send the following command over the bus:

C59X ! Exit calibration and store cal constants.

If the switch is in the "out" position, the message "TEMPORARY CAL" will be briefly displayed to indicate that newly entered cal constants will be lost when the Model 236/237 is turned off. Permanent calibration can still be done by setting the calibration switch to the "in" position, and sending C0X and C59X over the bus in that order.

After sending the C59X command, the Model 236/237 will return to normal operation.

23. Place the Model 236/237 in standby.

2.6.4 Low Current Ranges Calibration (1nA – 10mA)

Connect the characterized Model 263 calibrator to the Model 236/237 as shown in Figure 2-5. The characterized I-source values ($I_{0.9\mu\text{A}}$, $I_{9\mu\text{A}}$, $I_{90\mu\text{A}}$, $I_{0.9\text{mA}}$ and $I_{9\text{mA}}$) of the Model 263 that are used to calibrate the $1\mu\text{A}$ through 10mA ranges were determined in the equipment characterization procedure (paragraph 2.6.1) and recorded in Table 2-3.

Perform the following steps to calibrate the 1nA through 10mA measurement ranges:

NOTE

If controlling the Model 263 from the front panel, always select the lowest possible current range. Over the bus, AUTO range can be used.

1. In standby, set the Model 263 to 0.9nA and enable GUARD.
2. Place the Model 236/237 in OPERATE. The calibration mode cannot be entered with the Model 236/237 in standby.

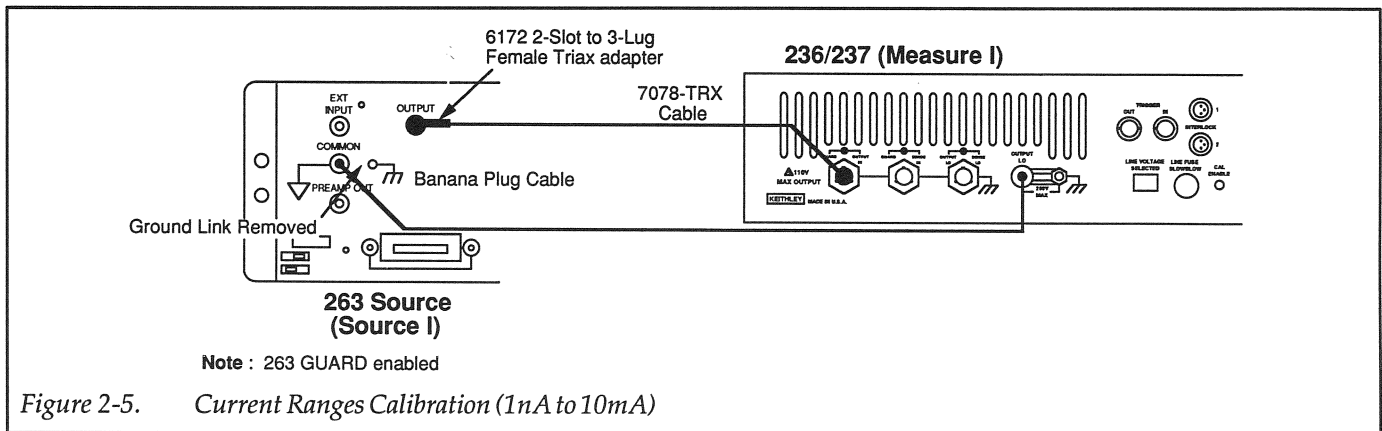

Figure 2-5. Current Ranges Calibration (1nA to 10mA)

- Over the IEEE-488 bus, send the following command to enter the calibration mode:

C0X ! Enter calibration mode

Note: All other calibration commands (C1 through C59) will be ignored unless the C0 command is first sent over the bus.

- Send the following command over the IEEE-488 bus:

C42X ! Calibrate offset; 1nA measure range

Note: Calibration takes \approx 20 seconds to complete.

- Place the Model 263 in OPERATE to source 0.9nA to the Model 236/237.
- Send the following command over the bus:

C43,0.9E-9X ! Calibrate gain; 1nA measure range

Note: Calibration takes \approx 20 seconds to complete.

- Place the Model 263 in standby and set it to 9nA.
- Send the following command over the bus:

C44X ! Calibrate offset; 10nA measure range

Note: Calibration takes \approx 10 seconds to complete.

- Place the Model 263 in operate to source 9nA to the Model 236/237.
- Send the following command over the bus:

C45,9E-9X ! Calibrate gain; 10nA measure range

Note: Calibration takes \approx 10 seconds to complete.

- Place the Model 263 in standby and set it to 90nA.
- Send the following command over the bus:

C46X ! Calibrate offset; 100nA measure range

Note: Calibration takes \approx 4 seconds to complete.

- Place the Model 263 in OPERATE to source 90nA to the Model 236/237.
- Send the following command over the bus:

C47,90E-9X ! Calibrate gain; 100nA measure range

Note: Calibration takes \approx 4 seconds to complete.

- Place the Model 263 in standby and set it to 0.9 μ A.
- Send the following command over the bus:

C48X ! Calibrate offset; 1 μ A measure range

- Place the Model 263 in OPERATE.
- Send $I_{0.9\mu A}$ (from Table 2-3) over the bus with the C49 command as follows:

C49, $I_{0.9\mu A}X$! Calibrate gain; 1 μ A measure range

For example, if $I_{0.9\mu A} = 0.90036\mu A$, send C49,0.90036E-6X.

- Place the Model 263 in standby and set it to 9 μ A.
- Send the following command over the bus:

C50X ! Calibrate offset; 10 μ A measure range

21. Place the Model 263 in OPERATE.
22. Send $I_{9\mu A}$ (from Table 2-3) over the bus with the C51 command as follows:

C51, $I_{9\mu A}X$! Calibrate gain; 10 μA measure range

23. Place the Model 263 in standby and set it to 90 μA .
24. Send the following command over the bus:

C52X ! Calibrate offset; 100 μA measure range

25. Place the Model 263 in OPERATE.
26. Send $I_{90\mu A}$ (from Table 2-3) over the bus with the C53 command as follows:

C53, $I_{90\mu A}X$! Calibrate gain; 100 μA measure range

27. Place the Model 263 in standby and set it to 0.9mA.
28. Send the following command over the bus:

C54X ! Calibrate offset; 1mA measure range

29. Place the Model 263 in OPERATE.
30. Send $I_{0.9mA}$ (from Table 2-3) over the bus with the C55 command as follows:

C55, $I_{0.9mA}X$! Calibrate gain; 1mA measure range

31. Place the Model 263 in standby and set it to 9mA.
32. Send the following command over the bus:

C56X ! Calibrate offset; 10mA measure range

33. Place the Model 263 in operate.
34. Send I_{9mA} (from Table 2-3) over the bus with the C57 command as follows:

C57, $I_{9mA}X$! Calibrate gain; 10mA measure range

35. Place the Model 263 in standby and set it to 0mV.
36. Place the Model 263 in operate.
37. Send the following command over the bus:

C58X ! Calibrate 1nA to 10mA source ranges

Note: Calibration of the low current source ranges takes approximately four minutes to complete.

Note: Check that the CAL LOCK switch is in the desired position; "in" for permanent calibration, or "out" for temporary calibration.

38. Send the following command over the bus:

C59X ! Exit calibration and store cal constants.

If the switch is in the "out" position, the message "TEMPORARY CAL" will be briefly displayed to indicate that newly entered cal constants will be lost when the Model 236/237 is turned off. Permanent calibration can still be done by setting the calibration switch to the "in" position, and sending C0X and C59X over the bus in that order.

After sending the C59X command, the Model 236/237 will return to normal operation.

39. Place the Models 263 and 236/237 in standby.

2.7 CALIBRATION ERRORS

Calibration errors and subsequent error messages that could occur during calibration are explained in Table 2-4. It is important to realize that if any of these errors (except INCAL) occur, calibration is compromised. Even though some errors will cause default cal constants to be used, they do not guarantee specified accuracy. When a calibration error occurs, find and fix the problem and repeat calibration.

Since calibration error messages are briefly displayed by the Model 236/237, they can be easily overlooked. For this reason it is strongly recommended that calibration errors be detected and displayed by the calibration program. The following steps provide the general procedure required to detect calibration errors over the IEEE-488 bus:

Table 2-4. Calibration Error Messages

Message	Explanation
IN CAL	Tried to set the instrument to a state that is illegal while in the calibration mode. Legal commands include; C (calibration), N (operate/standby), O (output sense) and U (status). From the front panel, only operate/standby and output sense can be set. All illegal commands and operations are ignored.
IN STBY	The Model 236/237 is in standby. The calibration command sent over the bus will not be executed (see Note).
CAL COMPLI	Compliance has occurred during calibration. Check test setup connections and instrument settings.
CAL MODE ERR	Common mode calibration error. Output of Model 236/237 is not shorted or unit is defective. The cal constant from the previous calibration will be used.
CAL VALUE ERR	Invalid calibration value sent to the Model 236/237. This calibration step is ignored (not attempted). Calibration constant from previous calibration will be used.
CAL ADC ZERO	Measure offset calibration error. Calibration is attempted using a value that is not within acceptable limits. The transmitted value is ignored and a default cal constant value is used instead. Possible problems include; incorrect cal constant value, defective calibration equipment (or connections), or defective Model 236/237.
CAL ADC GAIN	Measure gain calibration error. Calibration is attempted using a value that is not within acceptable limits. The transmitted value is ignored and a default cal constant value is used instead. Possible problems include; incorrect cal constant value, defective calibration equipment (or connections), or defective Model 236/237.
CAL SRC ZERO	Source offset calibration error. Calibration is attempted using a value that is not within acceptable limits. The transmitted value is ignored and a default cal constant value is used instead. Possible problems include; incorrect cal constant value, defective calibration equipment (or connections), or defective Model 236/237.
CAL SRC GAIN	Source gain calibration error. Calibration is attempted using a value that is not within acceptable limits. The transmitted value is ignored and a default cal constant value is used instead. Possible problems include; incorrect cal constant value, defective calibration equipment (or connections), or defective Model 236/237.

Note: During the execution of a calibration step in which the Model 236/237 takes a measurement conversion, it is possible the instrument can transition from OPERATE to STANDBY. This can occur because it was specifically programmed to do so, or because the test fixture safety interlock was opened.

In this event, the OPERATE to STANDBY transition is detected and the measurement conversion used to compute the calibration constant is ignored. The front panel message "IN STBY" is displayed when this occurs.

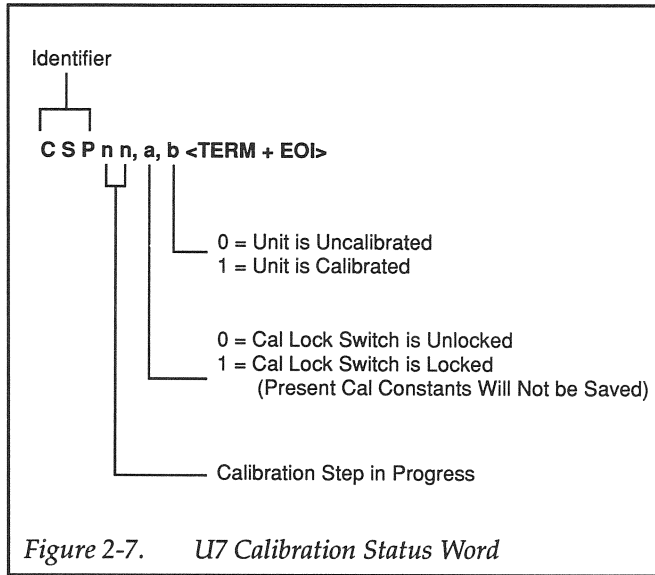

Figure 2-7. U7 Calibration Status Word

2.8 CALIBRATION PROGRAM

The following program can be used to calibrate the Model 236/237. Configure the recommended equipment and software per manufacturers instructions and type in the program.

```

'Rev. C 10/11/90
'*****
'*                               Model 236/237 Calibration Program                               *
'* Equipment Required: Model 193A DMM, Model 263 Calibrator, 10 ohm resistor*
'* 193A address = 10; 236/237 address = 16; 263 address = 8                               *
'* Computer: IBM PC, AT or compatible                                                       *
'* IEEE-488 interface card: IOtech, CEC, or National PC-II or IIA                         *
'* Operating system: PC-DOS or MS-DOS, version 3.0 or later                               *
'* Programming language: Microsoft QuickBASIC version 4.0 or later                         *
'* Bus driver: IOtech Driver488, version 2.3 or later                                       *
'*****
,
CLS
OPTION BASE 1
DIM char(5), char$(5), Ical(8), msg$(4) ' Dimension arrays.
DIM Err$(9)
FOR I = 1 TO 5: READ char$(I): NEXT I ' Read prompt strings.
FOR I = 1 TO 8: READ Ical(I): NEXT I ' Read cal currents.
FOR I = 1 TO 4: READ msg$(I): NEXT I ' Read procedure messages.
FOR I = 1 TO 9: READ Err$(I): NEXT I ' Read error messages.
Dly = 3 ' Measurement delay (seconds).
'***** INITIALIZE IEEE-488 INTERFACE *****
,
OPEN "\DEV\IEEEOUT" FOR OUTPUT AS #1 ' Open IEEE-488 output path.
OPEN "\DEV\IEEEIN" FOR INPUT AS #2 ' Open IEEE-488 input path.
Start: IOCTL #1, "BREAK" ' Reset interface.
PRINT #1, "RESET" ' Warm start interface.
PRINT #1, "REMOTE" ' Assert remote enable.
PRINT #1, "CLEAR" ' Send device clear.
PRINT #1, "TIME OUT 30" ' 30 second bus time out.
PRINT #1, "LOL" ' Enable Local Lockout
CLS ' Clear screen.
LOCATE 12, 20
PRINT " Model 236/237 Calibration Program"
LOCATE 22, 12
PRINT "NOTE: Refer to Service Manual for complete information."
LOCATE 14, 10
GOSUB KeyCheck ' Check for operator signal.
,
'***** SELECT FUNCTION(S) TO CALIBRATE *****
SelCal:
CLS
E = 0: C1 = 0 ' Clear error counter.
PRINT "Select function to calibrate:"
PRINT
FOR I = 1 TO 4 ' Loop for all 4 selections.
PRINT " "; I; "- "; msg$(I); " calibration"
NEXT I
PRINT
InCal: INPUT "Select calibration function (1-4)"; cal
IF cal < 1 OR cal > 4 THEN BEEP: GOTO InCal
IF cal = 1 OR cal = 4 THEN GOSUB TypeCheck ' Get unit type (236 or 237).
PRINT

```

```

'
'***** INITIALIZE 236/237 *****
PRINT #1, "OUTPUT 16;M32,X"      ' 236/237 SRQ on error.
PRINT #1, "OUTPUT 16;B0,,X"    ' Zero bias output level for safety.
PRINT #1, "OUTPUT 16;O0X"      ' Local sensing.
PRINT #1, "OUTPUT 16;K0Y0X"    ' Enable EOI, hold-off, terminator.
'
'***** CHECK CAL LOCK SWITCH STATUS *****
PRINT #1, "OUTPUT 16;U7X"      ' Request calibration status word.
PRINT #1, "ENTER 16"          ' Address 236/237 to talk.
LINE INPUT #2, ST$            ' Input cal status word.
IF MID$(ST$, 7, 1) = "1" THEN ' Check cal lock switch status.
    BEEP
    PRINT "Model 236/237 Cal Lock switch is in locked position."
    PRINT "Calibration will be only temporary."
    PRINT
    C1 = 1
    GOSUB KeyCheck
END IF
'
'***** ENABLE BUS SRQ ERROR TRAPPING *****
'
ON PEN GOSUB ErrCheck          ' Point to error routine.
PEN ON                         ' Enable error detection.
PRINT #1, "ARM SRQ"           ' Enable SRQ.
'
'***** MAIN PROGRAM LOOP *****
'
ON cal GOSUB CalVolt, CalHigh, CalLow
IF cal = 4 THEN
    GOSUB CalVolt
    GOSUB CalHigh
    GOSUB CalLow
END IF
PRINT : BEEP
PRINT #1, "CLEAR"             ' Send DCL.
PRINT msg$(cal); " calibration procedure completed."
PRINT E; "error(s) detected during calibration."
PRINT
IF C1 = 1 THEN PRINT "NOTE: Calibration is temporary."
PRINT
INPUT "Rerun calibration program (y/n)"; IN$
IN$ = LEFT$(IN$, 1)
IF IN$ = "y" OR IN$ = "Y" THEN GOTO SelCal
PRINT #1, "LOCAL"             ' Restore local operation.
CLOSE 1: CLOSE 2              ' Close I/O files.
END                             ' End of program.
'
'*****
' *                VOLTAGE FUNCTION CALIBRATION ROUTINES                *
'*****
'
CalVolt:
CLS

```

```

PRINT "Voltage Calibration Procedure."
PRINT "See Service Manual for details on test connections."
PRINT
PRINT "Short 236/237 output and 193A input."
GOSUB KeyCheck
PRINT #1, "OUTPUT 10;FOROS3G1X"      ' 193A DCV, 6-1/2 digits,auto range.
PRINT #1, "OUTPUT 16;N1X"           ' Put 236/237 in operate.
PRINT #1, "OUTPUT 16;COX"           ' Put 236/237 in cal mode.
PRINT "Performing common mode adjustment."
PRINT "Please wait approximately 30 seconds for completion."
PRINT
PRINT #1, "OUTPUT 16;C1X"           ' Calibrate 236/237 common mode.
PRINT #1, "OUTPUT 10;Z1X"           ' Zero 193A.
BEEP
PRINT #1, "OUTPUT 16;C59X"           ' Remove 236/237 from cal mode
PRINT #1, "OUTPUT 16;NOX"           ' Put 236/237 in standby.
PRINT "Remove short from 236/237 output and 193A input."
PRINT "Make sure 236/237 output is properly connected to 193A input."
PRINT
GOSUB KeyCheck
PRINT #1, "OUTPUT 16;N1X"           ' Put 236/237 in operate.
PRINT #1, "OUTPUT 16;COX"           ' Put 236/237 in cal mode.
PRINT "Performing voltage calibration."
PRINT "Press ESC to abort procedure and restart program."
FOR I = 2 TO Cmax                    ' Loop for all cal points.
IF I = 26 THEN PRINT #1, "OUTPUT 10;R5X" ' Put 193A on 1000V range.
IN$ = INKEY$: IF IN$ = CHR$(27) THEN PRINT #1, "CLEAR": GOTO SelCal
PRINT #1, "OUTPUT 16;C"; I; "X"      ' Send cal command to 236/237.
GOSUB Delay                          ' Wait for settling.
PRINT #1, "ENTER 10"                 ' Get reading from 193A.
INPUT #2, Vmsr                       ' Input 193A reading.
I = I + 1                             ' Increment C command value.
PRINT #1, "OUTPUT 16;C"; I; ",,"; Vmsr; "X" ' Send cal value to 236/237.
NEXT I                                ' Loop back for next cal point.
PRINT #1, "OUTPUT 16;C59X"           ' Exit calibration procedure.
PRINT #1, "OUTPUT 16;NOX"           ' Put 236/237 in standby.
PRINT #1, "OUTPUT 10;ZOR5X"          ' Disable 193A zero mode, 100V range.
RETURN

```

```

'
'*****
' *                               100MA CURRENT RANGE CALIBRATION ROUTINES                               *
'*****
'

```

CalHigh:

CLS

PRINT "100 mA Current Range Calibration."

PRINT "See Service Manual for test connections."

PRINT

GOSUB KeyCheck

PRINT

PRINT #1, "OUTPUT 10;FOROS3G1X" ' 193A DCV, 6-1/2 digits,auto range.

InRes: INPUT "Enter characterized value of 10 ohm resistor"; R10

IF R10 < 9.9 OR R10 > 10.1 THEN BEEP: PRINT "Value out of range.": GOTO InRes

PRINT "Disconnect 236/237 output from test fixture."

```

GOSUB KeyCheck
PRINT #1, "OUTPUT 10;Z1X"          ' Enable 193A zero.
PRINT "Connect 236/237 output to test fixture."
GOSUB KeyCheck
PRINT #1, "OUTPUT 16;N1X"        ' Put 236/237 in operate.
PRINT #1, "OUTPUT 16;COX"        ' Enter cal mode.
PRINT "Performing 100mA range calibration procedure."
PRINT "Press ESC to abort procedure and restart program."
FOR I = 34 TO 41                  ' Loop for all 100mA cal points.
IN$ = INKEY$: IF IN$ = CHR$(27) THEN PRINT #1, "CLEAR": GOTO SelCal
PRINT #1, "OUTPUT 16;C"; I; "X"   ' Send cal command to 236/237.
GOSUB Delay                       ' Settling delay.
PRINT #1, "ENTER 10"             ' Get reading from 193A.
INPUT #2, Vmsr
Imsr = Vmsr / R10                 ' Compute cal current.
I = I + 1                         ' Increment C command value.
PRINT #1, "OUTPUT 16;C"; I; ", "; Imsr; "X" ' Send cal value to 236/237.
NEXT I                            ' Loop back for next cal point.
PRINT #1, "OUTPUT 16;C59X"       ' Exit cal procedure.
PRINT #1, "OUTPUT 16;NOX"        ' Put 236/237 in standby.
PRINT #1, "OUTPUT 10;ZOR5X"      ' Disable 193A zero, 1000V range.
RETURN

```

```

' *****
' *                INA - 10MA CURRENT RANGE CALIBRATION ROUTINES                *
' *****

```

```

Callow:
CLS
PRINT "1nA - 10mA Current Range Calibration."
PRINT "Make sure 263 and 236/237 are properly connected (see Service Manual)."
```

```

PRINT
GOSUB KeyCheck
PRINT #1, "OUTPUT 08;F1ROW1X"    ' 263 amps, auto range, guard on.
' INPUT 263 CHARACTERIZATION PARAMETERS
CharCheck:
INPUT "Enter 263 characterization parameters (y/n)"; IN$
IN$ = LEFT$(IN$, 1)
IF IN$ = "N" OR IN$ = "n" THEN GOTO NoChar
IF IN$ <> "y" AND IN$ <> "Y" THEN BEEP: GOTO CharCheck
PRINT
InChar: PRINT "Enter the following 263 characterization parameters."
PRINT "See Service Manual for 263 characterization procedure."
PRINT
FOR I = 1 TO 5                   ' Loop for all parameters
PRINT "Enter parameter for 263 "; char$(I); " "; ' Prompt for parameter.
INPUT char(I)                    ' Input parameter.
NEXT I                           ' Loop back for next parameter.
NoChar:
FOR I = 1 TO 5
IF char(I) = 0 THEN
    BEEP
    PRINT "Improper characterization parameters are presently entered."
    GOTO InChar

```

```

END IF
NEXT I
PRINT
GOSUB KeyCheck
PRINT "Performing 1nA - 10mA current measurement calibration procedure."
PRINT "Press ESC to abort procedure and restart program."
PRINT #1, "OUTPUT 16;N1X" ' Put 236/237 in operate.
PRINT #1, "OUTPUT 16;COX" ' Put 236/237 in cal mode.
J = 1: K = 1 ' Initialize array index counters.
FOR I = 42 TO 57 ' Loop for all cal points.
  IN$ = INKEY$: IF IN$ = CHR$(27) THEN PRINT #1, "CLEAR": GOTO SelCal
  PRINT #1, "OUTPUT 08;V"; Ical(J); "X" ' Program 263 current value.
  GOSUB Delay ' Allow settling time.
  PRINT #1, "OUTPUT 16;C"; I; "X" ' Send cal offset command to 236/237.
  GOSUB Delay ' Settling time.
  I = I + 1 ' Increment C command value.
  PRINT #1, "OUTPUT 08;O1X" ' Put 263 in operate.
  GOSUB Delay ' Settling time.
  IF I > 47 THEN ' Use characterized values for >100nA
    PRINT #1, "OUTPUT 16;C"; I; ", "; char(K); "X"
    K = K + 1 ' Increment array counter.
  ELSE PRINT #1, "OUTPUT 16;C"; I; ", "; Ical(J); "X"
END IF
GOSUB Delay ' Settling time.
J = J + 1 ' Increment array index.
PRINT #1, "OUTPUT 08;OOX" ' Put 263 in standby.
NEXT I ' Loop back for next cal point.
' 1nA - 10mA SOURCE CALIBRATION
PRINT #1, "OUTPUT 08;F2R1X" ' 263 200mV range.
PRINT #1, "OUTPUT 08;VOX" ' 263 0mV output.
PRINT #1, "OUTPUT 08;O1X" ' Put 263 in operate.
GOSUB Delay
PRINT #1, "TIME OUT 240" ' Select 4 minute bus time out.
PRINT : BEEP
PRINT "Performing 1nA - 10mA source calibration."
PRINT "Please wait approximately 3-4 minutes for completion."
PRINT #1, "OUTPUT 16;C58X" ' Cal 236/237 1nA-10mA source.
PRINT #1, "OUTPUT 16;C59X" ' Exit 236/237 cal mode.
PRINT #1, "OUTPUT 16;NOX" ' Put 236/237 in standby.
PRINT #1, "OUTPUT 08;OOX" ' Put 263 in standby.
PRINT #1, "TIME OUT 30" ' Restore 30 sec. bus time out.
RETURN
'
KeyCheck: ' Check keyboard input routine.
PRINT "Press SPACE or ENTER key to continue (ESC to end program)."
PRINT
Lp1: IN$ = INKEY$: IF IN$ <> "" THEN GOTO Lp1
Lp3: IN$ = INKEY$: IF IN$ = "" THEN GOTO Lp3
IF IN$ = CHR$(27) THEN ' Check for ESC.
  CLS
  PRINT "Program terminated"
  PRINT #1, "CLEAR" ' Send DCL.
  PRINT #1, "ABORT" ' Send IFC.
  PRINT #1, "LOCAL" ' Restore local operation.

```

```

        CLOSE 1
        CLOSE 2
        END
END IF
IF IN$ <> CHR$(32) AND IN$ <> CHR$(13) THEN BEEP: GOTO Lp1
RETURN
'
Delay:                                     ' Delay subroutine
t = TIMER
Lp2: IF (TIMER - t) < Dly THEN GOTO Lp2
RETURN
'
ErrCheck:                                  ' Error check subroutine.
IF IOCTL$(2) <> "0" THEN RETURN           ' Driver ready for command?
PRINT #1, "SPOLL"                          ' Check for non-SRQ interrupt.
INPUT #2, SB
IF SB = 0 THEN RETURN
PRINT #1, "SPOLL 16"                        ' Serial poll 236/237.
INPUT #2, SB                                ' Input serial poll byte.
IF (SB AND 32) <> 0 THEN                   ' Check for error.
    E = E + 1                               ' Increment error counter.
    BEEP
    PRINT #1, "OUTPUT 16;U1X"               ' Request error word.
    PRINT #1, "ENTER 16"
    INPUT #2, Err$                           ' Input error word.
    PRINT
    GOSUB CalStep
    PRINT "Model 236/237 ";
    GOSUB DispErr
    PRINT " Error on calibration step #"; ST; "."
    PRINT "See calibration error message list in Service Manual."
    PRINT
    GOSUB KeyCheck
    PRINT "Continuing..."
END IF
RETURN
'
DispErr:                                    ' Display error subroutine.
IF MID$(Err$, 7, 1) = "1" THEN PRINT "Interlock Present";
IF MID$(Err$, 14, 1) = "1" THEN PRINT "In Standby";
IF MID$(Err$, 13, 1) = "1" THEN PRINT "In Calibration";
FOR L = 1 TO 9                              ' Check cal error messages.
IF MID$(Err$, L + 20, 1) = "1" THEN PRINT Err$(L);
NEXT L
RETURN
'
TypeCheck:                                  ' Check if unit is a 236 or 237.
PRINT #1, "OUTPUT 16;UOX"                  ' Request model number status.
PRINT #1, "ENTER 16"                       ' Address 236/237 to talk.
INPUT #2, ST$                               ' Input model number status string.
IF LEFT$(ST$, 3) = "236" THEN              ' Compute last voltage cal C
    Cmax = 25                               ' command value based on whether
ELSE                                         ' unit is a 236 or a 237.
    Cmax = 33

```



```

END IF
RETURN
'
CalStep:                                ' Determine cal step for cal error.
PRINT #1, "OUTPUT 16;U7X"                ' Request cal status word.
PRINT #1, "ENTER 16"                     ' Address 236 to talk.
LINE INPUT #2, ST$                        ' Input cal status word.
ST = VAL(MID$(ST$, 4, 2))                 ' Convert step to variable.
RETURN
'
' Characterization prompt strings
DATA "2uA range (approx. 0.9uA)"
DATA "20uA range (approx. 9uA)"
DATA "200uA range (approx. 90uA)"
DATA "2mA range (approx. 0.9mA)"
DATA "20mA range (approx. 9mA)"
'
' Current calibration data
DATA 0.9E-9,9E-9,90E-9,0.9E-6,9E-6,90E-6,0.9E-3,9E-3
' Procedure message data strings
DATA "Voltage","100 mA current range"
DATA "1nA to 10mA current ranges","Complete Model 236/237"
'
' Error message strings.
DATA "Cal ADC Zero","Cal ADC Gain","Cal SRC Zero","Cal SRC Gain"
DATA "Cal Common Mode","Cal Compliance","Cal Value"
DATA "Cal Constants","Cal Invalid"

```

SECTION 3

Maintenance

3.1 INTRODUCTION

This section contains information necessary to maintain and troubleshoot the Model 236/237.

WARNING

Other than line fuse replacement and fan filter cleaning, the procedures included in this section are for use only by qualified service personnel. Do not perform these procedures unless qualified to do so. Troubleshooting steps may expose you to potentially lethal voltages that could result in injury or death if normal safety precautions are not observed.

3.2 LINE FUSE REPLACEMENT

A rear panel fuse located adjacent to the line voltage switch (see Figure 3-1) protects the power line input of the Source Measure Unit. If the fuse needs to be replaced (line voltage switch setting changed or suspected blown fuse), perform the following steps:

WARNING

Make sure the Source Measure Unit is disconnected from the power line and other equipment before replacing the fuse.

1. With the power off, place the end of a flat-blade screwdriver into the slot in the rear panel line LINE FUSE holder. Push in gently and rotate the fuse carrier one-quarter turn counterclockwise. Release pressure on the holder and its internal spring will push the fuse and carrier out of the holder.
2. Remove the fuse and replace it with the type recommended in Table 3-1.

CAUTION

Do not use a fuse with a higher current rating than specified, or instrument damage may occur. If the instrument repeatedly blows

fuses, locate and correct the cause of the trouble before replacing the fuse. See paragraph 3.8 for troubleshooting information.

3. Install the new fuse and the fuse carrier into the holder by reversing the above procedure.

Table 3-1. Line Fuse Selection

Line Voltage	Fuse Type	Keithley Part Number
195-250V	1/2A, 250V, 3AG, Slo Blo	FU-4
90-125V	1A, 250V, 3AG, Slo Blo	FU-10

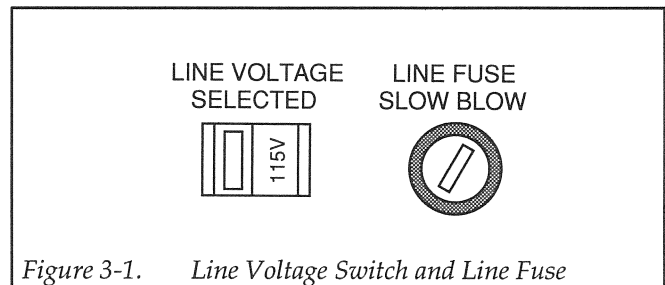

Figure 3-1. Line Voltage Switch and Line Fuse

3.3 FAN FILTER CLEANING

The Model 236/237 has an internal cooling fan to vent heat out of the instrument case. The fan has a filter to keep dirt and dust from entering the instrument case. Contamination on pc boards could result in degraded performance. The fan filter must be cleaned periodically to maintain internal cleanliness and proper ventilation.

Perform the following steps to remove and clean the fan filter element:

1. Turn off the Model 236/237. The fan must be off in order to prevent dirt and dust from being ingested

into the instrument case while removing the filter element.

2. Position the instrument such that you are facing the rear panel. The cooling fan is internally mounted to the right-hand end of the rear panel. The filter assembly is mounted to the rear panel in front of the fan intake vents.
3. Remove the two screws that secure the vented shroud of the filter assembly to the rear panel. The filter assembly will swing away from the rear panel allowing the filter element to be removed.
4. To clean the filter element, blow out the dust and dirt with pressurized air or nitrogen.
5. Reinstall the filter assembly onto the rear panel. The two hinges of the filter assembly shroud fit into the rear panel vents. Make sure the filter element covers all the rear panel intake vents.

NOTE

If the fan filter on your unit is installed inside the instrument case, you will have to remove the top and bottom covers in order to gain access to the filter element (see Disassembly, paragraph 3.6). The filter can be mounted to the outside of the rear panel by ordering the shroud (Keithley p/n 236-332).

3.4 BATTERY REPLACEMENT

When line power to the Model 236/237 is turned off, the lithium battery on the digital board provides backup power to the memory in which user programmed setup conditions and sweep data are stored. The battery has enough capacity to maintain data for one year of continuous power off, or two years if the Model 236/237 is on for 12 hours every day. The battery by itself has a shelf life of eight years. Although the Model 236/237 will operate without a battery, it will not retain any setup conditions or sweep data when turned off. The instrument will power up to the factory default conditions.

The battery may be replaced with any 2450 lithium coin cell. It can also be ordered from Keithley (part number BA-44).

Replacement of the lithium battery is normally a safe procedure as long as these safety precautions are followed.

WARNING

The precautions below must be followed to avoid possible personal injury.

1. Do not short the battery terminals together.
2. Do not incinerate or otherwise expose to excessive heat (>60°C).
3. Keep lithium batteries away from all liquids.
4. Do not recharge lithium batteries.
5. Observe proper polarity when inserting battery into holder.

Replace the battery as follows:

1. Turn off the power, disconnect the line cord, and remove all test leads.
2. After allowing at least three minutes for internal capacitors to discharge, remove the top cover (see paragraph 3.6).
3. The battery is on the digital board (see Figure 3-2 for location). Pry the battery out of its holder using a non-metallic tool.

WARNING

Do not use a metal tool to pry out the battery as you could short the terminals.

4. Install the new battery, taking care to observe proper polarity as stamped on the battery holder. The plus (+) terminal of the battery faces up.
5. Reinstall the top cover.

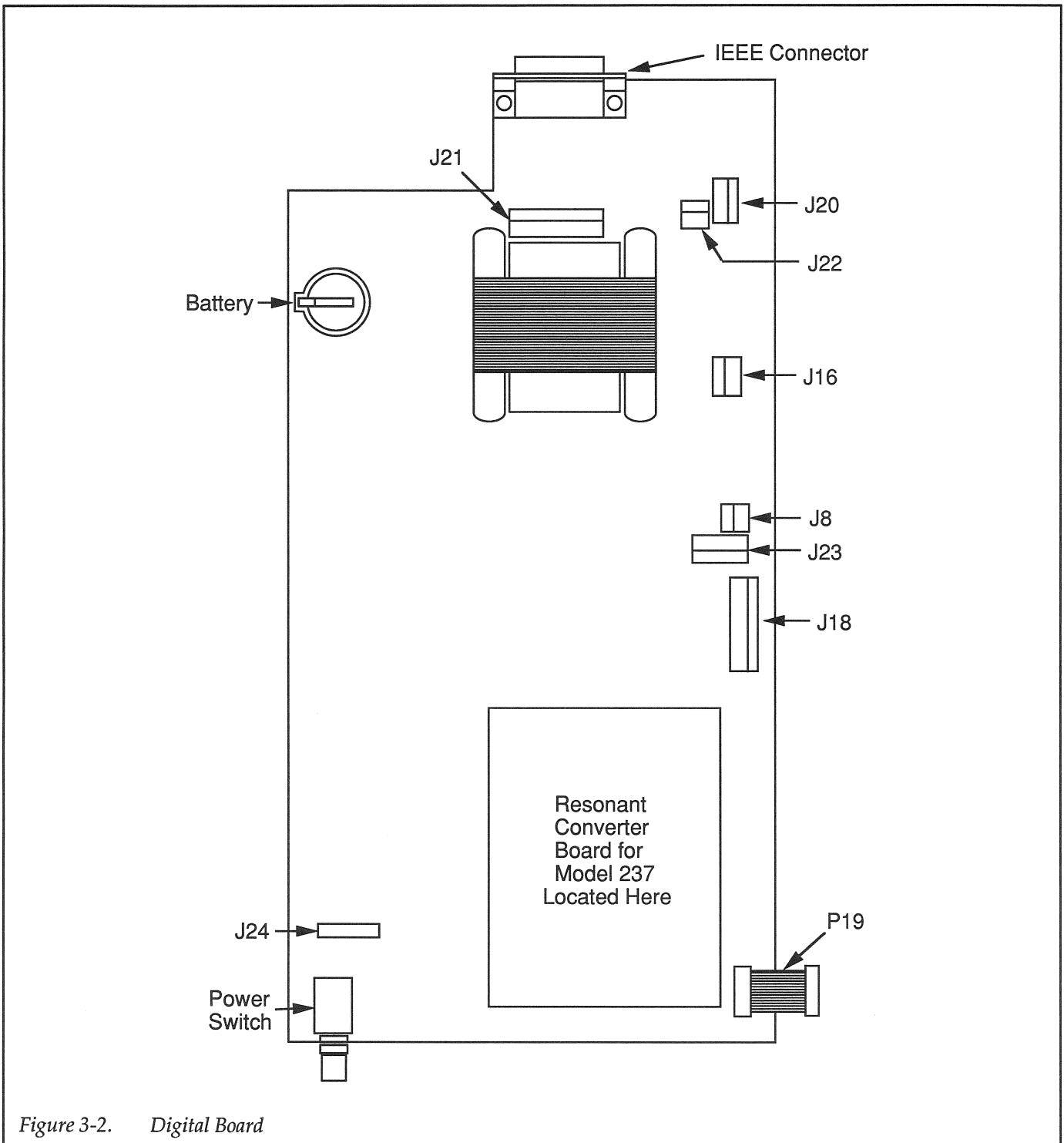

Figure 3-2. Digital Board

3.5 HANDLING AND CLEANING PRECAUTIONS

When troubleshooting or otherwise working inside the instrument, care should be taken not to indiscriminately touch PC board traces and open wires to avoid contaminating them with body oils or other foreign matter. Areas covered by a shield within the Model 236/237 have high impedance devices or sensitive circuitry where contamination could cause degraded performance.

The same general precautions apply when replacing parts in these areas. When unsoldering and soldering parts, be careful not to spread the flux around the board to adjacent areas.

1. Using a squeeze bottle, carefully apply clean, uncontaminated methanol to the area to be cleaned. Use sufficient solution to thoroughly wet the circuit board.
2. Using a small, clean brush, wipe the area thoroughly until it is free of flux or contaminants. In some cases, it may be helpful to tilt the board at an angle and brush contaminants away from the affected area, allowing contaminated residue and methanol to run off the board.
3. Wash the area again with fresh, clean methanol, allowing it to drain, flushing contaminants off the board.
4. Once the area is thoroughly cleaned, it should be dried with pressurized dry clean air or nitrogen. Do not use compressed air from an ordinary air compressor, as oil particles in the air could contaminate the circuit board.
5. After cleaning or parts replacement, check to see that any components connected to the Teflon® insulators are not physically touching the board or adjacent parts.

3.6 DISASSEMBLY INSTRUCTIONS

If it is necessary to troubleshoot the instrument or to replace a component, use the following disassembly procedure. Disassembly should be done in the order that it is presented since many steps depend on a previously performed procedure. Procedures pertaining to the Model 237 should be ignored if servicing a Model 236. Refer to Figures 3-2 through 3-6.

NOTE

Connector designations on the illustrations use either a "P" or "J" prefix. A "P" indicates that the connector is a plug type, while "J" indicates that it is a receptacle. For example, P10 is a plug connector that mates to receptacle J10.

WARNING

Disconnect the line cord and any test leads from the instrument, and wait at least three minutes to allow high voltage capacitors to discharge before beginning disassembly.

1. Remove the top cover as follows:
 - A. The top cover is secured to the chassis by six screws. Four are located at the top of the instrument and two are located at the rear. Remove those six screws.
 - B. Slide the top cover towards the rear of the instrument until it separates completely from the chassis.
2. Remove the bottom cover as follows:
 - A. If installed, remove the four plastic feet located on the bottom cover. Each foot is secured with a single screw.

CAUTION

To prevent damage to unit or internal circuit boards, use #6-32 × 1/4" long Phillips pan head screws provided in kit to secure bottom cover after removal of feet.

- B. The bottom cover is secured to the chassis by two screws located at the rear of the instrument. Remove those two screws.
- C. Slide the bottom cover towards the rear until it completely separates from the chassis.

CAUTION

When reinstalling the bottom cover, use the proper screws to install the four feet. Screws that are too long will cause damage to the internal circuit boards. The front feet are secured by #6-32 × 5/8" screws, and the rear feet are secured by #6-32 × 1/2" screws.

If leaving the feet off in order to install the instrument in a rack, do not use the original screws to secure the bottom cover. Instead, use the four short screws (#6-32 × 1/4") supplied with the rack mount kit.

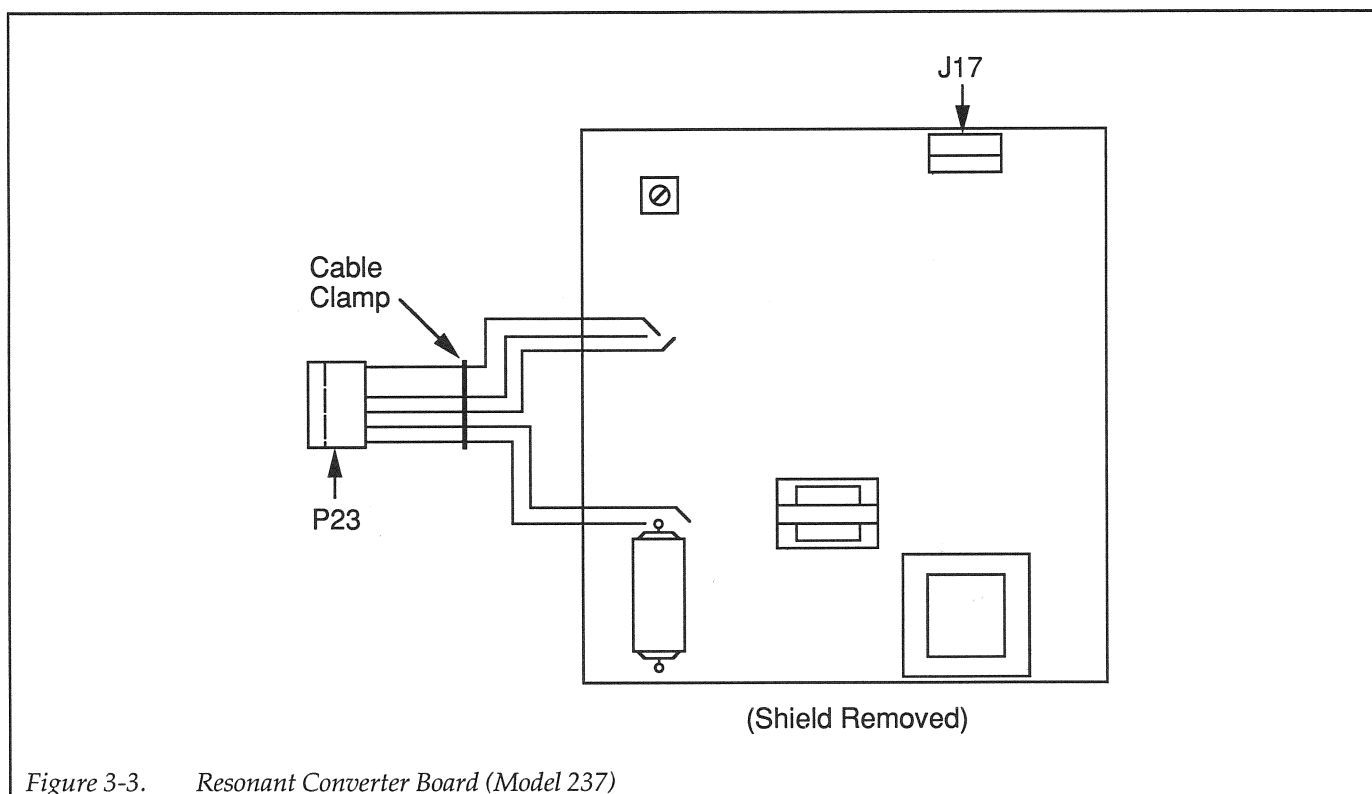

Figure 3-3. Resonant Converter Board (Model 237)

3. If the cooling fan needs to be removed, proceed as follows. Otherwise, proceed to step 4.
 - A. Disconnect P22 (fan) from J22 on the digital board (see Figure 3-2).
 - B. Disconnect the ground wire from the rear panel.
 - C. Remove the four fasteners that secure the fan to the rear panel.
 - D. Pull the fan out of the instrument case.
4. For the Model 237, remove the resonant converter board (see Figure 3-3) as follows:

Note: The resonant converter board is mounted on the digital board. Figure 3-2 indicates the location of the resonant converter board.

- A. Remove the shield that covers the resonant converter board. It is secured with four screws.
- B. Disconnect P17 from J17, and disconnect P23 from J23 which is located on the digital board (see Figure 3-2).
- C. Carefully lift the resonant converter board out of the instrument case.

Note: When reinstalling the resonant converter board, make sure the two cable clamps, which protect the wires, are installed in the slots of the shield.

5. Remove the output board (see Figure 3-4) as follows:

Note: The output board is mounted on the analog board adjacent to the rear panel.

WARNING

To avoid burns from excessive heat, make sure that the heat sink on the output board is cool enough to handle. If the heat sink is hot, wait until it is cool before attempting to remove the output board.

- A. Disconnect P16 from J16 on the digital board (see Figure 3-2).
- B. Remove the four screws that secure the output board assembly to the analog board.
- C. Grasp the heat sink and lift up the output board assembly a few inches. Disconnect P15 from J15 which is located on the analog board directly under the output board.
- D. Lift the output board out of the instrument case.

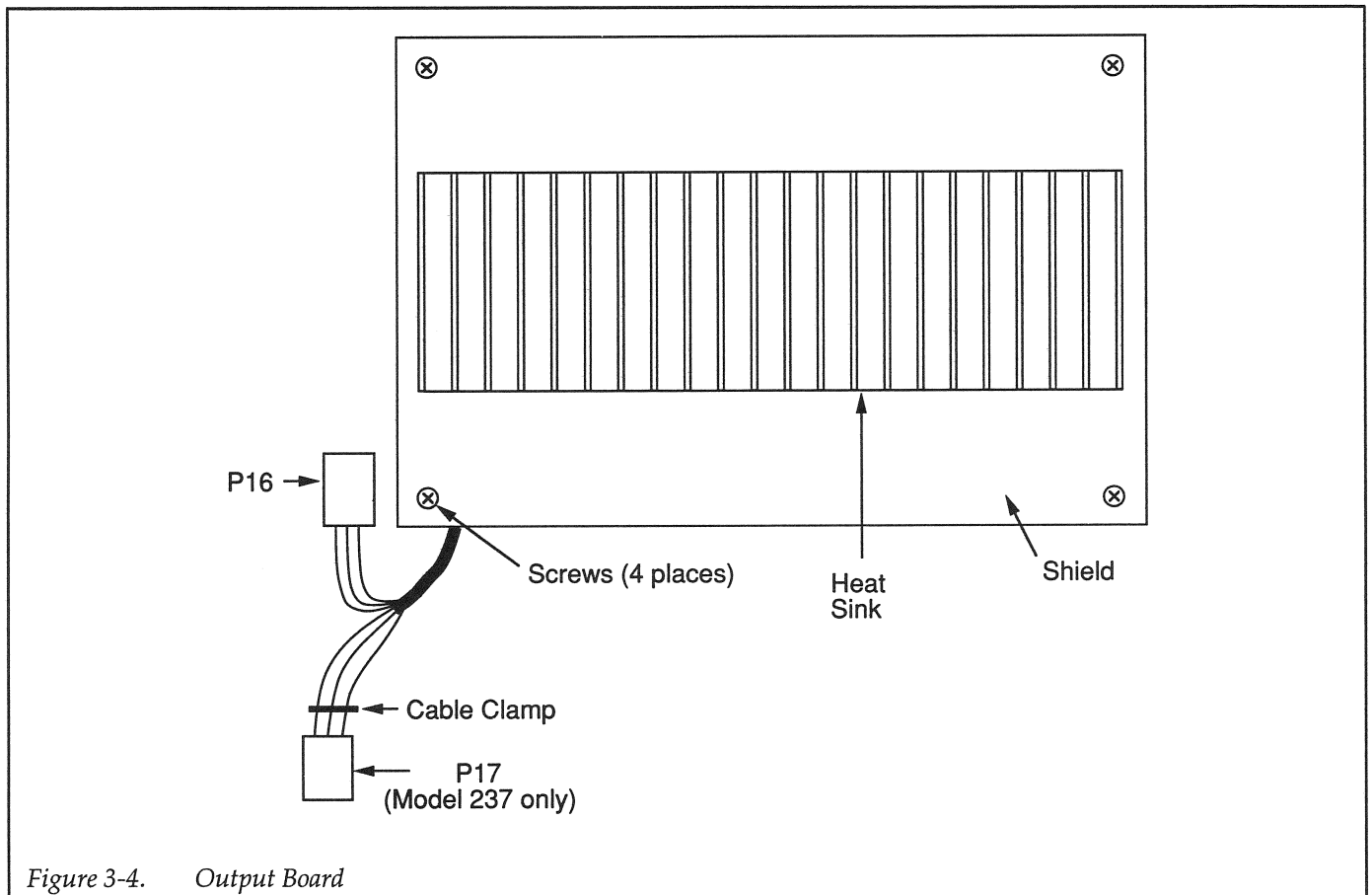

Figure 3-4. Output Board

6. Remove the analog board (see Figure 3-5) as follows:
 - A. Remove the analog board shield. It is secured to the analog board with four screws.
 - B. Remove the inner shield. It is secured to the analog board with three screws.
 - C. Disconnect P19 (ribbon cable from digital board) from J19.
 - D. Disconnect P8 and P18 from J8 and J18 on the digital board.
 - E. Disconnect the berg pin connector for the OUTPUT LO banana jack from J27.
 - F. Disconnect the SMB triax connectors from J11, J12 and J13.
 - G. Place the instrument on its right side and, from the case bottom, remove the seven screws that secure the analog board to the mounting rails.
 - H. Place the instrument in the normal upright position and carefully manipulate the analog board assembly out of the instrument case.
 - I. Remove the bottom shield of the analog board. It is secured to the analog board by the five remaining screws accessible from the component side of the board.

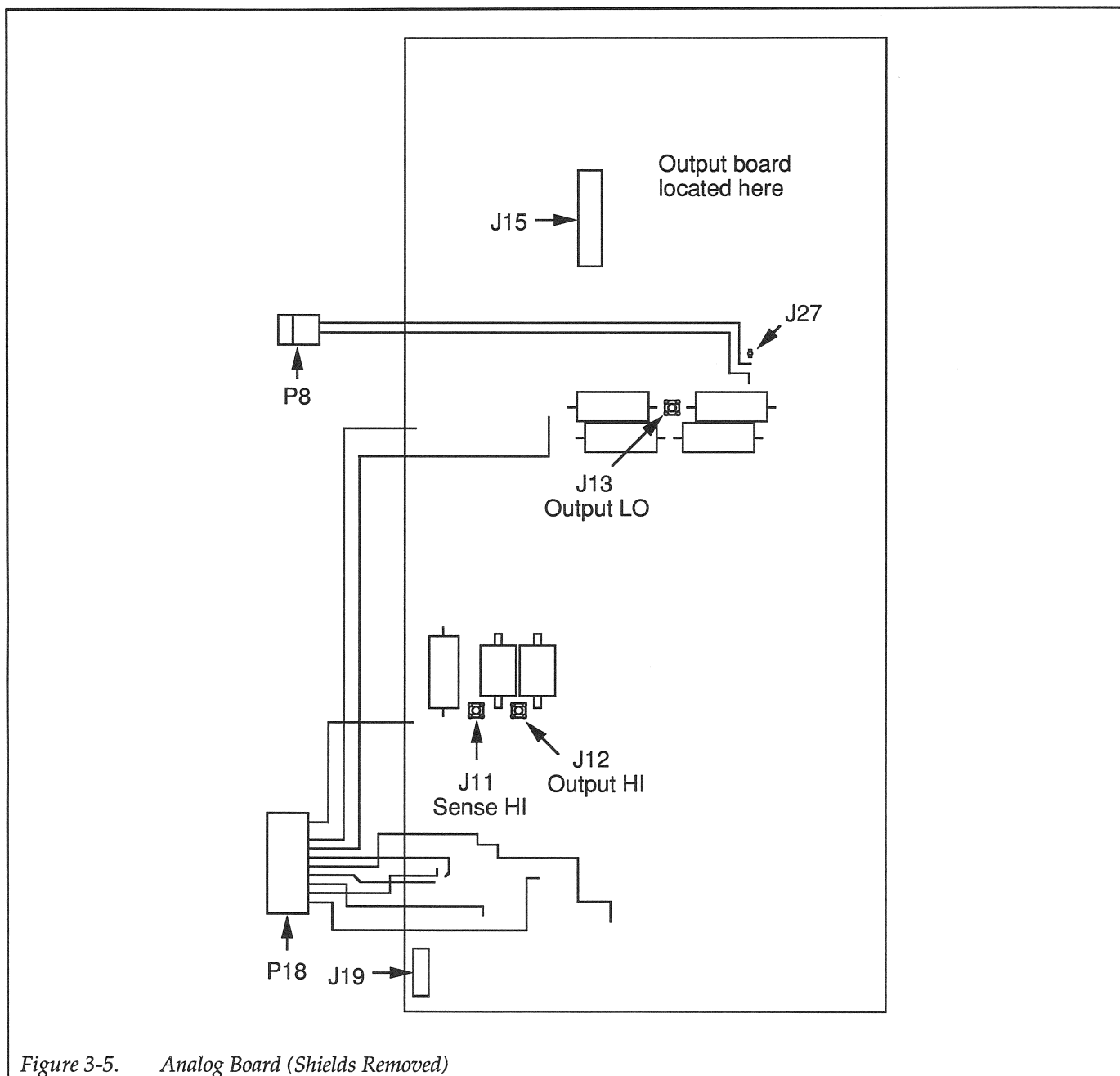

Figure 3-5. Analog Board (Shields Removed)

7. Remove the rear panel assembly as follows:
 - A. Disconnect P20 (ac line filter) and P22 (fan) from J20 and J22 on the digital board.
 - B. At the back of the instrument, remove the two nuts that secure the IEEE-488 interface connector to the rear panel.
 - C. Remove the four screws that attach the rear panel to the side panels of the instrument. Two of these screws also secure the fan filter assembly to the rear panel.
 - D. To provide clearance, pull the rear panel outward a little and then disconnect P21 (Trigger

- and Interlock) from J21 on the digital board.
- E. Separate the rear panel from the instrument case.

WARNING

To provide protection from possible electric shock, when re-assembling make sure the ground wires from the ac power outlet and cooling fan are connected to the rear panel.

8. Remove the digital board (see Figure 3-2) as follows:

- A. Disconnect the display board ribbon cable from J24.
 - B. Place the instrument on its left side. From the bottom of the instrument case, notice that there are eight screws (seven slotted and one Phillips) securing the digital board to the three mounting rails. The Phillips head screw installs into a kep nut on the other side of the board. Remove this screw first and make sure not to lose the kep nut.
 - C. Remove the other seven screws that secure the digital board to the mounting rails. Be sure not to let the digital board fall when the last screw is removed.
 - D. Place the the instrument in the normal upright position and remove the digital board from the case.
 - E. Remove the top and bottom shield for the digital board. This shield assembly is secured to the board by four screws. Note that on the Model 237, the bottom shield for the resonant converter must first be removed. This shield is also secured to the digital board with four screws.
9. Remove the display board as follows:
- A. At the front panel, pull off the rotary knob.
 - B. Remove each of the four decorative strips from the side panels as follows:
 - a. From inside the case, place a thin blade screwdriver into one of the holes where the decorative strip is secured.
 - b. Carefully push outwards until the strip disengages from one of the fasteners.
 - c. Pull the strip away from the side panel.
- Note: To reinstall, align the strip in the recessed part of the side panel and press the strip at the locations of the fasteners.
- C. Remove the four screws that secure the front panel assembly to the side panels and disengage the front panel assembly from the chassis.
 - D. Loosen the four Allen set screws securing the bezel assemblies to the front panel. Remove the bezel assemblies from the front panel.
 - E. Lift the display board away from front panel.
10. The instrument can be re-assembled by reversing the above procedure. Make sure that all parts are properly seated and secured, and that all connections are properly made. To ensure proper operation, shields must be replaced and fastened securely.

CAUTION

To prevent damage to unit or internal circuit boards, use #6-32 × 1/4" long Phillips pan head screws provided in kit to secure bottom cover after removal of feet.

WARNING

To ensure continued protection against safety hazards, verify that power line ground (green wire attached to ac power receptacle) and fan ground are connected to the rear panel.

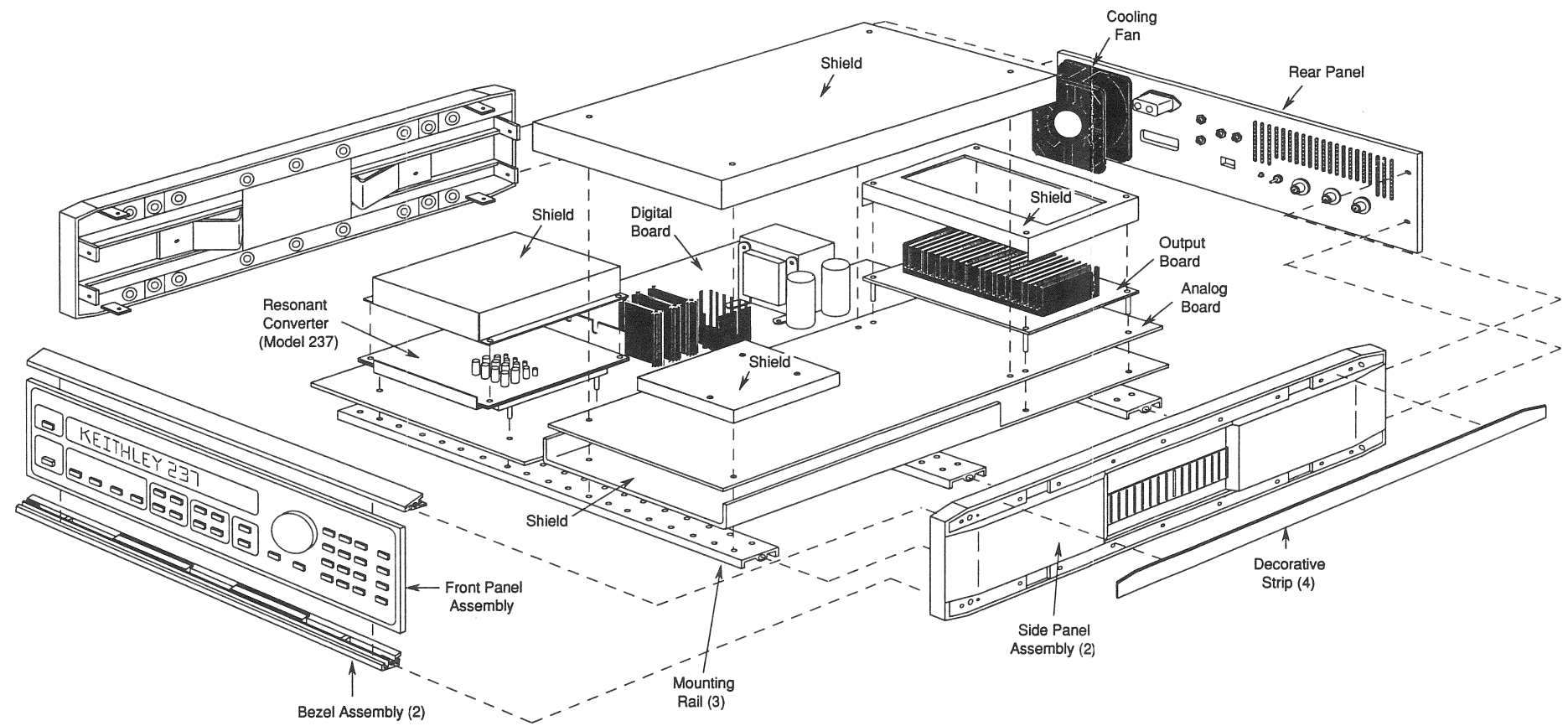

Figure 3-6. Model 237 Exploded View

3.7 SPECIAL HANDLING OF STATIC SENSITIVE DEVICES

CMOS devices operate at very high impedance levels for low power consumption. As a result, any static that builds up on your person or clothing may be sufficient to destroy these devices, if they are not handled properly. Use the following precautions to avoid damaging them.

1. ICs should be transported and handled only in containers specially designed to prevent static build-up. Typically, these parts will be received in anti-static containers of plastic or foam. Keep these devices in their original containers until ready for installation.
2. Remove the devices from their protective containers only at a properly grounded work station. Also, ground yourself with a suitable wrist strap.
3. Handle the devices only by the body; do not touch the pins.
4. Any printed circuit board into which the device is to be inserted must also be grounded to the bench or table.
5. Use only anti-static type solder sucker.
6. Use only grounded tip solder irons.
7. Once the device is installed in the PC board, it is normally adequately protected, and normal handling can resume.

3.8 TROUBLESHOOTING

The troubleshooting information contained in this section is intended for use by qualified personnel having a basic understanding of analog and digital circuitry. The individual should also be experienced at using typical test equipment as well as ordinary troubleshooting procedures. The information presented here has been written to assist in isolating a defective circuit or circuit section. Isolation of a specific component is left to the technician. Note that schematic diagrams and component location drawings, which are an essential aid to troubleshooting, are included in Section 5.

3.8.1 Recommended Test Equipment

Success in troubleshooting complex equipment like the Model 236/237 depends not only on the skill of the technician, but relies on the use of accurate, reliable test equipment. Table 3-2 lists the equipment recommended for troubleshooting the Model 236/237. Other equip-

ment, such as logic analyzers and capacitance checkers, could also be helpful.

Table 3-2. Recommended Troubleshooting Equipment

Equipment	Use
Five function DMM with 0.1% basic dcV accuracy, 10M input impedance	Power supply and dc voltage checks; analog signal tracing continuity, logic levels.
Dual-trace, triggered sweep oscilloscope, dc to 50MHz	Digital and analog waveform checks.
Digital frequency counter	Checking clock frequencies.

3.8.2 Diagnostics

The Model 236/237 has some internal diagnostic capabilities to aid in troubleshooting.

Power-up and MEMORY TEST

On power-up or when the Memory Test is run, the Model 236/237 performs a series of tests on its memory elements. If a failure occurs, one or more front panel messages are displayed.

Perform the following steps to perform the Memory Test:

1. Enable MENU and use the rotary knob to display "MEMORY TEST".
2. Press ENTER. If the test passes, the display will blank for a couple of seconds and display the next menu item. Otherwise, a failure will cause one or more front panel messages to be displayed.

Note: The Memory Test can also be run by sending J1X over the bus.

The front panel messages associated with memory element failures are explained as follows.

Message	Explanation
CAL INVALID ERR	On power-up, this message will indicate that one or more calibration errors exist. The Model 236/237 needs to be re-calibrated.
CAL CONSTANTS ERR	One or more calibration constants are not within allowable limits. Default cal constants will be used. Try re-calibrating the Model 236/237. Repeated failures may indicate defective E ² ROM (U33).
IOU CAL CHECKSUM	Checksum test of calibration constants failed. Try re-calibrating the instrument. Repeated failures may indicate a defective E ² ROM (U33).
UNCALIBRATED	There are no calibration constants stored in memory. The E ² ROM (U33) may be defective. Note that the Source Measure indicator light blinks.
IOU DPRAM FAILED	The dual-port RAM for the I/O controller has failed making the instrument non-functional. The DPRAM (U12) may be defective.
IOU EEROM FAILED	The E ² ROM (U33) in the I/O controller has failed making the instrument non-functional.
DPRAM LOCKUP	The source/measure controller cannot respond to the I/O controller due to RAM (U13), EPROM (U17), or microprocessor (U25) failure. The instrument is non-functional.
DPRAM LINK ERR	Communications error in the DPRAM (U12) between the I/O controller and the source/measure controller. The unit is non-functional.
1F	IOU RAM (U30) failure. Unit is non-functional.
2F	IOU EPROM (U31) failure. Unit is non-functional.

Note: There are error messages associated with calibration and are covered in the calibration section of this manual.

Display Test

When the display test is run all display segments and front panel indicator lights are turned on for a few seconds. Perform the following steps to run the display test:

1. Enable MENU and use the rotary knob to display "DISPLAY TEST".
2. Press ENTER to run the test.

Note: The memory test can also be performed by sending J2X over the bus.

A/D Test Mode

The instrument can be placed in the A/D test mode which allows the A/D multiplexer (U1) to be stopped in any one of its A/D phases. This allows switching states to be checked and signal tracing to the A/D input (see A/D Multiplexing in paragraph 3.8.5).

1. Turn off the Model 236/237.
2. While holding in the MENU button, turn on the Model 236/237. Continue to hold in the MENU button until the MENU indicator turns on.
3. Use the rotary knob to display "A/D TEST". Note that the A/D converter is still running normally at this time.
4. Press ENTER. The following message will be briefly displayed:

ENTER TO EXIT

This is an instructional message indicating that once in the A/D test mode, pressing ENTER will exit the test mode allowing the A/D converter to run normally. The following message will then be displayed:

A/D ZERO TEST

This message indicates that the A/D converter is locked in the zero phase.

5. The instrument can be placed in any of the other A/D phases (A/D REF, A/D VOLTS and A/D AMPS) with the use of the SELECT buttons.
6. To exit from the A/D test mode, press ENTER.
7. To return the instrument to the normal source/measure display state, press MENU.

Note: The A/D test will remain on the MENU until power is cycled.

3.8.3 Power Supply Checks

Table 3-3 shows the various checks that can be made to the power supplies of the Model 236/237. In addition to the normal voltage checks, it is a good idea to check the various supplies with an oscilloscope for signs of noise or oscillations.

Table 3-3. Power Supply Checks

Step	Item	Component	Required Condition	Remarks
1	Line voltage switch	—	Set to 115V or 230V as required.	Line voltage selection.
2	Line fuse	—	Check for continuity	Remove fuse to check.
3	Line power	—	Plugged into live receptacle; power on	
4	+5V Digital supply	VR1, pin 2	+5V \pm 0.25%	Reference to digital common.
5	\pm 15V Analog supplies	VR3, pin 3 VR4, pin 3	+15V, \pm 1V -15V, \pm 1V	Reference to floating common.
6	\pm 30V Analog supplies	VR5, pin 2 VR6, pin 3	+30V, \pm 2V -30V, \pm 2V	Reference to floating common.
7	+5V Analog supply	VR2, pin 3	+5V, \pm 0.25%	Reference to floating common.
8	\pm 150V Floating supply	J16, pin 4 J16, pin 1	+150V, \pm 20V -150V, \pm 20V	Reference to output common.
9	\pm 15V Floating supply	J8, pin 1 J8, pin 2	+15V, \pm 1V +15V, \pm 1V	Referenced to output common.
10	+50V Isolated supply	J23, pin 2	+50V, \pm 10V	Referenced to output common.

3.8.4 Analog Control Lines

Control lines, managed by the source/measure controller, are used to drive the various relays, switching FETs and analog switches associated with analog circuitry operation. That is, an appropriate voltage level present on a control line will cause the respective switch to close or open.

These control lines (located on schematic 236-126, page 1) drive relay coils, gates of switching FETs, and inputs of analog switches. The following summarizes the nominal voltage levels that should be present on the control lines to drive these switching devices.

NOTE

To check voltage levels on control lines, reference the measurement to floating common.

CAUTION

On the Model 236/237, remove the ground link from output common when using chassis grounded equipment to make measurements referenced to floating ground. Otherwise, erroneous measurements or possible instrument damage may result.

Relay Drive

K8, K9, K10, K11 and K12;
0V = relay switch closed
+5V = relay switch open

K1, K3, K4, K5, K6, K7 and K15;
0V = relay switch open
+5V = relay switch closed

FET Switch Drive

N-channel FET;
0V = switch closed (on)
-15V = switch open (off)

P-channel FET;
0V = switch closed (on)
+15V = switch open (off)

Analog Switch Drive (U45, U48 and U49)

0V = switch closed

+5V = switch open

Other control lines that are not used to drive switching devices are described as follows:

COMPLIANCE — Used for compliance detection. When the Model 236/237 is in compliance, this control line is at 0V. Otherwise, +5V is on this line.

POLARITY — Used to provide the appropriate 10V reference for the clamping circuits. When the instrument is programmed for a positive (+) output, this control line is at nominally +10V. When programmed for a negative (-) output, this line is at nominally -10V.

100mA RANGE BIAS — Used to select the appropriate current limit to the output stage. With the instrument on the 100mA range (source or measure), this control line is at +5V. On the other current ranges this line is at 0V.

3.8.5 Analog Switching

Tables 3-3 through 3-8 provide the switching states of most of the analog circuit switching devices for the various operating conditions.

Current Ranging — Table 3-4 lists the switches that are closed for each of the nine current ranges. This table applies to both source and measure current ranges. Notice that on the 1nA range none of the current range relays are closed.

Table 3-4. Analog Switching; Current Ranging

Range	Relays Closed	Range Switches Closed
100mA	K8	Q5-Q9, Q37, Q38
10mA	K9	U45A, Q10, Q11
1mA	K9	U45A, Q12, Q13
100µA	K9	U45A, Q4, Q14
10µA	K9	U45A, Q4
1µA	K10	U45A, Q4
100nA	K11	U45A, Q4
10nA	K12	U45A, Q4
1nA	—	U45A, Q4

Volts Ranging — Table 3-5 lists the switches that are closed for each of the available voltage ranges. This table applies to both source and measure voltage ranges.

Table 3-5. Analog Switching; Volts Ranging

Range	Relays Closed	FET Switches Closed
1.1V	K4, K6, K7	Q24, Q33, Q35
11V	K4, K6, K7	Q24
110V	K7	—
1100V	—	—

Feedback — As listed in Table 3-6, analog switches U48 and U49 are used for feedback switching. Each of these two devices has four individual switches and are identified by their circuit schematic pin numbers. The table lists the states of these switches for standby and operate conditions while programmed to source current and voltage.

Sensing — As listed in Table 3-7, three relays are used to select local or remote sensing. Note that when the instrument is programmed for remote sensing, the relay switches will default to the local sensing states when placed in standby. That is, relay K3 will open, and relays

K15 and K5 will close whenever the instrument is placed in standby.

Table 3-7. Analog Switching; Sensing

Sense	Relays*		
	K3	K15	K5
Local	Open	Closed	Closed
Remote	Closed	Open	Open

*Relay states with 236/237 in OPERATE. In standby, relays go to local sense states.

Output — For safety, there are two relays that are used to disconnect OUTPUT HI and SENSE HI from the rear panel output triax connectors. When the instrument is off, relays K1 and K2 are open. When turned on, these relay switches remain open until the instrument is first placed in operate. These two switches then remain closed while the instrument is powered on.

A/D Multiplexing — During normal operation, the A/D multiplexer (U1) continuously applies a sequence of signals to the input of the A/D converter. These signals include Zero, Reference and Measure (I or V). Only one signal is switched to the A/D input at one time. The switching speed and sequence varies according to how the instrument is programmed to operate.

In the A/D test mode (see paragraph 3.8.2) the A/D converter is locked up in the desired A/D phase. This allows

Table 3-6. Analog Switching; Feedback

Analog Switches		Source I Measure V		Source V Measure I	
Device	Pins	Standby	Operate	Standby	Operate
U48	6, 7	Closed	Open	Closed	Closed
U49	6, 7	Closed	Open	Closed	Closed
U48	2, 3	Closed	Open	Closed	Closed
U49	10, 11	Closed	Open	Closed	Closed
U48	10, 11	Open	Closed	Open	Open
U49	14, 15	Open	Closed	Open	Open
U48	14, 15	Open	Closed	Open	Open
U49	2, 3	Open	Closed	Open	Open

multiplexer switch states to be checked and signal tracing to the A/D input to be performed. Table 3-8 identifies the switch that is closed during each A/D phase. The pin numbers of multiplexer U1 are used to identify each switch.

Table 3-8. Analog Switching; A/D Multiplexing

A/D Phase	U1 Switch Closed (pins)
Reference	6, 7
V Measure	14, 15
I Measure	10, 11
Zero	2, 3

3.8.6 Digital and Display Checks

The digital and display circuitry can be checked out by using the troubleshooting data found in Tables 3-9 and 3-10.

Note: The firmware that controls the Model 236/237 is contained in two EPROMs (U17 and U31). If it is necessary to replace one or both of the EPROMs, make sure that both EPROMs installed in the instrument have the same firmware revision level. After installing new firmware, perform factory initialization to write firmware changes to the E²ROM. Factory initialization is performed by enabling MENU, displaying FACTORY INIT with the rotary knob, and then pressing ENTER.

CAUTION

The EPROMs are static sensitive devices that are susceptible to damage by routine handling. Be sure to handle the devices as explained in paragraph 3.7.

Table 3-9. Digital Circuitry Checks

Step	Item/Component	Required Condition	Remarks
1	U12, U13, U17, U30, U31 and U33	Pass RAM, EPROM, DPRAM and NVRAM tests on power up.	Display will lock if failure occurs.
2	U28, pin 18	TTL level pulse every 1msec	I/O controller VIA display clock
3	U28, pin 6 (PA4), pin 7 (PA5), pin 8 (PA6), pin 9 (PA7)	Switch data (+5V or 0V)	Data input to VIA when button pressed
4	U28, pin 11 (PB1), pin 12 (PB2)	Rotary knob data (+5V or 0V)	Data input VIA when rotary knob turned.
5	U28, pin 19	Variable pulse train (0V to +5V)	Data output to display.
6	U25, pins 34 and 35	2MHz TTL	Bus clock
7	U25, pin 37	+5V, $\pm 5\%$	Reset line (goes low momentarily on power up)
8	U27, pin 9	+5V signal pulsed 0V to +5V every 1msec	INT line
9	U27, pin 19	+5V (Logic "1")	RESET line
10	U27, pin 18	2MHz squarewave (0V to +5V)	Clock
11	U27, pin 28	Goes true (+0V) when command is sent	ATN line
12	U27, pin 24 (NDAC), 25 (NRFD), 26 (DAV), and data lines	See Figure 3-7 for required conditions	Handshake sequence
13	U14, pin 19	Variable pulse train (0V to +5V)	S/M controller VIA data to optos.
14	U14, pins 2-9 (PA0-PA7)	Variable pulse train (0V to +5V)	Data to VIA from A/D
15	U15, pins 34 and 35	2MHz TTL	Clock
16	U15, pin 37	+5V, $\pm 5\%$	Reset line (goes low momentarily on power up)

Table 3-10. Display Circuitry Checks

Step	Item/Component	Required Condition	Remarks
1	P24, pin 15 and 16	+5V, $\pm 5\%$	+5V supply
2	U5, U6, U9 and U10; OUT1 thru OUT8	Variable pulses	Segment drivers
3	U4, pins 4-7, 14-17 U7, pins 4-7, 14-17 U8, pins 4 and 5	Variable pulses	Digit drivers
4	P24, pin 10	Depress any switch located in first column of switch array on schematic (236-116).	Pulse present when button pressed
5	P24, pin 9	Depress any switch located in second column.	Pulse present when button pressed
6	P24, pin 8	Depress any switch located in third column.	Pulse present when button pressed.
7	P24, pin 7	Depress any switch located in fourth column	Pulse present when button pressed.

SECTION 4

Principles of Operation

4.1 INTRODUCTION

This section contains a general functional description of the Model 236/237. Detailed schematics and component location drawings are located at the end of this manual.

A simplified block diagram of the Model 236/237 is shown in Figure 4-1. The instrument may be divided into two sections; analog and digital circuitry. The analog and digital sections are electrically isolated from each other by the use of opto-isolators for control and communications. Separate power supplies for the analog and digital sections ensure proper isolation.

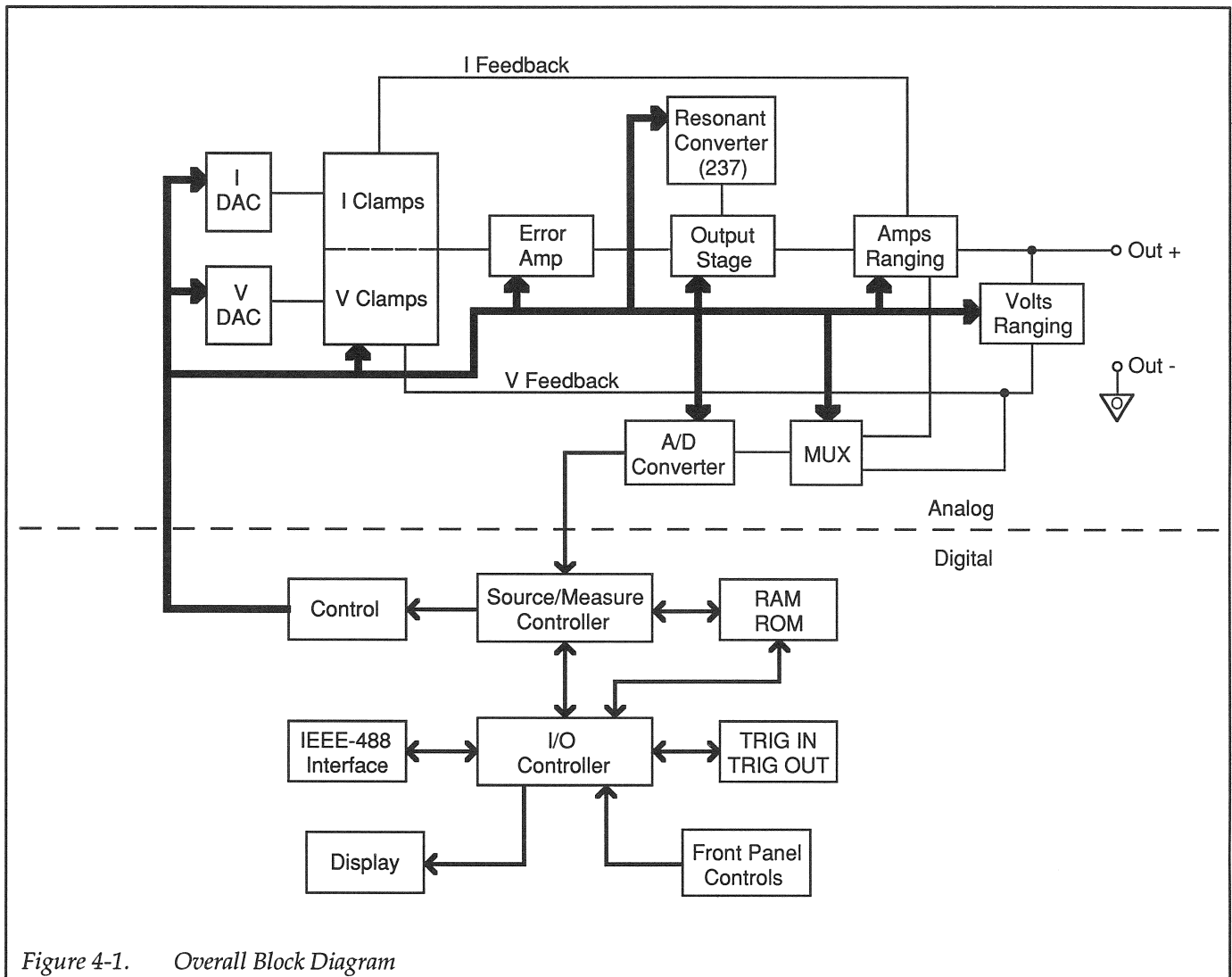

Figure 4-1. Overall Block Diagram

4.2 ANALOG CIRCUITRY

The heart of the source is an error amplifier that along with its complex scheme of feedback elements is configured as a bootstrap amplifier. Input stimulus for the amplifier is provided by two user-programmed digital-to-analog converters (DACs). The controlling function (current or voltage) and selected polarity of the source turns on one of four precision clamps allowing an input signal to be applied to the error amplifier. The output voltage from the DAC and the feedback configuration applies a voltage to the input of the error amplifier that will effect a constant level of current or voltage at the output.

Measurement is accomplished by routing properly conditioned feedback levels for voltage and current through a multiplexer to the analog-to-digital (A/D) converter.

Before proceeding to the details of circuit operation, it may be helpful to clarify what is meant by “controlling function”. If the instrument is programmed to source a specific current and it does indeed source that current, then it is considered to be current controlled. That is, current is the controlling function. If for some reason the instrument goes into compliance, the programmed current will not be sourced. Instead, the instrument sources a constant voltage (compliance voltage). Thus, voltage becomes the controlling function. Conversely, when programmed to source voltage, voltage is the controlling function unless the instrument goes into current compliance. In compliance, current becomes the controlling function.

4.2.1 V/I Control and Readback

A simplified schematic diagram of the V/I control and V/I readback circuitry is shown in Figure 4-2. The detailed schematic showing all circuit components is located on page 2 of drawing number 236-126.

Programming current and voltage sets the output voltage of the two digital-to-analog (DAC) circuits. Programming current controls the output of the I DAC (U23 and U22), and programming voltage controls the output of the V DAC (U25 and U24). Programming current or voltage for zero output will result with a 0V output from the respective DAC. Programming for a full scale output will result with a -10V output from the respective DAC.

The output voltage from the I DAC is applied to current clamps through resistor networks. Op amp U13 and diode CR11 form the negative current clamp (-I CLAMP). The output from the I DAC is inverted by the x1 amplifier U50. Op amp U17 and diode CR10 form the positive current clamp (+I CLAMP).

The output from the V DAC is inverted by the x1 amplifier U12 (x0.1 for the 1.1V range) and similarly applied to current clamps through resistor networks. Op amp U15A and diode CR12 form the positive voltage clamp (+V CLAMP). The inverted output of U12 is again inverted by U19. Op amp U15B and diode CR9 form the negative voltage clamp (-V CLAMP).

During operation, only one of the four precision clamps will be on at one time to control the error amplifier (U14). The controlling function and the programmed polarity (+ or -) will determine which clamp is on. The following example will explain how this occurs.

Example 1: This example is divided into two parts. Part 1 will explain circuit operation with the instrument sourcing a constant current. Part 2 will explain what happens when the source goes into voltage compliance.

Part 1: Assume that the instrument is sourcing +5mA with a 27V compliance to a 4kΩ load. Under these conditions the instrument is not in compliance ($5\text{mA} \times 4\text{k}\Omega = 20\text{V}$). Thus, current is the controlling function.

The I DAC outputs -5V. Thus, negative voltage appears at the non-inverting (+) input of U13 and positive voltage appears at the non-inverting (+) input of U17. The V DAC outputs approximately -3V. Positive voltage appears at the non-inverting (+) input of U15A and negative voltage appears at the non-inverting (+) input of U15B.

Since the instrument is programmed for a positive output, the ±10V REF will apply a positive voltage to the common side of the clamps. This positive voltage will reverse-bias diodes CR11 and CR9B and prevent the -I CLAMP and -V CLAMP from turning on.

With the front end of the bootstrap amplifier set up as described, -5V will be fed back (via I FEEDBACK) to U17 and U13. The non-inverting (+) input of U17 will go to 0V ($-5\text{V} + 5\text{V} = 0\text{V}$) forward-biasing CR10. As a result, the +I CLAMP turns on.

The voltage drop across the load is $20V$ ($5mA \times 4k\Omega = 20V$). This voltage is scaled down to $2V$ and inverted. This $-2V$ is fed back (via V FEEDBACK) to U15A and U15B. The non-inverting (+) input of U15B will go positive keeping CR12 reverse-biased. As a result, the +V CLAMP remains off.

Current from $\pm 10V$ REF will flow into the +I CLAMP, which is turned on (remember, the other clamps are off). As a result, the feedback configuration and the I DAC output will apply a voltage to the error amplifier (U14) that will effect a constant $+5mA$ output current.

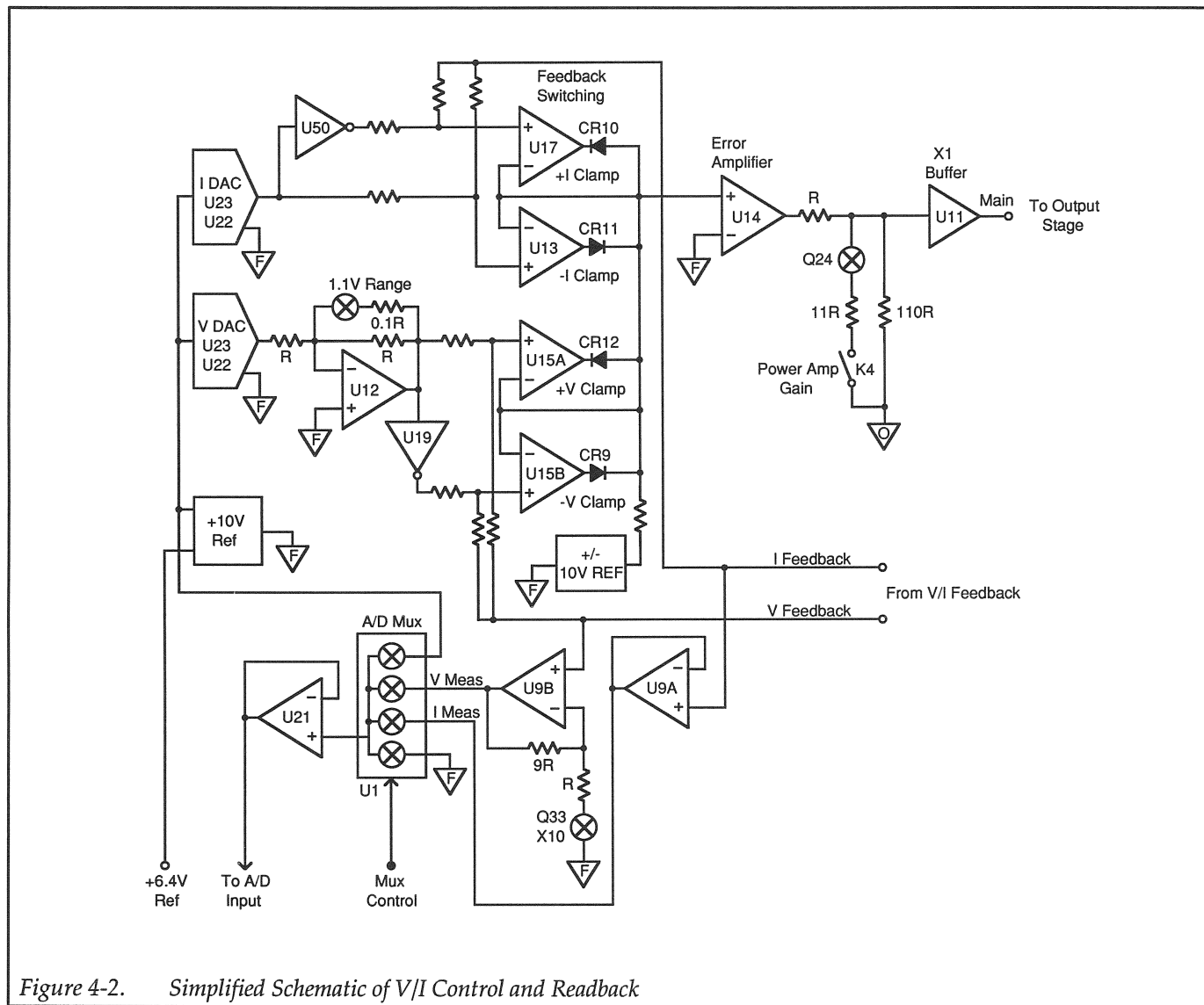

Figure 4-2. Simplified Schematic of V/I Control and Readback

Part 2: Assume the instrument is still programmed to source +5mA with a compliance of 27V. However, for one reason or another, the load resistance changes to 6k Ω . This load change causes the source to go into compliance making voltage the controlling function.

With the 4k Ω load, the +I CLAMP is on making current the controlling function (as explained in the Part 1). When the load resistance is increased to 6k Ω , the voltage drop across the load would be 30V (5mA \times 6k Ω = 30V). However, voltage is limited at 27V and the source goes into compliance.

In voltage compliance, the 27V is scaled down to 3V and inverted. This -3V is fed back (via V FEEDBACK) to U15A. The non-inverting (+) input of U15A will go to 0V (-3V + 3V = 0V) forward-biasing CR12. As a result, the +V CLAMP will turn on.

Current from \pm 10V REF starts flowing into the +V CLAMP. With less current flowing into the +I CLAMP, the voltage at the input of U14 decreases causing the output current of the source to decrease. The resultant feedback voltage to U17 will cause its (+) input to increase above 0V causing CR10 to become reversed-biased. As a result, the +I CLAMP will turn off.

With the +V CLAMP on, the instrument is voltage controlled. The output from the V DAC and the feedback configuration will apply a voltage to the error amplifier (U14) that will effect a constant output voltage of +27V.

Bootstrap amplifier gain is controlled at the output of the error amplifier (U14) by the FET switch Q24 and relay K4. On the 110V and 1100V ranges, the switches are open and x110 gain is provided. On the lower voltage ranges the switches are closed providing x11 gain. Device U11 is a x1 buffer between the V/I control circuit and the output module.

Measurement is accomplished by routing properly conditioned voltage feedback levels (I FEEDBACK and V FEEDBACK) through a multiplexer to the analog-to-digital (A/D) converter. Op amp U9A is configured as a unity gain amplifier to function as buffer for I FEEDBACK. Op amp U9B is configured as a non-inverting amplifier for V FEEDBACK. On the 1.1V range, the FET switch Q33 is closed providing x10 gain. On the higher voltage ranges, the FET switch is open configuring U9B

as a unity gain amplifier. The four signals (+10V reference, V Measure, I Measure and floating common) are multiplexed (U1) and routed to the A/D converter via buffer U21.

4.2.2 Output Stage

The output stage of the bootstrap amplifier basically consists of a class AB circuit whose bias is controlled by the output of the error amplifier.

Model 236

The simplified schematic diagram of the output stage for the Model 236 is shown in Figure 4-3. The detailed schematic of the output stage is found on drawings 236-166 and 236-126 (page 2).

At the heart of the output stage are power transistors Q21 and Q19. The collector of Q21 is effectively connected to the +150V, 120mA power supply, while the collector of Q19 is effectively connected to the -150V, 120mA power supply.

When programmed for a zero output, both Q21 and Q19 are zero-biased (off). The \pm 150V supplies are dropped across the high impedance of these two transistors. As a result, zero voltage is present at the output (floating common to output common). When the source is programmed for a positive output, Q21 becomes forward-biased (on). The voltage drop across Q21 becomes less than +150V. As a result, the voltage present at the output is the difference between the supply voltage (+150V) and the voltage drop across Q21. For a positive output, Q19 is reverse-biased (off) keeping the negative supply isolated from the output.

Circuitry for a negative output functions in a similar manner. When the source is programmed for a negative output, Q19 becomes forward-biased, resulting with a negative voltage present on the output. Transistor Q21 is reverse-biased isolating the output from the positive supply.

Bias for the two power transistors are provided by the \pm 30V supplies and two 15V zener diodes (VR10 and VR9). This bias circuit is referenced to floating common in order to maintain the bases of the transistors at a voltage that is higher than the output so that they can be forward-biased. Bias control is performed by the output of

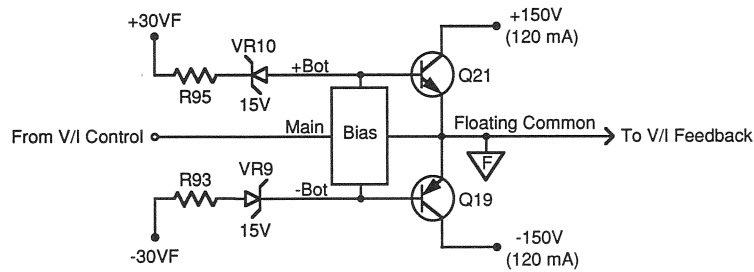

Figure 4-3. Model 236 Output Stage (Simplified Schematic Diagram)

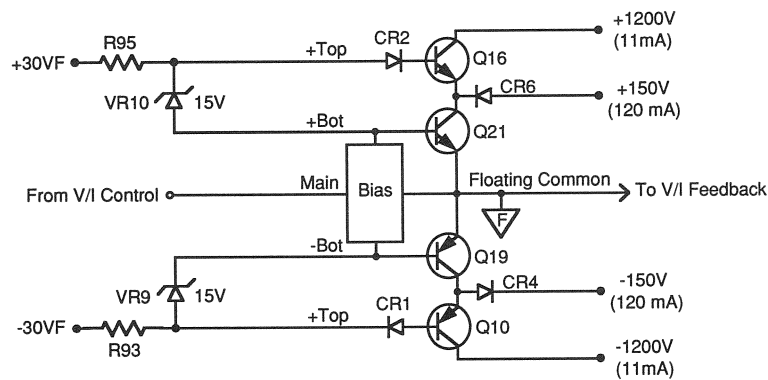

Figure 4-4. Model 237 Output Stage (Simplified Schematic Diagram)

the error amplifier (MAIN drive). The polarity and magnitude of MAIN determines which transistor is forward-biased and the amount of bias current that in turn determines the magnitude of the output voltage. For example, as a positive MAIN becomes more positive, more bias current is delivered to the base of Q21 resulting in a higher output voltage.

Model 237

The simplified schematic diagram for the output stage for the Model 237 is shown in Figure 4-4. The detailed schematic of the output stage is found on drawings 237-166 and 236-126 (page 2).

For low voltage, the output stage for the Model 237 functions the same as the one for the Model 236 (see explana-

tion for Model 236 output stage). However, additional circuitry is used to switch over to the 1200V supplies needed for programmed source voltages exceeding 150V. The $\pm 1200\text{V}$ supplies for the Model 237 are derived from a resonant converter circuit (see paragraph 4.2.4).

For voltage outputs of $\leq 150\text{V}$, Q21 and diode CR6 is forward biased providing source output from the low voltage (+150V), high current (120mA) supply. Transistor Q16 is reverse-biased (off) and therefore disconnects the 1200V supply from the output. As the voltage output approaches 150V, CR2 conducts via the 15V zener (VR10) and Q16 turns on. At 150V, Q21 is effectively saturated. As the output voltage exceeds 150V, CR6 becomes reverse-biased and turns off disconnecting the 150V supply from the output. For $>150\text{V}$, only the high voltage (1200V), low current (11mA) supply is connected to the output. Power supply switching occurs in a similar manner for negative output voltage.

4.2.3 V/I Feedback

A simplified schematic diagram of the V/I feedback circuitry is shown in Figure 4-5. The detailed schematic of this circuitry is provided by page 3 of drawing 236-126.

Amps Ranging — Current range selection is accomplished by activating the appropriate range FET and/or relay. The nominal range resistances are shown in the illustration (Figure 4-5). The FET labeled QAB for the 100mA range is actually a composite P and N-channel FET. A more detailed look at the 100mA range is shown in Figure 4-6. In reality, QA is comprised of P-channel FETs Q8 and Q9, and QB is comprised of N-channel FETs Q6, Q7, Q37 and Q38.

Without special circuitry, current measurement range changes may cause voltage spikes to occur at the output. Voltage spikes are caused by contact bounce of the selected range relay. These spikes occur too fast for the bootstrap amplifier to react to the change in feedback

voltage. As a result, the system cannot adjust itself accordingly to maintain a steady voltage output.

The Model 236/237 resolves this problem by using circuitry that, in effect, shunts the current ranges with a 100Ω resistor whose voltage drop ramps in a linear fashion towards 0V. This slow rate of voltage change allows the system to adjust itself keeping the output voltage constant (spike free). The circuitry that accomplishes this consists of FETs QA and QB, and the ±15V-to-0V ramps that control them.

The following sequence takes place when a current measurement range change occurs:

1. Relay K8 closes.
2. The appropriate ramp is activated (RANGE 2 RAMP for + polarity, or RANGE 1 RAMP for - polarity). The ramp on the gate of the appropriate FET results with a corresponding voltage ramp across the 100Ω resistor.
3. The other ramp is activated. Turning on the second FET increases the current carrying capability of the circuit. With both FETs fully on, the current ranges are shunted by the 100Ω resistor.
4. The new range relay and/or FET is activated.

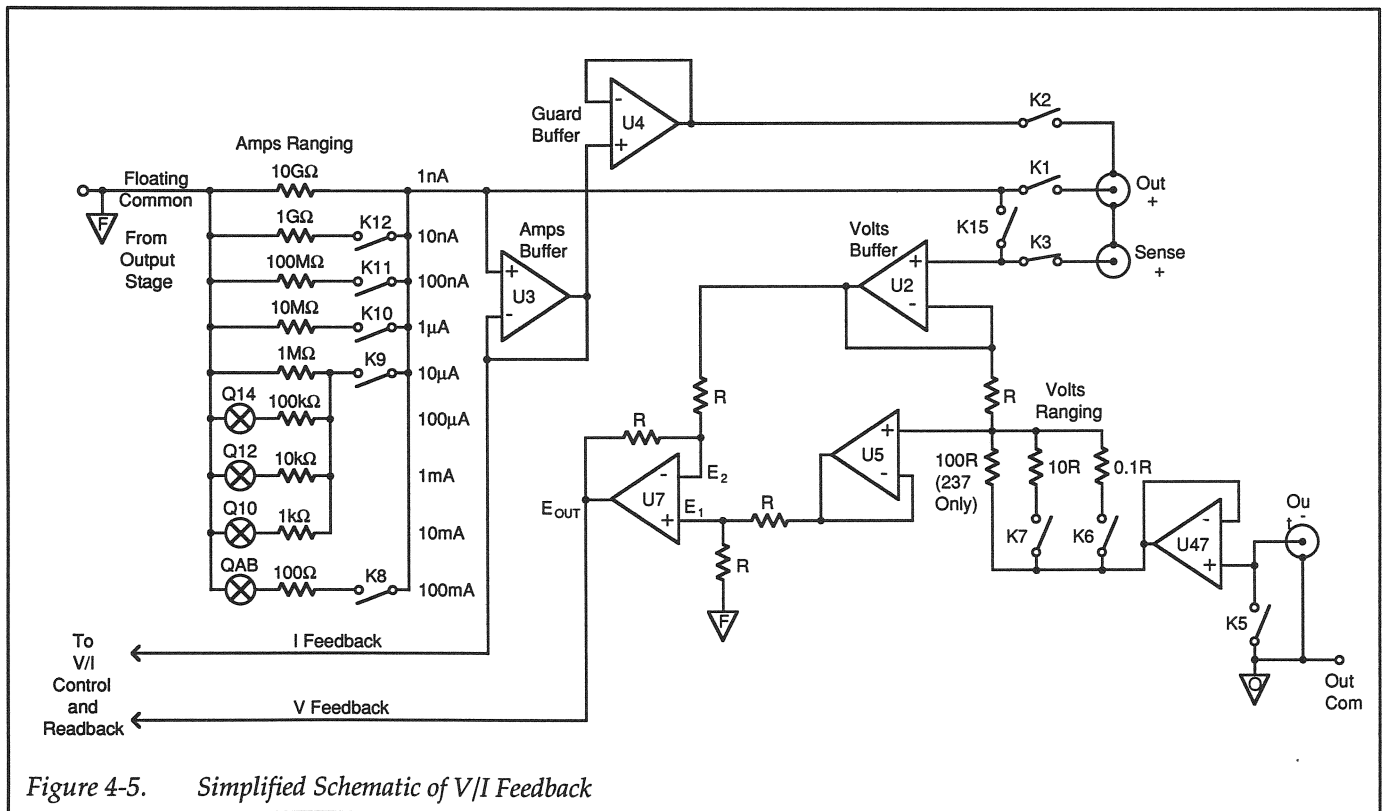

Figure 4-5. Simplified Schematic of V/I Feedback

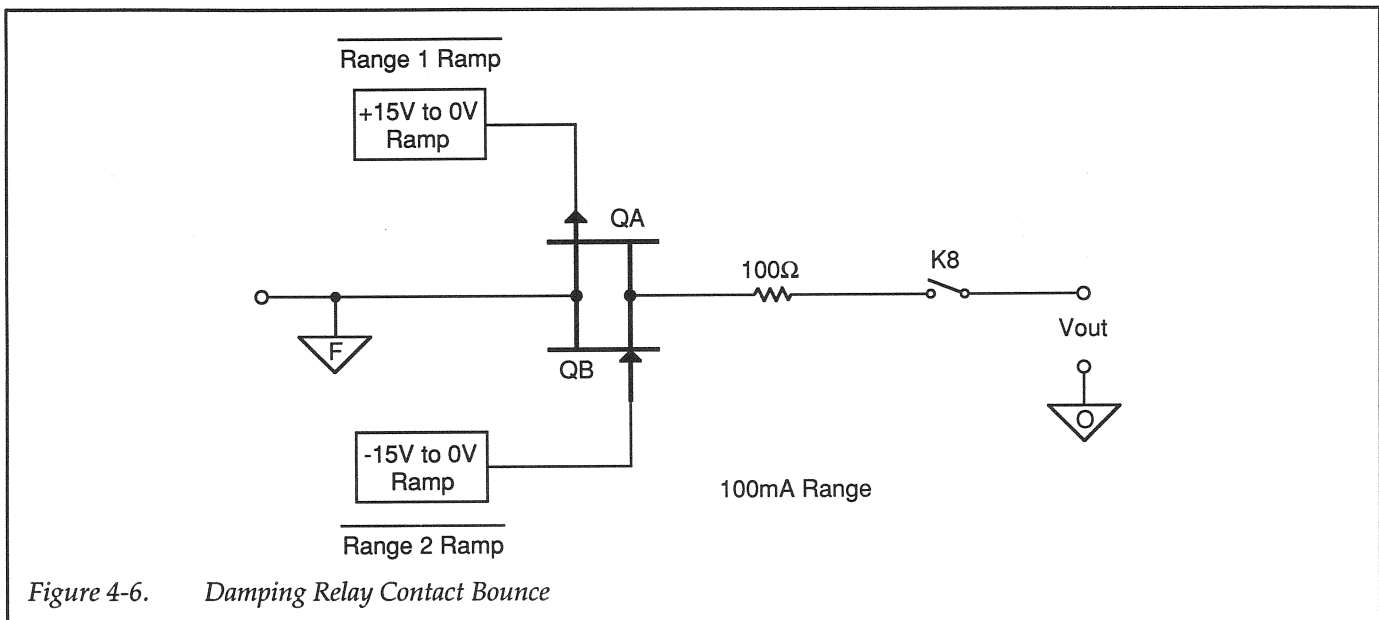

Figure 4-6. Damping Relay Contact Bounce

Note: If the 100mA range is the new range, it is already selected. The range change sequence stops at this point. If a different range is selected, continue on to the next steps.

5. The two voltage ramps are disabled in reverse order.
6. Relay K8 opens completing the range change.

When the 100mA source range is selected, K8 closes and both ramps are activated to turn on both FETs. As long as the 100mA range is selected, 0V is maintained at the gates of the FETs to keep them on.

Op amp U3 is a unity gain amplifier that serves as a buffer between the output and I FEEDBACK. I FEEDBACK is fed back to V/I Control and Readback where it completes the feedback loop and is also routed to the A/D converter for measurement.

Guard — The x1 output of U3 is also routed to another x1 buffer amplifier (U4) whose output is used as the driven guard for the instrument. Buffer U4 isolates the driven guard from I FEEDBACK.

Volts Ranging and Sensing — The voltage range resistors are part of a voltage divider network. In general, OUT + is applied to the top of divider. The output of the divider is then routed to a differential amplifier. The other input to the differential amplifier is effectively OUT

+. The output of the x1 differential output is then fed back to the V/I Control and Readback circuitry.

Op amp U2 is configured as a unity gain amplifier that serves as a buffer between the output and volts ranging circuitry. In local sense (K15 closed, K3 open), the output is accessed internally. In remote sense (K15 open, K3 closed), the output is accessed at the load. The x1 output of U2 is applied to the – input of the differential amplifier (U7).

The output of U2 is also applied to the top of the voltage divider for volts ranging. The bottom of the voltage divider network is connected to output common (OUT –) via op amp U47 which is configured as a x1 buffer. In local sense (K5 closed), OUT – is accessed internally. In remote sense (K5 open), OUT – is accessed at the load.

Volts range relays K6 and K7 determine the resistance of the bottom leg of the voltage divider. Table 4-1 identifies the relays for each voltage range. The output of the voltage divider is routed to the + input of the differential amplifier (U7) via op amp U5 which serves as a x1 buffer.

Op amp U7 is configured as a x1 differential amplifier. The output voltage (V_{out}) of this amplifier will be the algebraic difference of its two inputs ($E_1 - E_2 = V_{out}$). V_{out} (V FEEDBACK) is routed back as a bootstrap amplifier feedback loop and also to the A/D multiplexer for measurement.

Table 4-1. Volts Range Relays

236/237 Range	Relays Energized
1.1V	K6, K7
11V	K6, K7
110V	K7
1100V	None

4.2.4 Resonant Converter (Model 237)

The $\pm 1200V$ supplies required for the Model 237 are provided by the resonant converter. A simplified schematic diagram of the resonant converter is shown in Figure 4-7. The detailed schematic is found on drawing 237-176.

The $\pm 1200V$ switching supply is basically a low noise, low EMI/RFI dc-to-dc converter. This high voltage supply is derived from the +50V power supply.

In general, an LC resonant circuit is used to produce a current that resembles a sinusoidal ac waveform. As a result, an alternating voltage waveform is applied to a step-up transformer. The output voltage of the transformer is then fed to an eight stage voltage multiplier where voltage is increased to $\pm 1200V$.

The resonant tank circuit (L_R , T2 and C_R) is controlled by the voltage controlled oscillator (VCO), and switching FETs Q1 and Q2. The VCO generates pulse pairs to drive Q2 and Q1. During each pulse pair, the two FETs are alternately driven on and off.

During each pulse pair, FET switch Q2 turns on and a current that resembles the positive portion of an ac sinusoidal waveform is generated in the tank circuit. FET Q2 turns off and, after a short period of time, FET Q1 turns on. Current flows through the tank circuit in the opposite direction producing the negative portion of the ac waveform. As a result, an alternating voltage waveform is applied to the primary of transformer T2. The speed of the oscillator (VCO) varies. Its frequency increases (up to 50kHz) as the load requires more current.

For simplicity, only two stages of the voltage multiplier are shown in Figure 4-7. As shown the, circuit on the secondary of T2 is configured as a voltage doubler for +V

and -V outputs. When voltage on the secondary of T2 is negative, current will flow through diode CR19 and charge capacitor C28. For example, with the secondary of T2 at -245V, C28 will charge to +245V. When the voltage on T2 reverses direction to +245V, the result is two voltage sources (T2 and C28) in series. The voltage at +V is +490V (VT2 + VC28). The circuit for -V output operates in a similar manner. That is, C27 is charged to -245V and when T2 reverses direction to -245V, -490V is present at -V.

In actual circuit implementation, six more stages are used; three for positive voltage and three for negative voltage. For the positive output, capacitors C28, C32, C36 and C40 are all charged by T2 resulting with a +1200V output. On the negative side, capacitors C27, C31, C35 and C39 are charged by T2 resulting with a -1200V output.

4.3 A/D CONVERTER

The Source Measure Unit uses a constant frequency, variable pulse width, analog-to-digital converter. The schematic diagram for the A/D converter is located on page 3 of drawing 236-106.

Reading conversions start with a charge balance phase and end with a single slope phase, thus producing two sets of counts from U47 back to the pre-scale counter (U21) and VIA of the source/measure controller.

The A/D input is applied to current offset resistors R63 and R64. The input current is applied to the gate of Q4 via FET switch Q2 converting the bipolar $\pm 10V$ input to a unipolar current. Operational amplifier U50 and Q4 form an integrator with capacitor C63. This integrator ramps in a positive direction (since the current is negatively offset) until it reaches a threshold, or until a timebase interval occurs and switches on a balance current. This continues for a length of time that is determined by the value in register U44 which is programmed by the source/measure controller.

Device U45 is an 8 bit magnitude comparator which continuously compares the set value to the count value in counter U46. When these two numbers match, the output on pin 19 of U45 stops the A/D converter, thus signaling the end of the charge-balance phase. After determining that the charge balance has stopped (by monitoring counts or timing out), the software sets the final-slope balance line high. This clears U46 making it ready for a

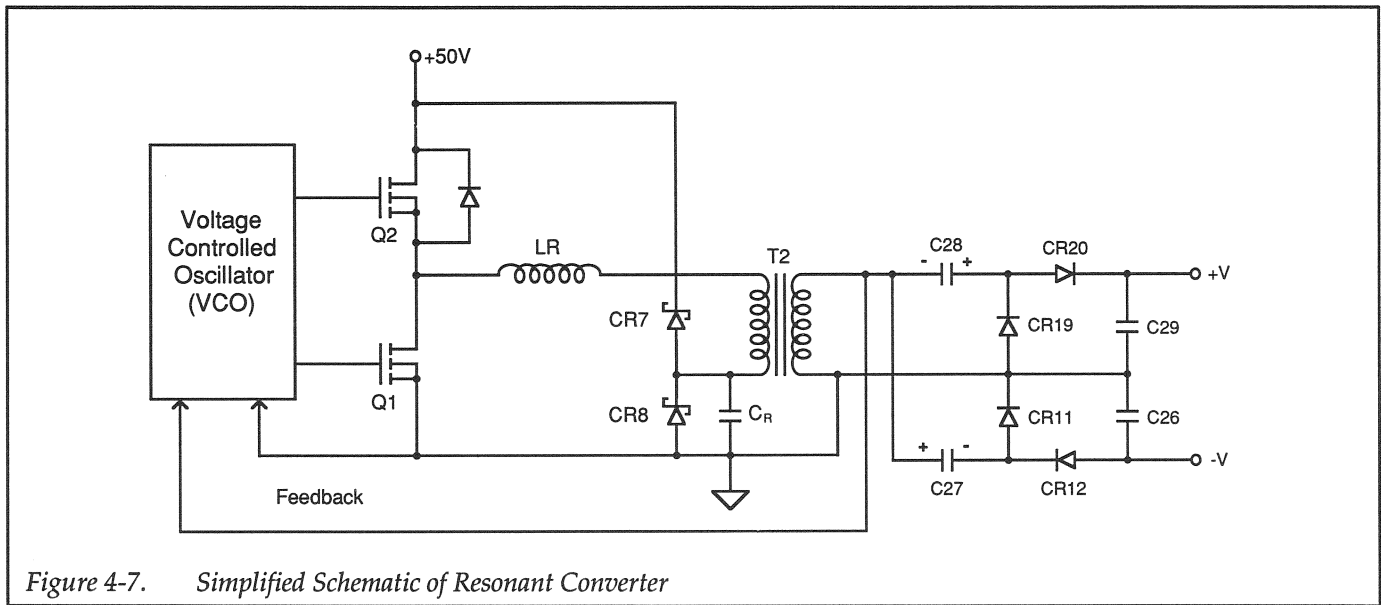

Figure 4-7. Simplified Schematic of Resonant Converter

new charge-balance phase, and starts the final-slope phase of the A/D converter.

The final-slope phase essentially removes all charge remaining on the integrator by ramping the output of U50 to 0V. Counts are accumulated during the final-slope and used for calculation of the effective input signal. The A/D converter is run through a number of phases that are used to null any error signals present in the A/D or analog front end.

The time base for the A/D converter is provided by an oscillator that consists of inverter U57 and crystal Y2. The 7.68MHz time base, which is a multiple of 60Hz, is divided by counters U41 and U40 to provide system timing functions for charge balance control. The 7.68MHz is fed directly to NOR gate U47 where it is gated on and off by the rest of the A/D function. The A/D power supply reference voltages, -10V, and +5V are derived from operational amplifier U56 and associated circuitry. These are reference voltages used in generating currents and thresholds for the A/D converter.

4.4 DIGITAL CIRCUITRY

The schematic diagrams for the digital circuitry are located in last section of this manual, drawing number 236-106.

The Source Measure Unit is controlled by two 6809 8-bit 2MHz N-MOS microprocessors. These two microprocessors coordinate all instrument functions. These include running the display and keyboard, servicing the IEEE-488 interface, and control of all analog functions.

4.4.1 I/O Controller

The schematic diagram for the I/O controller is provided on page 1 of drawing 236-106.

The I/O controller controls the display and front panel controls, the IEEE-488 interface, test fixture lid closure detection, and TRIGGER IN and TRIGGER OUT. It also maintains calibration constants, and contains the major portion of the operating system for the instrument.

At the heart of the I/O controller system is an 8-bit 68B09 microprocessor running at 2MHz. The system master oscillator Y1 is an 8MHz canned crystal oscillator. I/O controller peripherals include a 64K X 8 ROM (U31) which contains the program memory, a 32K X 8 static CMOS RAM (U30) which is battery backed up via U29 and the battery (BT1). Calibration constants are stored in non-volatile memory (U33; E²ROM). A versatile interface adapter (U28) provides peripheral interface to the 6809 microprocessor. It is primarily used to interface with the display and keyboard. It is also used to interface TRIGGER OUT and TRIGGER IN, as well as monitor the test fixture lid detect interface. A 9914 IEEE-488 standard interface (U27) is combined with two transceivers (U34 and

U35) to provide the interface function. All of these peripheral chips are interfaced to the 6809 via a programmable logic device (U26; PAL 16L8).

A NOR gate package (U32) is used to provide protection for calibration constants stored in non-volatile memory (U33) during power-up and power-down.

A power-up reset control circuit (U36) guarantees a delayed reset after power-up and a prompt reset on power-down by sensing power supply threshold.

4.4.2 Source/Measure Controller

The schematic diagram for the source/measure controller is provided on page 2 of drawing 236-106.

This controller system also uses a 68B09 microprocessor (U15). As with the I/O controller (see previous paragraph), it derives its 2MHz operating frequency from the 8MHz crystal (Y1). The peripherals for this 6809 include 32K of ROM (U17), 32K of static RAM (U13), and a versatile interface adapter (U14) which provides interface to the analog circuitry as well as a few other miscellaneous functions.

Devices U18, U19 and U58 are binary counters that form the core of a software watch-dog timer. This timer monitors software execution of both CPUs via lines that are regularly toggled. If any line fails to toggle within approximately 4msec the entire system will be reset.

As with the I/O controller, all the peripheral chips of the source/measure controller are decoded and controlled by a programmable logic device (U16; PAL 16L8). A/D control as well as A/D counts accumulation are performed by the VIA (U14) with a prescale counter (U21). Inverters (U23) provide a software selectable enable for the high voltage converter in the Model 237 only.

4.4.3 Communications

The schematic diagram for the communications circuitry is located on page 4 of drawing 236-106.

Communications are provided by opto-couplers that serve as an interface between the source/measure con-

troller and the analog circuitry. This particular circuit is fairly unique in that control signals are sent through two optos that are driven 180° out of phase with one another to provide immunity from false glitching.

The outputs of the complimentary opto-couplers are decoded by programmable logic device U1 (PAL 20L10). From U1, the signals are sent to various places on the analog board by decoder U39 which determines one of four clock paths as set by the bank select signals 0 and 1 which are also derived from U1. This circuit topology provides for a very reliable communications scheme such that the analog circuitry can never receive false data.

Opto-couplers AT1, AT2, AT3, AT7 and AT8 are all involved in the transmission of clock, data, strobe, and the two bank select signals from the VIA of the source/measure controller to the analog board. Opto-coupler AT4 is the high voltage enable coupler which enables the high voltage resonant converter in the Model 237. Opto-coupler AT5 returns a CV/CC constant voltage or constant current level signal to the source/measure controller so that the present state of the analog output can be determined. The A/D converter counts are returned to the microprocessor of the source/measure controller by AT6 which is a high speed opto-coupler.

4.4.4 Display Circuitry

The schematic diagram for the display circuit is provided on drawing 236-116.

The display, which is controlled by the I/O controller, is basically an 18-digit alpha-numeric LED display. It consists of nine two-digit display elements (DS1 through DS9). Each of these display elements are multiplexed in a matrix fashion. Each display digit has its common cathode connected to sink drivers (U4, U7 and U8). These sink drivers are switched on in a rotating fashion.

The display is divided into two banks of ten columns such that the DS1 left digit and DS6 left digit are on simultaneously, as can be evidence by the common connections of the inputs of U4 pin 3 and U7 pin 8. This allows the display to be refreshed faster, thus eliminating flicker associated with line frequency beating with lighting and such. The front panel indicator LEDs (DS10 through DS29) are driven in a similar manner by sink drivers of U8. The anodes of the two separate banks of display elements are driven by source drivers U5 and U6 (left bank), and U9 and U10 (right bank). These are serial input, par-

allel output combination shift register/drivers. They interface directly to the I/O controller VIA clock data interface. A strobe is provided by software to load the outputs of the drivers with data. The displays are indexed at a 100Hz (1ms) rate.

Circuit components U1 and U2 provide a timer function that allow the selection of either a bright or dim digit and is used for flashing cursor digits. A counter (U2) times out after 256 μ sec and bit 16 of the two serial bank source drivers is fed back into U1 pin 12 and U1 pin 6. Depending on the states of these bits, the LEDs will be on for the entire 1msec duration or 1/4 (256 μ sec) duration. The column drivers are selected by a one-of-ten decoder (U3) which is directly driven from the VIA of the I/O controller. These columns, as they are selected, also select columns in the front panel key switch matrix through diodes CR1 through CR10. The column driven low, and the four lines fed back to the VIA of the I/O controller identify which key is pressed.

4.5 POWER SUPPLY

The schematic diagram for the power supply is located on page 4 of drawing 236-106.

The power supply consists of an off line transformer (T1) which has selectable 115/230V operation. It is essentially two 115 volts primaries either in series or parallel. In parallel with one of the primary windings is the cooling fan allowing it to always operate on 115V. The line select switch (S2) allows user selectable line voltages. Switch S1 is the main power switch, F1 is the system fuse, and J2 is a rear panel mounted line filter connector. The secondary of the transformer provides all of the power supply voltages.

The digital power supply (gray transformer secondaries on schematic) is capable of delivering +5V at 1.2A to power all digital and front panel circuit components. Full

wave rectification is provided by the bridge rectifier CR1. Capacitors C106 and C107 provide spike suppression, while C4 provides filtering. Voltage regulation is provided by VR1 with capacitor C24 on its output for stability.

The ± 15 V and ± 30 V analog supplies are derived from the orange colored secondaries. The ± 15 V power supply consists of a bridge rectifier CR4, filter capacitors C53 and C55, ± 15 V regulators VR3 and VR4, and stability capacitors C91 and C92. A voltage doubler circuit consisting of diodes CR2, CR3, CR6 and CR7, and storage capacitors C52, C54, C56 and C57 combine with adjustable regulators VR5 and VR6, and resistors R6, R7, R8 and R9 to provide the ± 30 V outputs.

The +5V analog supply (brown secondaries) consists of the bridge rectifier CR5, filter capacitor C7, regulator VR2, and output capacitors C93 and C15. This power supply provides +5V for analog functions.

The ± 150 V supply (yellow secondaries) is provided for the bootstrap amplifier. A bridge rectifier is configured from four diodes; CR8, CR9, CR10 and CR11. These diodes rectify and use capacitors C58 and C59 as storage elements. A ± 15 V analog supply is derived from a shunt regulator circuit consisting of resistors R73 and R74, and regulators VR7 and VR8 in parallel with capacitors C95 and C96.

The +50V supply (blue secondaries) is used to drive the high voltage converter of the Model 236. The Model 237 uses this 50V supply to derive the ± 1200 V output. Bridge rectifier CR12 and CR27 provide full wave rectification, while C110 and R80 suppress diode spikes. Thyristor Q7, zener diode VR9, and resistor R90 provide an SRC clamping circuit such to guarantee that fuse F1 will clear when the instrument is set for 115V operation while connected to the 230V line. Minimal load is guaranteed by resistor R69 and filter function is provide by capacitor C10.

SECTION 5

Replaceable Parts

5.1 INTRODUCTION

This section contains replacement parts information, component location drawings and schematic diagrams for the Models 236 and 237.

5.2 PARTS LISTS

Parts are listed alphanumerically in order of their circuit designations. The first parts list contains information for the display board of both the Models 236 and 237. The next parts list contains information for the digital board of both the Models 236 and 237. The next parts list contains information for the analog board of both the Models 236 and 237. The next two parts lists contain information for the output modules of the Models 236 and 237 respectively. The next parts list contains information for the resonant converter of the Model 237. The last parts list contains information on miscellaneous parts that do not pertain to any of the pc boards.

5.3 ORDERING INFORMATION

To place an order, or to obtain information concerning replacement parts, contact your Keithley representative or

the factory. See inside front cover for addresses. When ordering, include the following information:

1. Instrument Model Number
2. Instrument Serial Number
3. Parts Description
4. Circuit Designation (if applicable)
5. Keithley Part Number

If an additional service manual is required, order part number 236-902-00. The manual package will contain the service manual and any applicable addenda.

5.4 FACTORY SERVICE

If the instrument is to be returned to the factory for service, please complete the service form which follows this section and return it with the instrument.

5.5 SCHEMATIC DIAGRAMS AND COMPONENT LOCATION DRAWINGS

Schematic diagrams and component location drawings follow the appropriate replaceable parts list for that particular board.

MODEL 236/237 DISPLAY BOARD, PARTS LIST

CIRCUIT DESIG.	DESCRIPTION	KEITHLEY PART NO.
C1..C4 C5	CAP,.01uF,20%,50V,CERAMIC CAP,10uF,-20+100%,25V,ALUM ELEC	C-365-.01 C-314-10
CR1..CR10	DIODE,SILICON,IN4148 (DO-35)	RF-28
DS10..DS28 DS1..DS9 DS29	PILOT LIGHT,RED,LED DISPLAY,DIGITAL (DOUBLE DIGIT) RECTANGULAR LIGHT SOURCE FOR DS10..DS28 MOUNTING KIT	PL-71 DD-39 PL-81 MK-22-1
P24	CABLE ASSEMBLY, 20 CONDUCTOR	CA-27-9
R1..R23,R25,R27, R24,R26 R28,R32 R29..R31,R33,R34	RES,82,5%,1/4W,COMPOSITION OR FILM RES,15,5%,1/4W,COMPOSITION OR FILM RES,3.3K,5%,1/4W,COMPOSITION OR FILM RES,82,5%,1/4W,COMPOSITION OR FILM	R-76-82 R-76-15 R-76-3.3K R-76-82
S1 S2..S34	DIGITAL CONTACTING ENCODER SWITCH, MOMENTARY	SW-472 SW-435
U1 U2 U3 U4,U7,U8 U5,U6,U9,U10	IC,QUAD 2 INPUT OR,74HC02 IC,12 STAGE BINARY COUNTER,74HC4040 1 OF 10 DECODER,74HC42 IC,350mA SATURATED SINK DRIVER UDN-2596A IC,8-BIT,SERIAL-INPUT,5895A-2	IC-412 IC-407 IC-583 IC-578 IC-537

MODEL 236/237 DIGITAL BOARD, PARTS LIST

CIRCUIT DESIG.	DESCRIPTION	KEITHLEY PART NO.
	A/D BOTTOM SHIELD	236-325
	A/D SHIELD	236-311
	BATTERY HOLDER	BH-34
	CONN, MALE 5 PIN	CS-288-5
	CONN, MALE 3 PIN	CS-288-3
	FUSE CARRIER	FH-25
	FUSE HOLDER	FH-21
	PUSHBUTTON, TAN	31470-4
	STANDOFF, #10 CLEARANCE	ST-194-1
	STANDOFF (#4 CLEARANCE)	ST-195-1
	STANDOFF (#4-40)	ST-137-2
	CONN, MALE, 10 PIN	CS-288-10
	CONN, MALE 4 PIN	CS-288-4
	CONN, MALE, 6 PIN	CS-288-6
AT1-AT3, AT7, AT8	IC, DUAL HIGH CMR/SPEED OPTO, HCPL-2631	IC-588
AT4, AT5	IC, OPTOCOUPLER, 2601	IC-239
AT6 -AT8	IC, OPTOCOUPLER, HCPL-2400	IC-464
BT1	BATTERY, LITHIUM COIN CELL, 3V	BA-44
C1	CAP, 33pF, 10%, 1000V, CERAMIC	C-64-33P
C10	CAP, 4700uF, -20+100%, 63V, ALUM ELEC	C-402-4700
C100..C102	CAP, .01uF, 20%, 50V, CERAMIC	C-365-.01
C103, C105, C112	CAP, .1uF, 20%, 50V, CERAMIC	C-365-.1
C104	CAP, .01uF, 20%, 50V, CERAMIC	C-365-.01
C106, C107	CAP, .1uF, 20%, 50v, CERAMIC	C-237-.1
C108, C109	CAP, .02uF, 20%, 500V, CERAMIC	C-22-.02
C110, C111	CAP, .1uF, 20%, 100v, CERAMIC	C-416-.1
C113-C116	CAP, 710pF, 2%, 50V, CERAMIC	C-348-710p
C14, C18, C20..C22	CAP, .1uF, 20%, 50V, CERAMIC	C-365-.1
C15..C17, C24, C33	CAP, 10uF, -20+100%, 25V, ALUM ELEC	C-314-10
C23, C26..C28,	CAP, .01uF, 20%, 50V, CERAMIC	C-365-.01
C30..C32, C34..C38		
C4	CAP, 10,000uF, -20+30%, 25V, ALUM ELEC	C-342-10,000
C42..C47, C49..C51	CAP, .01uF, 20%, 50V, CERAMIC	C-365-.01
C52, C54	CAP, 100uF, 20%, 63V, ALUM ELEC	C-403-100
C53, C55	CAP, 1000uF, -10+100%, 35V, ELECTROLYTIC	C-309-1000
C56, C57	CAP, 100uF, -10+100%, 35V, ALUM ELEC	C-295-100
C58, C59	CAP, 560uF, 20%, 200V, ALUM ELEC	C-355-560
C60, C61, C100..	CAP, .01uF, 20%, 50V, CERAMIC	C-365-.01
C102		
C62, C65, C66, C69	CAP, .1uF, 20%, 50V, CERAMIC	C-365-.1
C63	CAP, .0047uF, 10%, 100V, POLYPROPYLENE	C-306-.0047
C64	CAP, 820pF, 10%, 1000V, CERAMIC	C-64-820P
C67	CAP, 22pF, 10%, 1000V, CERAMIC	C-64-22P
C68, C70, C72	CAP, 47pF, 10%, 1000V, CERAMIC	C-64-47P
C7	CAP, 4700uF, -20+100%, 16V, ALUMINUM	C-313-4700
C71	CAP, 22pF, 20%, 500V, CERAMIC	C-22-22P
C73, C89..C93	CAP, 1uF, 20%, 50V, CERAMIC	C-237-1
C74..C87, C98, C99	CAP, .1uF, 20%, 50V, CERAMIC	C-365-.1

C94	CAP,10uF,-20+100%,25V,ALUM ELEC	C-314-10
C95..C97	CAP,1uF,20%,50V,CERAMIC	C-237-1
CR1	DIODE,BRIDGE,PE05 (CASE KBU)	RF-48
CR12	DIODE,BRIDGE,KBU4B (CASE KBU)	RF-64
CR13..CR16,CR19	DIODE,SILICON,IN4148 (DO-35)	RF-28
CR2,CR3,CR6,CR7	DIODE,SWITCHING,IN4607 (DO-35)	RF-41
CR20,CR23...CR26		
CR27	DIODE,SILICON,IN4007 (DO-41)	RF-50
CR4,CR5	DIODE,BRIDGE,VM18	RF-52
CR8..CR11	DIODE,SILICON,IN4006 (DO-41)	RF-38
F1	(110V LINE) FUSE.1.0A,250	FU-4
J10	CONN,RIGHT ANGLE,24 PIN	CS-507
J16	MODIFIED,CONNECTOR	590-314-4
J18,J21	MODIFIED,CONNECTOR	590-314-10
J20	MODIFIED CONNECTOR	236-329
J22	CONN,MALE 3 PIN	CS-288-3
J23	MODIFIED,CONNECTOR	590-314-6
J24	CONN,DUAL 10-PIN-BERG	CS-389-8
J8	MODIFIED,CONNECTOR	590-314-3
L1	CHOKER,10uH	CH-16
P19	CABLE ASSEMBLY, 14 CONDUCTOR	CA-27-12
Q2	TRANS,N-CHANNEL FET,TN06L	TG-216
Q3	TRANS,N CHANNEL JFET,PN5434 (TO-92)	TG-174
Q4	TRANS,N CHANNEL DUAL FET,MP842 (TO-52)	TG-175
Q5	TRANS,NPN SILICON,2N3904 (TO-92)	TG-47
Q6	TRANS,N CHANNEL FET,2N4392 (TO-92)	TG-128
Q7	TRANS,THYRISTOR,MAC223A6	TG-172
R1	RES,430,5%,1/4W,COMPOSITION OR FILM	R-76-430
R15,R17,R50,R91	RES,1K,5%,1/4W,COMPOSITION OR FILM	R-76-1K
R16,R23	RES NET,3.3K,5%,.11W	TF-140
R2,R30	RES,330,5%,1/4W,COMPOSITION OR FILM	R-76-330
R20..R22,R71	RES,100,5%,1/4W,COMPOSITION OR FILM	R-76-100
R25,R72,R77	RES,3.3K,5%,1/4W,COMPOSITION OR FILM	R-76-3.3K
R28,R83,R84	RES,470,5%,1/4W,COMPOSITION OR FILM	R-76-470
R3,R4,R10,R11	RES,470,5%,1/4W,COMPOSITION OR FILM	R-76-470
R32	RES,560K,5%,1/4W,COMPOSITION OR FILM	R-76-560K
R33	RES,6.2K,5%,1/4W,COMPOSITION OR FILM	R-76-6.2K
R34	RES,2K,5%,1/4,COMPOSITION OR FILM	R-76-2K
R35,R75,R76	RES,47K,5%,1/4W,COMPOSITION OR FILM	R-76-47K
R36	RES,100,1%,1/8W,METAL FILM	R-88-100
R37	RES,4.87K,1%,1/8W,METAL FILM	R-88-4.87K
R38,R39	RES,10K,5%,1/4W,COMPOSITION OR FILM	R-76-10K
R41	RES,142.2K,.02%,1/8W,PRECISION THIN FILM	R-365-142.2K
R42	RES,100K,5%,1/4W,COMPOSITION OR FILM	R-76-100K
R43	POT,10K,10%,.5W,NON-WIREWOUND	RP-97-10K
R44,R47	RES,200,5%,1/4W,COMPOSITION OR FILM	R-76-200
R45,R48	RES,20K,1%,1/8W,METAL FILM	R-88-20K
R46	RES,32.4K,1%,1/8W,METAL FILM	R-88-32.4K
R49,R52	RES,7.87K,1%,1/8W,METAL FILM	R-88-7.87K
R51	RES,2.15K,1%,1/8W,METAL FILM	R-88-2.15K
R53	RES,15.4K,1%,1/8W,METAL FILM	R-88-15.4K

R54	RES,10K,1%,1/8W,METAL FILM	R-88-10K
R55	RES,7.78K,.02%,1/8W,PRECISION THIN FILM	R-365-7.78K
R56	RES,1M,5%,1/4W,COMPOSITION OR FILM	R-76-1M
R57	RES,15K,5%,1/4W,COMPOSITION OR FILM	R-76-15K
R58	RES,5.1K,5%,1/4W,COMPOSITION OR FILM	R-76-5.1K
R59..R62,R65	RES,10K,5%,1/4W,COMPOSITION OR FILM	R-76-10K
R6,R8	RES,5.62K,1%,1/8W,METAL FILM	R-88-5.62K
R63	RES,51.1K,1%,1/8W,METAL FILM	R-88-51.1K
R64	RES,26.7K,1%,1/8W,METAL FILM	R-88-26.7K
R66,R87	RES,1K,5%,1/4W,COMPOSITION OR FILM	R-76-1K
R69	RES,33K,5%,1/4W,COMPOSITION OR FILM	R-76-33K
R7,R9	RES,243,1%,1/8W,METAL FILM	R-88-243
R70	RES,996K,.1%,1/4W,METAL FILM	R-264-996K
R73,R74	RES,15K,10%,2W,COMPOSITION	R-3-15K
R78,R79	RES,4.3K,5%,1/4W,COMPOSITION OR FILM	R-76-4.3K
R80	RES,150,5%,1/4W,COMPOSITION OR FILM	R-76-150
R81,R90	RES,100,5%,1/4W,COMPOSITION OR FILM	R-76-100
R82	RES,NET,1K,2%,1.70W NETWORK	TF-180-3
R85,R86,R89	RES,470,5%,1/4W,COMPOSITION OR FILM	R-76-470
R92	RES,510,5%,1/4W,COMPOSITION OR FILM	R-76-510
R93	RES,270,5%,1/4W,COMPOSITION OR FILM	R-76-270
S1	SWITCH,PUSHBUTTON (6 POLE)	SW-466
S2	SWITCH,SLIDE (DPDT)	SW-476
S3	SWITCH,PUSHBUTTON (2 POLE)	SW-469
T1	TRANSFORMER TRANSFORMER (JAPAN)	TR-261 TR-262
TP1,TP2	CONN,TEST POINT	CS-553
U1	IC,PAL,20L10	IC-643
U12	IC,1Kx8 CMOS DUAL PORT RAM,7130SA100P	LSI-88
U13,U30	IC,32Kx8 STATIC CMOS RAM,D43256C-15L	LSI-76
U14,U28	IC,VERSATILE INTERFACE ADAPTER,G65SC22	LSI-86
U15,U25	IC,8 BIT MICROPROCESSING UNIT,MC68B09	LSI-65
U16	IC,10 INPUT AND INVERT ARRAY,PAL16L8A	IC-582
U17	IC,32Kx8 EPROM,27C256	236-800-*
U18,U19,U58	IC,12 STAGE BINARY COUNTER,74HC4040	IC-407
U21,U40,U46	IC,DUAL 4 BIT COUNTER,74HCT393	IC-462
U23	IC,HEX INVERTER,74HC05	IC-466
U26	IC,10 INPUT AND INVERT ARRAY,PAL16L8	IC-682
U27	IC,GPIB ADAPTER,9914A	LSI-49
U29	IC,NONVOLATILE CONTROLLER DS1210	IC-541
U31	IC,65Kx8 CMOS EPROM ,27C512	236-801-*
U32,U47	IC,QUAD 2 INPUT OR,74HC02	IC-412
U33	IC,PROGRAMMABLE EPROM 2816	LSI-83
U34	IC,OCTAL INTERFACE BUS TRANSCEIVER,75160	IC-298
U35	IC,OCTAL INTERFACE BUS TRANSCEIVER,75161	IC-299
U36	IC,SUPPLY VOLTAGE SUPERVISOR,TL7705AC	IC-602
U38	IC,OCTAL BUFFER,74HC244N	IC-469
U39	IC,1 OF 8 DECODER/DEMULTI,74HC138	IC-431

*Order level of firmware in unit.

U41	IC,DUAL 4 BIT DECADE COUNTER,74HC390	IC-500
U42,U44	IC,8 STAGE SHIFT/STORE REGISTER,4094	IC-251
U43,U52	IC,TRIPLE 2 CH MULTI/DEMUX,4053	IC-283
U45	IC,8 BIT IDENTITY COMP,74HC688	IC-488
U48	IC,LOW POWER OFFSET VOLT QUAD COMP,339	IC-219
U49,U55	IC,DUAL D-TYPE FLIP FLOP,74HC74	IC-337
U50	IC,LOW NOISE OP-AMP,5534	IC-540
U51,U57,U59	IC,HEX INVERTER,74HC04	IC-354
U54	IC,QUAD 2 INPUT NAND,74HC00	IC-351
U56	IC,DUAL LOW NOISE OP-AMP,NE5532	IC-501
VR1	IC,+5V REGULATOR,3A,LM323	IC-240
VR2	IC,+5V VOLTAGE REGULATOR,7805	32469-2
VR3	IC,POS VOLTAGE REG +15V,500mA,78M15	32469-5
VR4	IC,NEG VOLTAGE REG -15V,500mA,79M15	32469-6
VR5	IC,VOLTAGE REGULATOR,LM317MP	IC-308
VR6	IC,VOLTAGE REGULATOR,LM337MP	IC-309
VR7,VR8	DIODE,ZENER,15V,1N4744A	DZ-75
VR9	DIODE,ZENER,68V,IN4760A	DZ-83
W4	JUMPER	J-15
Y1	OSCILLATOR, 8MHZ	CR-25-4
Y2	CRYSTAL,7.68MHZ	CR-29

MODEL 236/237 ANALOG BOARD, PARTS LIST

CIRCUIT DESIG.	DESCRIPTION	KEITHLEY PART NO.
	BOTTOM SHIELD	236-315
	BOTTOM SHIELD INSULATOR	236-323
	CONNECTOR, PINS	CS-276
	INNER SHIELD	236-316
	STANDOFF	ST-137-13
	STANDOFF	ST-139-15
	STANDOFF (#4-40)	ST-137-6
	CONN,TEST POINT	CS-553
	L.E.D. MOUNT	MK-21-1
C101,C102,C115	CAP, 10uF, -20 +100%, 25V, ALUM ELEC	C-314-10
C103..C114, C116..C119	CAP, .1uF, 20%, 50V, CERAMIC	C-365-.1
C12,C16	CAP,22pF,2.5%,630V,POLYPROPYLENE	C-405-22P
C124	CAP,150pF,1%,500V,MICA	C-209-150P
C125,-C128	CAP,68pF,2.5%,630V,POLYPROPYLENE	C-405-68P
C129	CAP,1000pF,10%,1000V,CERAMIC	C-64-1000P
C13,C17,C19,C135	CAP,15pF,5%,100V,CERAMIC	C-372-15P
C130,C140,C141	CAP,1000pF,1%,50V,CERAMIC	C-347-1000P
C131	CAP,47000pF,10%,100V,EPOXY	C-371-47000P
C132	CAP,10pF,10%,1000V,CERAMIC	C-64-10P
C133	CAP,15pF,10%,200V,CERAMIC	C-406-15P
C136,C137	CAP, .1uF, 20%, 50V, CERAMIC	C-365-.1
C138,C139,C159	CAP,5pF,10%,1000V,CERAMIC	C-64-5P
C142,C150..C154	CAP,15pF,5%,100V,CERAMIC	C-372-15P
C143,C144	CAP, 10P, 1%, 100V, CERAMIC	C-372-10P
C145,C146	CAP, .1uF, 20%, 50V, CERAMIC	C-365-.1
C148,C149	CAP,1000pF,1%,50V,CERAMIC	C-347-1000P
C156	CAP, 150P, 1%, 100V, CERAMIC	C-372-150P
C157	CAP,680pF,10%,1000V,CERAMIC	C-64-680P
C158	CAP,470pF,5%,500V,POLYSTYRENE	C-138-470P
C18	CAP,39pF,2%,50V,CERAMIC	C-348-39P
C20	CAP,1500pF,10%,1000V,CERAMIC	C-64-1500P
C21	CAP,270pF,2.5%,630V,POLYPROPYLENE	C-405-270P
C22,C120	CAP,560pF,2.5%,630V,POLYPROPYLENE	C-405-560P
C23	CAP,100pF,2.5%,630V,POLYPROPYLENE	C-405-100P
C24,C121	CAP,220pF,2.5%,630V,POLYPROPYLENE	C-405-220P
C25	CAP,8pF,2.5%,630V,POLYPROPYLENE	C-405-8P
C26,C122,C123	CAP,33pF,2.5%,630V,POLYPROPYLENE	C-405-33P
C28,C37	CAP,.01uF,10%,1000V,CERAMIC	C-64-.01
C2..C5,C35	CAP,.1uF,20%,50V,CERAMIC	C-365-.1
C39	CAP,3300pF,10%,100V,CERAMIC	C-430-3300P
C40,C41,C134	CAP,150pF,1%,100V,CERAMIC	C-372-150P
C43	CAP,1uF,20%,50V,CERAMIC	C-237-1
C44..C48,C55..C7	CAP, .1uF, 20%, 50V, CERAMIC	C-365-.1
C50,C51	CAP,.01uF,20%,50V,CERAMIC	C-365-.01
C54,C76,C98,C155	CAP,10uF,-20+100%,25V,ALUM ELEC	C-314-10
C6	CAP,22pF,10%,1000V,CERAMIC	C-64-22P
C74,C75,C77..C89	CAP, .1uF, 20%, 50V, CERAMIC	C-365-.1
C8	CAP,150pF,10%,1000V,CERAMIC	C-64-150P
C9,C10	CAP,33pF,10%,1000V,CERAMIC	C-64-33P
C91,C93..C95,	CAP, .1uF, 20%, 50V, CERAMIC	C-365-.1

C99,C100

CR19,CR20	DIODE, SILICON, IN4148 (DO-35)	RF-28
CR1..CR4,CR7,	DIODE,IN3595 (DO-7)	RF-43
CR22..CR26,		
CR28..CR33		
CR34	BRIDGE,RECTIFIER,1000V,WL10F	RF-79
CR5,CR6	DIODE,SILICON,SCHOTTKY,BAT42	RF-78
CR9..CR16	DIODE,SILICON,IN4148 (DO-35)	RF-28
J11..J13	CONN,SMB,MALE,P.C. MOUNT	CS-545
J15	CONN,MALE,15 PIN	CS-612-15
J19	CONN,DUAL 7-PIN-BERG	CS-389-5
J27	CONN,CONTACT PIN	TE-110
K1,K3	RELAY,REED, HI VOLTAGE	RL-129
K2,K4..K7	RELAY,REED, HI VOLTAGE	RL-119
K8..K12,K15	RELAY (SPST)	RL-117
P8	CONNECTOR,MOLEX (10-PIN)	CS-287-10
P18	CONNECTOR, MOLEX (3 PIN) (FOR P18 ASS'Y) GROMMET	CS-287-3 GR-6
Q18	SELECTION, TG-167	236-601
Q19,Q31	TRANS,NPN SILICON,2N3904 (TO-92)	TG-47
Q24	TRANS,N CHANNEL JFET,SELECTED J210	TG-167
Q25..Q28	TRANS,NPN COMP SILICON AMP,2N5089	TG-62
Q29	TRANS,PNP SILICON,2N3906 (TO-92)	TG-84
Q32,Q43,Q44,Q46,	TRANS,CURRENT REGULATOR,CR430	TG-219
Q48		
Q35,Q37,Q38,Q4,	TRANS,SELECTED N CHANNEL JFET,5434	TG-179
Q5		
Q36	TRANS,CURRENT REGULATOR,CR120	TG-159
Q39,Q40	TRANS,N-CHANNEL FET	TG-128
Q41,Q42,Q45,Q47	TRANS,NPN CATV SILICON,MPSH17	TG-221
Q49,Q50	TRANS,N-CHANNEL JFET	TG-198
Q6,Q7,Q10..Q14,	TRANS,SELECTED N CHANNEL JFET,5434	TG-179
Q33		
Q8,Q9	TRANS,P CHANNEL JFET,J270 (TO-92)	TG-166
R100,R114,R127	RES,100K,5%,1/4W,COMPOSITION OR FILM	R-76-100K
R101	RES,12.4K,1%,1/8W,METAL FILM	R-88-12.4K
R102	RES,820K,5%,1/4W,COMPOSITION OR FILM	R-76-820K
R103,R106,R109	RES,180K,5%,1/4W,COMPOSITION OR FILM	R-76-180K
R104	RES,91K,5%,1/4W,COMPOSITION OR FILM	R-76-91K
R107	RES,1.5M,5%,1/4W,COMPOSITION OR FILM	R-76-1.5M
R110	RES,300K,5%,1/4W,COMPOSITION OR FILM	R-76-300K
R115	RES,200K,5%,1/4W,COMPOSITION OR FILM	R-76-200K
R119	RES,4.99K,1%,1/8W,METAL FILM	R-88-4.99K
R120..R122	RES, 10K, 5%, 1/4W, COMPOSITION OR FILM	R-76-10K
R12	RES,10G,2%,1.5W,HY MEG	R-289-10G
R125	RES,75K,1%,1/8W,METAL FILM	R-88-75K
R126,R137	RES,100,1%,1/8W,METAL FILM	R-88-100
R128	RES,681,.1%,1/10W,METAL FILM	R-263-681
R129..R131	RES,732K,1%,1/4W,PRECISION THIN FILM	R-368-732K
R13,R29,R62,R63	RES,10K,.1%,1/10W,METAL FILM	R-263-10K
R132,R166	RES,51K,5%,1/4W,COMPOSITION OR FILM	R-76-51K
R133	RES,10.101K,.1%.75W,WIREWOUND	R-384-10.101K

R134,R135	RES,100K,10%,1/2W,COMPOSITION	R-1-100K
R136	RES, 10K, 5%, 1/4W, COMPOSITION OR FILM	R-76-10K
R138	RES,22K,10%,1/2W,COMPOSITION	R-1-22K
R139..R146	RES,794,.1%,1/10W,METAL FILM	R-263-794
R14	RES,2.77K,.1%,1/10W,METAL FILM	R-377-2.77K
R147	RES,27.4K,.1%,1/10W,METAL FILM	R-377-27.4K
R148,R149	RES, 10K, 1%, 1/8W, METAL FILM	R-88-10K
R15	RES,300K,.1%,1/10W,METAL FILM	R-377-300K
R150	RES,5.1K,5%,1/4W,COMPOSITION OR FILM	R-76-5.1K
R152,R154	RES,4.7M,5%,1/4W,COMPOSITION OR FILM	R-76-4.7M
R155	RES,10K,.1%,1/10W,METAL FILM	R-263-10K
R156	RES,137K,1%,1/8W,METAL FILM	R-88-137K
R159,R168	RES,100K,5%,1/4W,COMPOSITION OR FILM	R-76-100K
R160,R161	RES,10K,10%,1/2W,COMPOSITION	R-1-10K
R162	RES, 1K, 5%, 1/4W, COMPOSITION OR FILM	R-76-1K
R163	RES,2K,5%,1/4W,COMPOSITION OR FILM	R-76-2K
R164,R165	RES,3.9K,5%,1/4W,COMPOSITION OR FILM	R-76-3.9K
R167	RES,56.2K,1%,1/8W,METAL FILM	R-88-56.2K
R169	RES,510,5%,1/4W/COMPOSITION OR FILM	R-76-510
R16..R18	RES,1M,0.1%,1/4W,METAL FILM	R-374-1M
R170	RES,250,.1%,1/10W,WIREWOUND	R-291-250
R2	RES,10K,10%,1W,COMPOSITION	R-2-10K
R20,R22	RES,13K,5%,1/4W,COMPOSITION OR FILM	R-76-13K
R25,R31..R35,R49	RES,560K,5%,1/4W,COMPOSITION OR FILM	R-76-560K
R26,R27,R30	RES,100K,.1%,1/10W,METAL FILM	R-263-100K
R28	RES,49.9,1%,1/8W,COMPOSITION OR	R-88-49.9
R3,R21,R23,R24	RES,10.101K,.1%.75W,WIREWOUND	R-384-10.101K
R38	RES,998K,.1%,1/4W,METAL FILM	R-264-998K
R39	RES,9.88M,0.5%,1/2W,1200V,METAL OR FILM	R-265-9.88M
R4	RES,5.6K,5%,1/4W,COMPOSITION OR FILM	R-76-5.6K
R40	RES,1G,2%,1.5W,HY MEG	R-289-1G
R41	RES,100M,1%,1.5W,HY MEG	R-289-100M
R43,R54,R83,R84	RES,10K,1%,1/8W,METAL FILM	R-88-10K
R44	RES,90K,.1%,1/10W,METAL FILM	R-377-90K
R45,R56,R57,R72	RES,10K,.1%,1/10W,METAL FILM	R-377-10K
R46	RES,15K,5%,1/4W,COMPOSITION OR FILM	R-76-15K
R47,R48,R116..	RES,10K,5%,1/4W,COMPOSITION OR FILM	R-76-10K
R118		
R5,R6,R9,R42	RES,1K,5%,1/4W,COMPOSITION OR FILM	R-76-1K
R50,R52,R53,R66	RES,20K,5%,1/4W,COMPOSITION OR FILM	R-76-20K
R51	RES,243K,5%,1/4W,COMPOSITION OR	R-88-243K
R55,R82	RES,150,5%,1/4W,COMPOSITION OR FILM	R-76-150
R58,R67	RES,1.1M,5%,1/4W,COMPOSITION OR FILM	R-76-1.1M
R61	RES,8.2M,5%,1/4W,COMPOSITION OR FILM	R-76-8.2M
R68,R123,R124	RES,1K,5%,1/4W,COMPOSITION OR FILM	R-76-1K
R7	RES,51,5%,1/4W,COMPOSITION OR FILM	R-76-51
R71,R105,R108	RES,20K,5%,1/4W,COMPOSITION OR FILM	R-76-20K
R73,R79,R80	RES,10K,.1%,1/10W,METAL FILM	R-377-10K
R74,R75,R153	RES, 10K, .1%, 1/10W, METAL FILM	R-263-10K
R76	RES,SELECTED,1%,1/8W,METAL FILM	R-88-*
R77	RES,4.5K,.1%,1/10W,METAL FILM	R-263-4.5K
R78	RES,7.39K,.1%,1/10W,METAL FILM	R-263-7.39K
R8,R157	RES,49.9K 1%,1/8W,METAL FILM	R-88-49.9K
R85,R151	RES,19.6K,1%,1/8W,METAL FILM	R-88-19.6K
R86,R87	RES,100K,.1%,1/10W,METAL FILM	R-377-100K
R89	RES,11.1K,.1%,1/10W,METAL FILM	R-377-11.1K
R92,R94	RES,2.2K,5%,1/4W,COMPOSITION OR FILM	R-76-2.2K
R93,R95	RES,3.57K,5%,1/4W,COMPOSITION OR	R-88-3.57K

R96	RES,1.24K,1%,1/8W,METAL FILM	R-88-1.24K
R97	RES,82K,5%,1/4W,COMPOSITION OR FILM	R-76-82K
R98	RES,18K,5%,1/4W,COMPOSITION OR FILM	R-76-18K
TE10,TE12,TE14, TE16..TE19, TE2 TE3,TE6..TE8, TE22..TE29 TE20,TE21	TERMINAL (TEFLON)	TE-97-1
	TERMINAL (TEFLON)	TE-91
U1,U45,U48	IC,SPST CMOS ANALOG SWITCH,5052(DG211)	IC-320
U10,U31	IC,LOW POWER OFFSET VOLT QUAD COMP,339	IC-219
U11	IC,WIDEBAND CURRENT BUFFER,LH4001	IC-572
U18	IC,22V OP-AMP,OP-07	IC-207
U19,U47	IC,20V OP-AMP,LT1055CN8	IC-672
U2,U3	IC,OP-AMP,AD542	IC-542
U23,U25	IC,14-BIT CMOS D/A CONVERTER,AD7538KN	IC-601
U26,U28,U29,U35	IC,8 STAGE SHIFT/STORE REGISTER,4094	IC-251
U30	IC,QUAD 2-1 LINE DATA SEL/MULT,74HC158	IC-587
U32	IC,QUAD LOW POWER JFET,LF444	IC-329
U33	IC,QUAD 2 INPUT POS AND,74HC08	IC-465
U34	IC,DUAL D-TYPE FLIP FLOP,74HC74	IC-337
U37	IC,DARLINGTON ARRAY,2003	IC-206
U38	IC,3 TO 8 LINE DECODER/DEMULTI,74HC138	IC-431
U4,U8,U13,U14, U17,U41..U43	IC,18V BIFET OP-AMP,AD744KN	IC-586
U44	IC,RETRIGGERABLE MONO MULTIVIB,74HC123	IC-492
U46	IC,OCTAL BUFFER,74HC244N	IC-469
U49	IC,SPST CMOS ANALOG SWITCH,DG271	IC-508
U5,U7,U21,U22, U24, U50	IC,15V OP-AMP,1007	IC-422
U6	IC,CMOS SERIAL INPUT 12-BIT DAC,MP7543	IC-419
U9,U12,U15	IC,DUAL HIGH SPEED OP-AMP,LT1057ACN8	IC-590
VR1,VR6	DIODE,ZENER,15V,1N4744	DZ-75
VR11	DIODE,ZENER 6.4V,1N4579	DZ-73
VR14,VR15	DIODE,ZENER 200V,1N5388A	DZ-74
VR2,VR5	DIODE,ZENER 4.3V,1N749A	DZ-63
VR3,VR4	DIODE,ZENER 12V,1N963B	DZ-54
VR9,VR10	DIODE,ZENER 15V,1N718	DZ-18

MODEL 236 OUTPUT MODULE, PARTS LIST

CIRCUIT DESIG.	DESCRIPTION	KEITHLEY PART NO.
	CLAMP	236-308
	CONNECTOR PINS	CS-236
	CONNECTOR PINS	CS-276
	HEAT SINK	236-306
	OUTPUT SHROUD	236-312
	STANDOFF	ST-151-15
	STANDOFF	ST-151-17
C10,C12	CAP,3300pF,5%,500V,DIPPED MICA	C-236-3300P
C17,C19	CAP,.01uF,10%,1000V,CERAMIC	C-64-.01
C20	CAP,.01uF,20%,50V,CERAMIC	C-365-.01
C9,C13..C15	CAP,1100pF,5%,500V,DIPPED MICA	C-236-1100P
CR7,CR9	DIODE,SILICON,1N4148 (DO-35)	RF-28
CR8,CR10..CR12	DIODE,SILICON,1N4937	RF-71
P15	CONNECTOR, HOUSING	CS-638-15
P16	CONNECTOR, HOUSING	CS-287-4
Q1,Q2	TRANS,N-CHANNEL FET,2N7000	TG-195
Q18,Q23	TRANS,N-CHANNEL FET,IRF630	TG-214
Q19,Q25	TRANS,PNP POWER,MJE350	TG-210
Q21,Q24	TRANS,NPN SILICON,MJE340	TG-209
Q27	TRANS,PNP SILICON,2N3906 (TO-92)	TG-84
Q7,Q8	TRANS,P-CHANNEL 200V FET,IRF9630	TG-215
Q9,Q20,Q22,Q26, Q28	TRANS,NPN SILICON,2N3904 (TO-92)	TG-47
R1,R2	RES,158,1%,1/8W,METAL FILM	R-88-158
R18,R19	RES,1.1M,5%,1/4W,COMPOSITION OR FILM	R-76-1.1M
R20,R34,R36,R39	RES,3.3M,5%,1/4W,COMPOSITION OR FILM	R-76-3.3M
R21,R22,R23,R28	RES,51,5%,1/4W,COMPOSITION OR FILM	R-76-51
R24,R26	RES,26.1,1%,1/8W,METAL FILM	R-88-26.1
R25,R27	RES,619,1%,1/8W,METAL FILM	R-88-619
R29,R30	RES,27.4,1%,1/8W,METAL FILM	R-88-27.4
R31,R32	RES,11.3K,1%,1/8W,METAL FILM	R-88-11.3K
R37,R38	RES,51,5%,1/4W,COMPOSITION OR FILM	R-76-51
VR1,VR2	DIODE,ZENER 6.44V,1N4577AGED (DO-7)	DZ-58
W1..W6	JUMPER	J-15

MODEL 237 OUTPUT MODULE, PARTS LIST

CIRCUIT DESIG.	DESCRIPTION	KEITHLEY PART NO.
	CLAMP	236-308
	CONNECTOR PINS	CS-236
	CONNECTOR PINS	CS-276
	HEAT SINK	236-306
	OUTPUT SHROUD	236-312
	STANDOFF	ST-151-17
	STANDOFF	ST-151-15
C10,C12	CAP,1800pF,1%,500V,DIPPED MICA	C-209-1800P
C16,C18	CAP,.01,20%,2000V,CERAMIC	C-324-.01
C17,C19	CAP,.01uF,10%,1000V,CERAMIC	C-64-.01
C1..C3,C5	CAP,1100pF,5%,500V,DIPPED MICA	C-236-1100P
C20	CAP,.01,20%,50V,CERAMIC	C-365-.01
C4,C6	CAP,2200pF,1%,500V.DIPPED MICA	C-278-2200P
C7..C9,C13..C15	CAP,1100pF,5%,500V,DIPPED MICA	C-236-1100P
CR1,CR2,CR4,CR6, CR10..CR16	DIODE,HIGH VOLTAGE,HV-15 (B CASE)	RF-76
CR3,CR5,CR8	DIODE,SILICON,1N4937	RF-71
CR7,CR9	DIODE,SILICON,1N4148 (DO-35)	RF-28
P15	CONNECTOR, HOUSING	CS-638-15
P16	CONNECTOR, HOUSING	CS-287-4
P17	CONNECTOR, HOUSING	CS-287-5
Q1,Q2	TRANS,N-CHANNEL FET,2N7000	TG-195
Q10,Q19,Q25	TRANS,PNP POWER,MJE350	TG-210
Q11,Q14	TRANS,NPN COMP SILICON AMP,MPS8099	TG-157
Q15,Q18,Q23	TRANS,N-CHANNEL FET,MTP2N50	TG-206
Q16,Q21,Q24	TRANS,NPN SILICON,MJE340	TG-209
Q20,Q22,Q26,Q28	TRANS,NPN SILICON,2N3904 (TO-92)	TG-47
Q27	TRANS,PNP SILICON,2N3906 (TO-92)	TG-84
Q29,Q31	TRANS,NPN SILICON,2N3904 (TO-92)	TG-47
Q3,Q4,Q7,Q8,Q12	TRANS,P-CHANNEL FET,MTP2P50	TG-208
Q30,Q32	TRANS,N-CHANNEL FET,MTP2N50	TG-206
Q5,Q6,Q9,Q13,Q17	TRANS,NPN SILICON,2N3904 (TO-92)	TG-47
R1,R2	RES,158,1%,1/8W,METAL FILM	R-88-158
R10,R12	RES,10K,5%,1/4W,COMPOSITION OR FILM	R-76-10K
R13,R33	RES,1.8M,5%,1/4W,COMPOSITION OR FILM	R-76-1.8M
R18,R19	RES,2.2M,5%,1/4W,COMPOSITION OR FILM	R-76-2.2M
R21..R23,R28,R35	RES,51,5%,1/4W,COMPOSITION OR FILM	R-76-51
R24,R26	RES,26.1,1%,1/8W,METAL FILM	R-88-26.1
R25,R27	RES,619,1%,1/8W,METAL FILM	R-88-619
R29,R30	RES,27.4,1%,1/8W,METAL FILM	R-88-27.4
R31,R32	RES,11.3K,1%,1/8W,METAL FILM	R-88-11.3K
R36,R39	RES,3.3M,10%,1/2W,COMPOSITION	R-1-3.3M
R37,R38,R40	RES,51,5%,1/4W,COMPOSITION OR FILM	R-76-51
R3..R6,R15,R17	RES,51,5%,1/4W,COMPOSITION OR FILM	R-76-51
R7,R8,R14,R16	RES,3.3M,10%,1W,COMPOSITION	R-2-3.3M
R9,R11,R20,R34	RES,3.3M,10%,1/2W,COMPOSITION	R-1-3.3M
VR1,VR2	DIODE,ZENER 6.44V,1N4577AGED (DO-7)	DZ-58

MODEL 237 RESONANT CONVERTER, PARTS LIST

CIRCUIT DESIG.	DESCRIPTION	KEITHLEY PART NO.
	CONNECTOR PINS CONN,MALE,5 PIN	CS-276 CS-288-5
C1	CAP,10uF,-20+100%,25V,ALUM ELEC	C-314-10
C11,C20,C21,C23	CAP,.01uF,10%,1000V,CERAMIC	C-64-.01
C13	CAP,470pF,10%,1000V,CERAMIC	C-64-470P
C15..C18	CAP,.1uF,20%,50V,CERAMIC	C-365-.1
C19,C24	CAP,1000pF,10%,1000V,CERAMIC	C-64-1000P
C2,C3,C5,C12	CAP,1uF,20%,50V,CERAMIC	C-237-1
C22	CAP,330uF,20%,63V,ALUM ELEC	C-412-330
C25	CAP,.22uF,5%,160V,POLYPROPYLENE	C-391-.22
C26..C33	CAP,10uF,20%,350V,ALUM ELEC	C-393-10
C34..C37	CAP,4.7uF,20%,350V,ALUM ELEC	C-393-4.7
C38..C41	CAP,2.2uF,20%,350V,ALUM ELEC	C-393-2.2
C4,C6,C10,	CAP,.1uF,20%,50V,CERAMIC	C-365-.1
C42..C45	CAP,.01uF,20%,2000V,CERAMIC	C-324-.01
C46	CAP,1uF,20%,100V,CERAMIC	C-420-1
C7..C9,C14	CAP,1000pF,1%,50V,CERAMIC	C-347-1000P
CR1..CR4	DIODE,SCHOTTKY,1N5711	RF-69
CR5,CR6	DIODE,SILICON,IN4148 (DO-35)	RF-28
CR7,CR8	DIODE,SILICON,SCHOTTKY,SB160	RF-70
CR9..CR26	DIODE,SILICON,1N4937 FOR P23 KEY (MOLEX)	RF-71 CS-345
J17	MODIFIED CONNECTOR	590-314-5
L1	CHOKE,1000uH	CH-37-1
L2	CHOKE	CH-46
L3	CHOKE,10uH	CH-39-1
P23	CONNECTOR, HOUSING	CS-287-6
Q1,Q2	TRANS,N CHANNEL FET,IRF530	TG-184
Q3,Q4	TRANS,NPN,2N5089,(TO-92)	TG-62
Q5..Q7	TRANS,PNP,2N5087 (TO-92)	TG-61
R1	RES,243,1%,1/8W,METAL FILM	R-88-243
R11	RES,44.2K,1%,1/8W,METAL FILM	R-88-44.2K
R13	RES,5.62M,1%,1/2W,350VMAX,METAL FILM	R-36-5.62M
R14	RES,63.4K,1%,1/8W,METAL FILM	R-88-63.4K
R15	RES,40.2K,1%,1/8W,METAL FILM	R-88-40.2K
R16	RES,150,5%,1/4W,COMPOSITION OR FILM	R-76-150
R17,R19,R21,R29	RES,1K,5%,1/4W,COMPOSITION OR FILM	R-76-1K
R18,R20	RES,22,5%,1/4W,COMPOSITION OR FILM	R-76-22
R2	RES,2.67K,1%,1/8W,METAL FILM	R-88-2.67K
R22,R28	RES,180K,5%,1/4W,COMPOSITION OR FILM	R-76-180K
R23,R30	RES,100K,5%,1/4W,COMPOSITION OR FILM	R-76-100K
R24,R26	RES,30M,10%,1/2W,1.5KV,METAL OXIDE	R-367-30M
R25,R27	RES,2.2M,10%,1/2W,1.5KV,METAL OXIDE	R-367-2.2M
R3	RES,4.32K,1%,1/8W,METAL FILM	R-88-4.32K
R31	POT,10K,10%,.5W,NON-WIREWOUND	RP-97-10K

R4,R8	RES,15K,1%,1/8W,METAL FILM	R-88-15K
R5	RES,10K,5%,1/4W,COMPOSITION OR FILM	R-76-10K
R6,R12	RES,4.7M,5%,1/4W,COMPOSITION OR FILM	R-76-4.7M
R7,R10	RES,2K,1%,1/8W,METAL FILM	R-88-2K
R9	RES,26.7K,1%,1/8W,METAL FILM	R-88-26.7K
T1	TRANSFORMER	TR-205
T2	TRANSFORMER	TR-257
TP1,TP2	CONN,TEST POINT	CS-553
U1,U5	IC,RETRIGGERABLE MONO MULTIVIB,74HC123	IC-492
U2	IC,DUAL POWER MOSFET DRIVER,TSC426	IC-437
U3	IC,VOLTAGE REGULATOR,LM317T	IC-317
U4	IC,18V OP-AMP,TLC271	IC-347
U6	IC,VAR POS VOLTAGE REG,100mA,78L05A	IC-223
VR2	DIODE,ZENER 20V,1N4747A (DO-41)	DZ-25
VR3	DIODE,ZENER 6.44V,1N4577 AGED (DO-7)	DZ-58
VR4,VR6,VR8	DIODE,ZENER 5.1V,1N751 (DO-7)	DZ-59
VR5,VR7	DIODE,ZENER 24V,1N723 (DO-7)	DZ-17

MODEL 236/237 MISCELLANEOUS, PARTS LIST

CIRCUIT DESIG.	DESCRIPTION	KEITHLEY PART NO.
	HIGH VOLTAGE BOTTOM SHIELD (237)	237-304
	MODIFIED PRINTED CIRCUIT SUPPORT STANDOFF	228-314-2
	STANDOFF (#6 CLEARANCE)	ST-151-16
	SUPPORT, PRINTED CIRCUIT BOARD	ST-196-1
	TOP COVER, RESONANT CONVERTER (237)	228-318
	FAN	237-305
	FILTER	FN-25
	FRONT PANEL	FL-9
	KNOB	236-304
	LINE CORD	236-305
	OVERLAY, FRONT PANEL (236)	CO-7
	REAR FOOT	236-303
	REAR PANEL	FE-21
	STANDOFF	236-309
	STANDOFF (#4-40)	ST-151-18
	SUPPORT, PRINTED CIRCUIT BOARD	ST-173-1
	TOP SHIELD, ANALOG BOARD	228-318
	WINDOW (RED)	236-37
	INTERLOCK CABLE (3M)	236-314-1
	TRIAx TO TRIAX CABLE	236-ILC-3
	TOP COVER	7078-TRX-3
	DECORATIVE STRIP ASSEMBLY	236-324
	BOTTOM COVER	193-323
	DECORATIVE STRIP ASSEMBLY	228-313
	FRONT FOOT ASSEMBLY	193-322
	TRIAx, BNC'S CAP, PROTECTIVE	706-317
	SIDE PANEL ASSEMBLY	CAP-30-1
	FRONT BEZEL ASSEMBLY	193-310
	FAN MTG. ISO-MOUNT	228-303
		SH-4
J1, J2	CABLE ASS'Y (TRIAx, RIGHT ANGLE SMB)	CA-72-2
J26, J26	CONNECTOR, 3 PIN MALE	CS-659
J3	CABLE ASS'Y (TRIAx, RIGHT ANGLE SMB)	CA-72-1
J4	BINDING POST (BLACK)	BP-11-0
J5	BINDING POST (METAL)	BP-15
J6, J7	CONNECTOR, BNC	CS-249
J9	A.C. LINE FILTER	LF-2
P20	CONNECTOR HOUSING (5 PIN MOLEX)	CS-287-5
P21	CONNECTOR HOUSING (10 PIN MOLEX)	CS-287-10
P22	CONNECTOR (3 PIN MOLEX)	CS-287-3
P27	CONNECTOR (BERG)	CS-627

011-922 .ON

LTR.	ECCO NO.	REVISION	ENG.	DATE
B	13084	RELEASED	SZ	11/11/88
C	13155	REVISED	SZ	2/10/89
D	13324	REVISED:ARTWORK WAS REV. C	SZ	5/19/89
E	13981	CHG'D ARTWORK REV FROM D TO E.	SZ	3/14/90

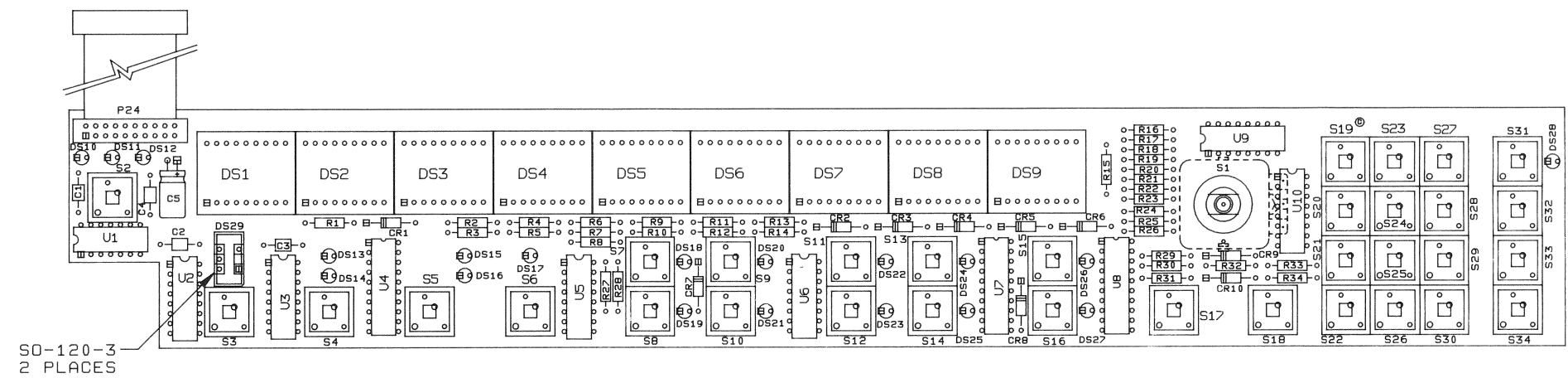

PUSHBUTTON SELECTION CHART

SCHEMATIC DESIGNATION	PART NUMBER
228-317-4	S2
228-317-5	S3 THRU S6
228-317-6	S7 THRU S16
228-317-7	S17 THRU S34

NOTE: INSTALL MK-22-1 UNDER ALL PL-71 (DS10-28)

NOTE: FOR MORE COMPONENT INFORMATION REFER TO BILL OF MATERIAL 236-000-02

MODEL	NEXT ASSEMBLY	QTY.
237		1
236		1
USED ON		

DO NOT SCALE THIS DRAWING	DIMENSIONAL TOLERANCES UNLESS OTHERWISE SPECIFIED	DATE 9/27/87	SCALE 1:1	TITLE
KEITHLEY KEITHLEY INSTRUMENTS INC. CLEVELAND, OHIO 44139	XX=±.015 ANG.=±1°	DRN. MH	ENG. APPR. JGB	COMPONENT LAYOUT, DISPLAY BOARD
	XXX=±.005 FRAC.=±1/64 SURFACE MAX. 63	MATERIAL	FINISH	
				NO. 236-110

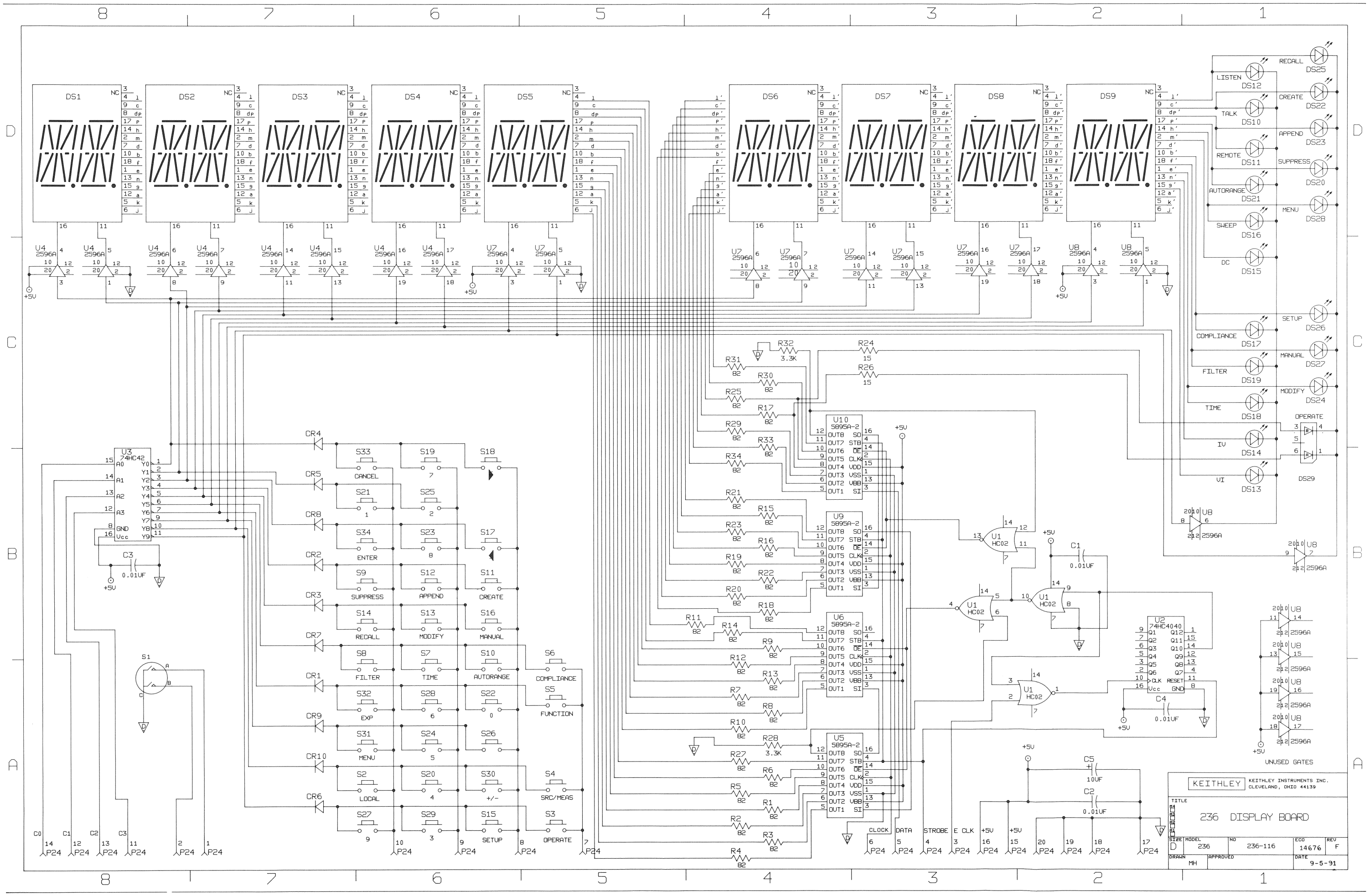

KEITHLEY KEITHLEY INSTRUMENTS INC. CLEVELAND, OHIO 44139			
TITLE 236 DISPLAY BOARD			
SIZE MODEL D 236	NO 236-116	ECO 14676	REV F
DRAWN MH	APPROVED	DATE	9-5-91

001-9220 .ON

LTR.	ECC NO.	REVISION	ENG.	DATE
C	13084	REVISED	SZ	11-11-88
D	13190	REVISED	SZ	2-15-89
E	13384	ART. HAS REV. D, ADDED C116, R91, R92 AND NOTE #6.	AS	6-26-89
E1	13647	ADDED R93	AS	8-30-89
F	13813	CHG'D ARTWORK REV FROM E TO F ADDED CR28, R93 MOUNTED ON BOARD/DELETED NOTE AND C117, RELOCATED R49.	AS	3-9-90
G	14070	CHG'D ARTWORK REV FROM F TO G	AS	7-23-90

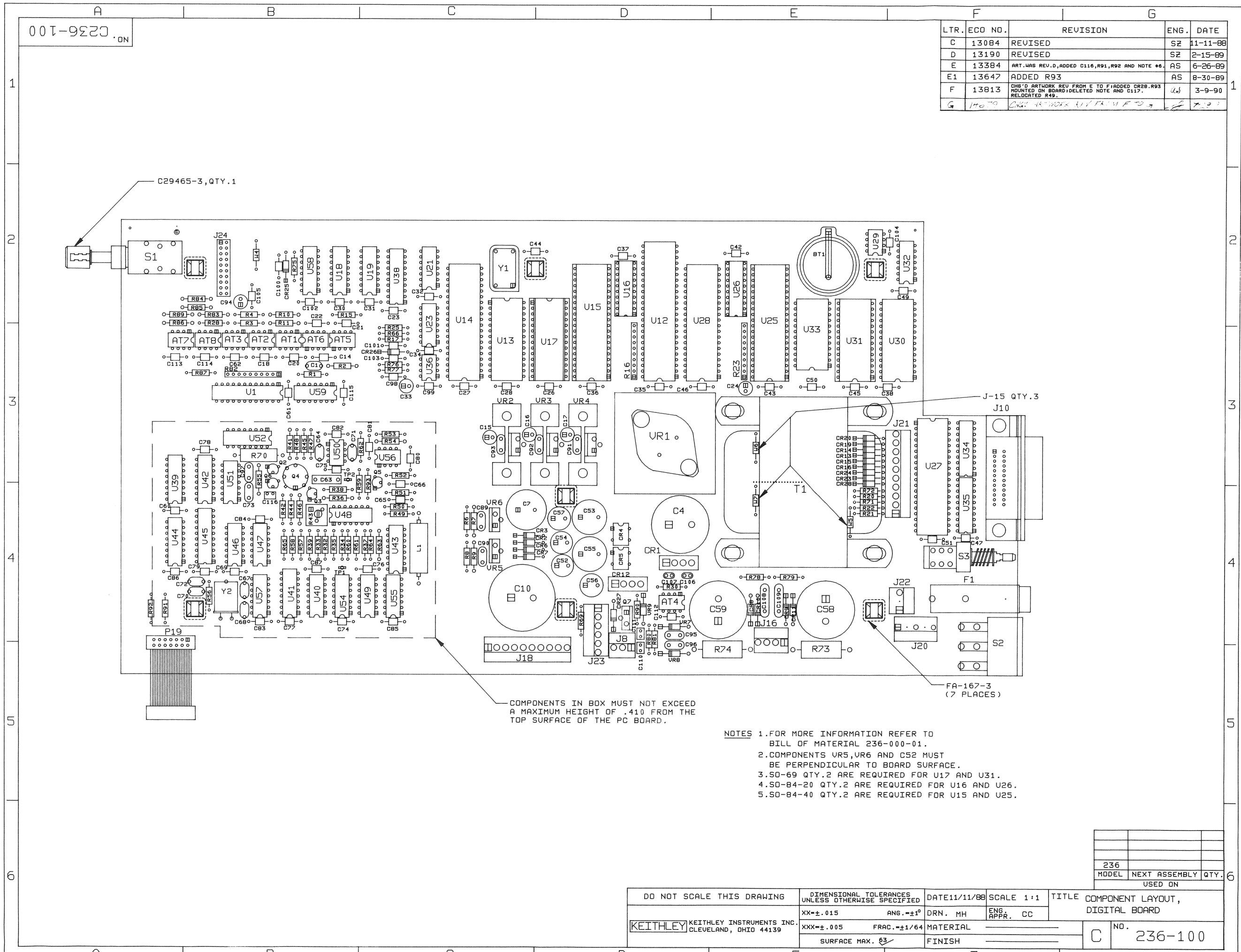

COMPONENTS IN BOX MUST NOT EXCEED A MAXIMUM HEIGHT OF .410 FROM THE TOP SURFACE OF THE PC BOARD.

- NOTES
1. FOR MORE INFORMATION REFER TO BILL OF MATERIAL 236-000-01.
 2. COMPONENTS VR5, VR6 AND C52 MUST BE PERPENDICULAR TO BOARD SURFACE.
 3. SO-69 QTY. 2 ARE REQUIRED FOR U17 AND U31.
 4. SO-84-20 QTY. 2 ARE REQUIRED FOR U16 AND U26.
 5. SO-84-40 QTY. 2 ARE REQUIRED FOR U15 AND U25.

236		
MODEL	NEXT ASSEMBLY	QTY.
		6

DO NOT SCALE THIS DRAWING	DIMENSIONAL TOLERANCES UNLESS OTHERWISE SPECIFIED	DATE 11/11/88	SCALE 1:1	TITLE COMPONENT LAYOUT, DIGITAL BOARD
KEITHLEY KEITHLEY INSTRUMENTS INC. CLEVELAND, OHIO 44139	XX=±.015 ANG.=±1° XXX=±.005 FRAC.=±1/64 SURFACE MAX. .03	DRN. MH	ENG. CC	
		MATERIAL		NO. 236-100
		FINISH		

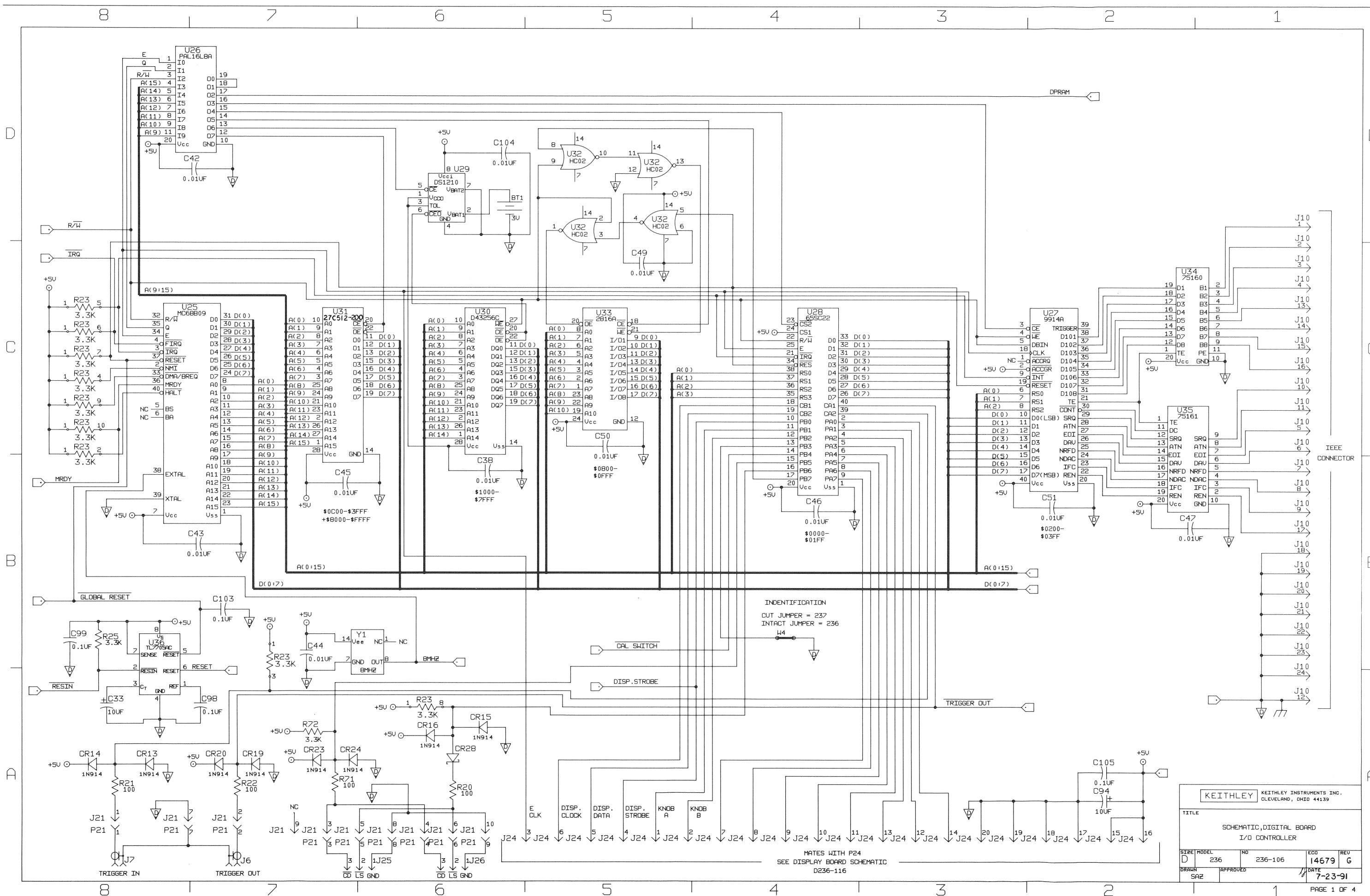

MATES WITH P24
SEE DISPLAY BOARD SCHEMATIC
D236-116

KEITHLEY		KEITHLEY INSTRUMENTS INC. CLEVELAND, OHIO 44139	
TITLE			
SCHEMATIC, DIGITAL BOARD I/O CONTROLLER			
SIZE	MODEL	NO	ECO
D	236	236-106	14679
DRWN	SAZ	APPROVED	DATE
			7-23-91
		REV	G
		DATE	7-23-91

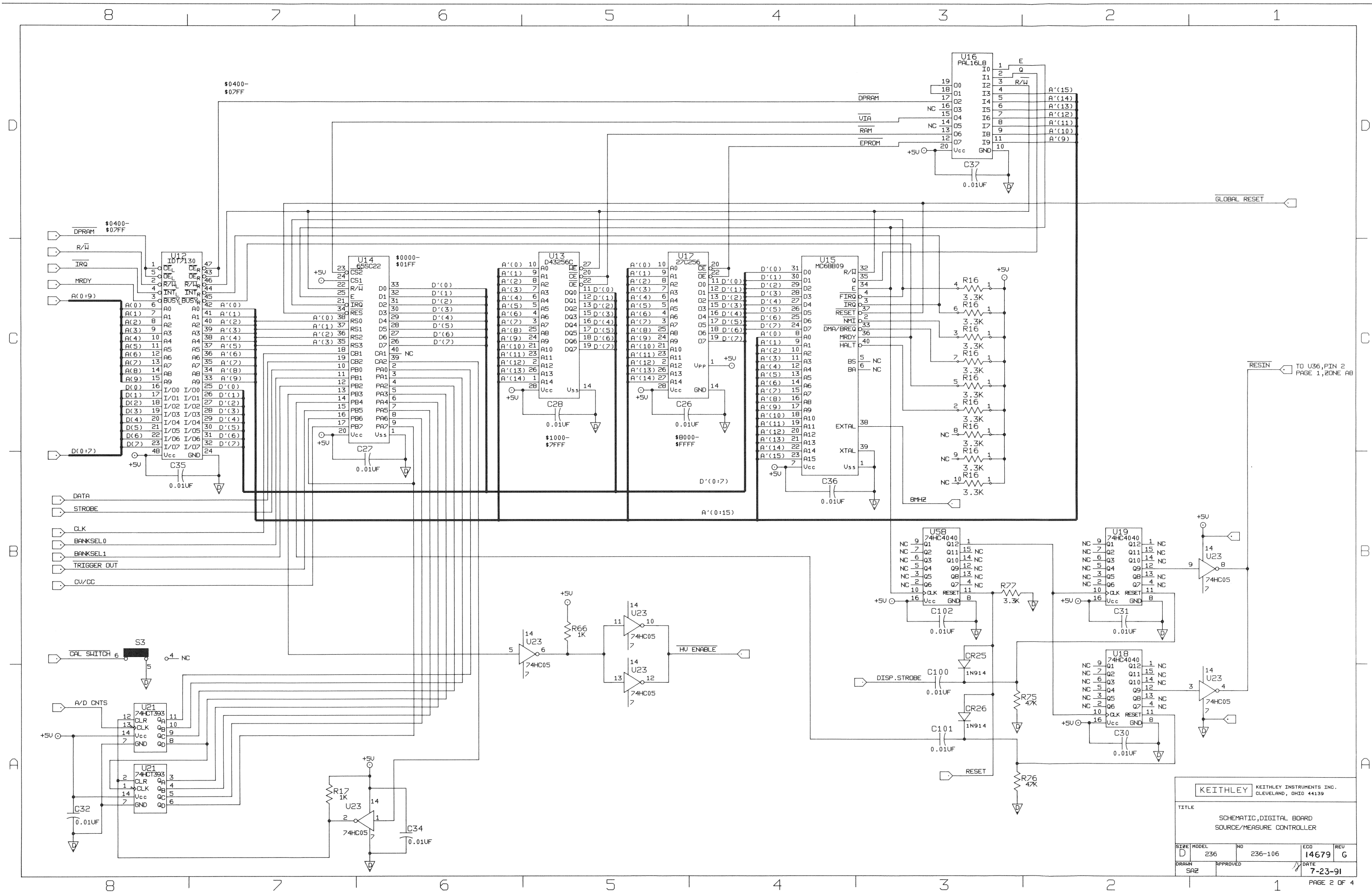

KEITHLEY KEITHLEY INSTRUMENTS INC. CLEVELAND, OHIO 44139			
TITLE SCHEMATIC, DIGITAL BOARD SOURCE/MEASURE CONTROLLER			
SIZE	MODEL	NO	EGG
D	236	236-106	14679
DRWN	SAZ	APPROVED	DATE
			7-23-91
			PAGE 2 OF 4

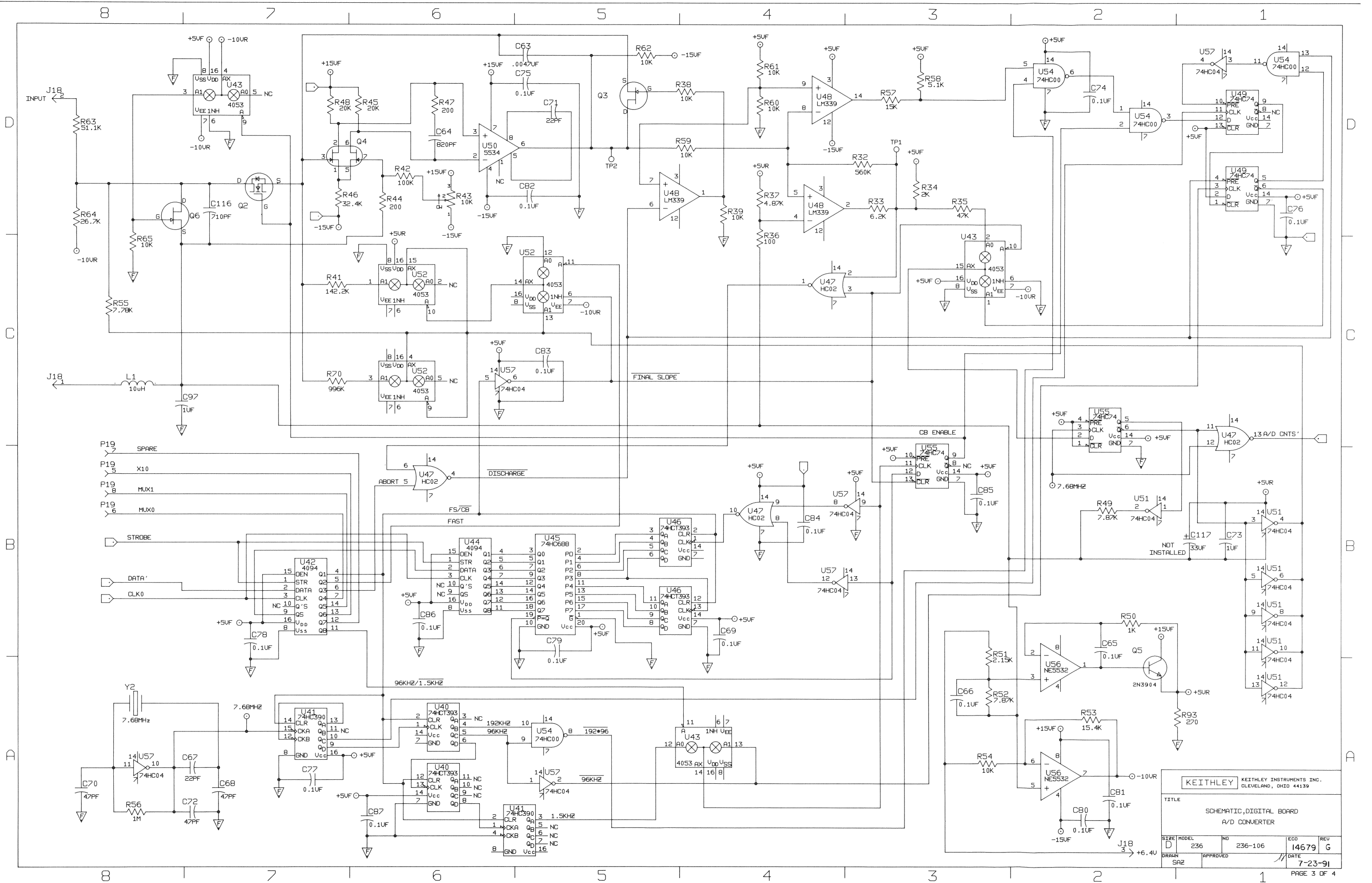

KEITHLEY KEITHLEY INSTRUMENTS INC. CLEVELAND, OHIO 44139			
TITLE SCHEMATIC, DIGITAL BOARD A/D CONVERTER			
SIZE D	MODEL 236	NO 236-106	ECD 14679
DRAWN SAZ	APPROVED	DATE 7-23-91	REV G
PAGE 3 OF 4			

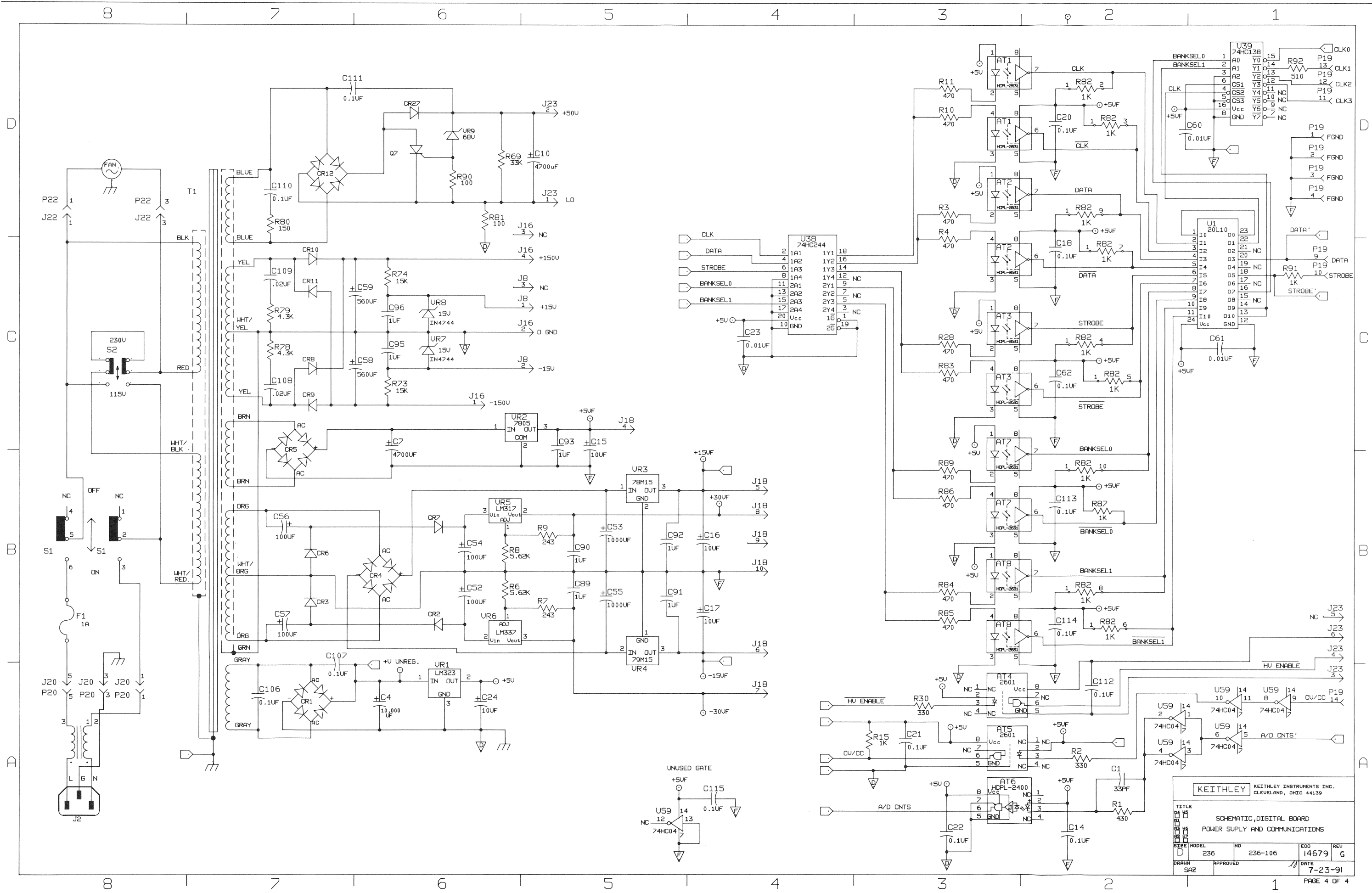

KEITHLEY KEITHLEY INSTRUMENTS INC. CLEVELAND, OHIO 44139			
TITLE	SCHEMATIC, DIGITAL BOARD POWER SUPPLY AND COMMUNICATIONS		
SIZE	MODEL	NO	ECO
D	236	236-106	14679
DRW	SAZ	APPROVED	DATE
			7-23-91
			PAGE 4 OF 4

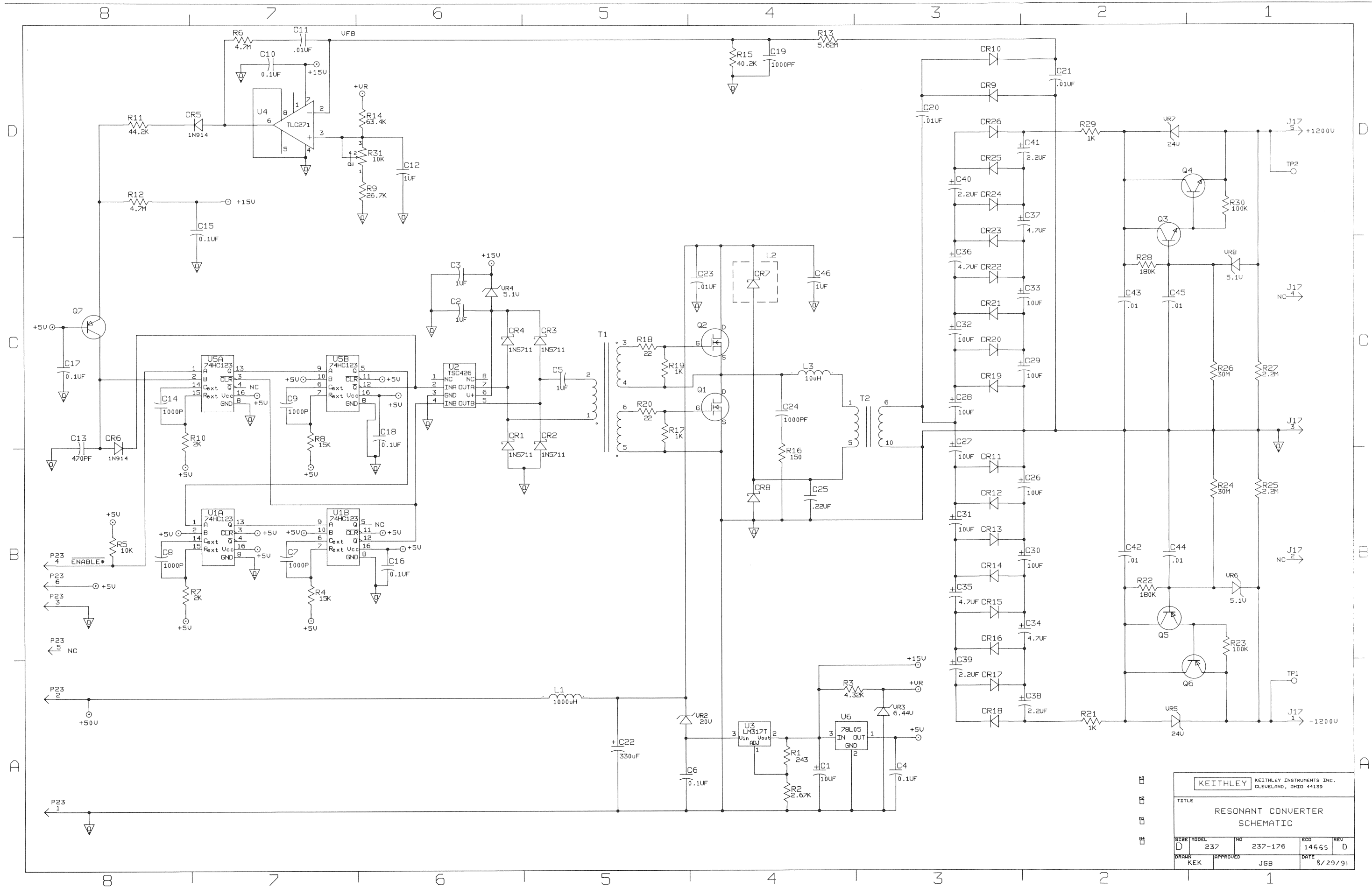

KEITHLEY KEITHLEY INSTRUMENTS INC. CLEVELAND, OHIO 44139				
TITLE RESONANT CONVERTER SCHEMATIC				
SIZE	MODEL	NO	ECO	REV
D	237	237-176	14665	D
DRAWN	APPROVED	DATE		
KEK	JGB	8/29/91		

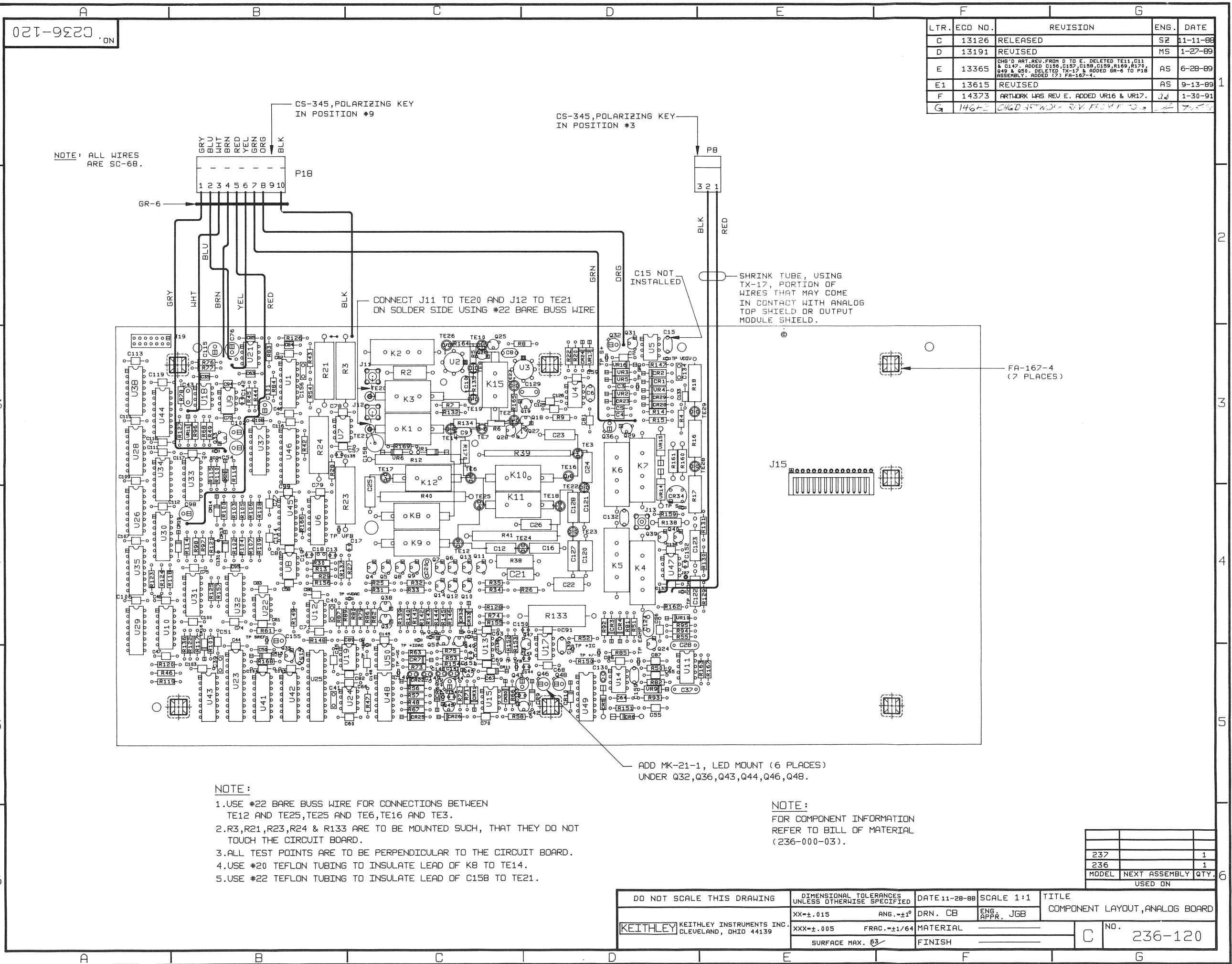

021-9220 ON

LTR.	ECO NO.	REVISION	ENG.	DATE
C	13126	RELEASED	SZ	11-11-88
D	13191	REVISED	MS	1-27-89
E	13365	CHG'D ART. REV. FROM D TO E. DELETED TE11, C11 & C147. ADDED C156, C157, C158, C159, R169, R170, Q49 & Q50. DELETED TX-17 & ADDED GR-6 TO P18 ASSEMBLY. ADDED 173 FA-167-4.	AS	6-28-89
E1	13615	REVISED	AS	9-13-89
F	14373	ARTWORK WAS REV E. ADDED UR16 & UR17.	AS	1-30-91
G	14642	CHG'D ART. WORK. REV. FROM F TO G.	AS	7-2-91

NOTE: ALL WIRES ARE SC-68.

NOTE:

1. USE #22 BARE BUSS WIRE FOR CONNECTIONS BETWEEN TE12 AND TE25, TE25 AND TE6, TE16 AND TE3.
2. R3, R21, R23, R24 & R133 ARE TO BE MOUNTED SUCH, THAT THEY DO NOT TOUCH THE CIRCUIT BOARD.
3. ALL TEST POINTS ARE TO BE PERPENDICULAR TO THE CIRCUIT BOARD.
4. USE #20 TEFLON TUBING TO INSULATE LEAD OF K8 TO TE14.
5. USE #22 TEFLON TUBING TO INSULATE LEAD OF C158 TO TE21.

NOTE:
FOR COMPONENT INFORMATION REFER TO BILL OF MATERIAL (236-000-03).

ADD MK-21-1, LED MOUNT (6 PLACES) UNDER Q32, Q36, Q43, Q44, Q46, Q48.

SHRINK TUBE, USING TX-17, PORTION OF WIRES THAT MAY COME IN CONTACT WITH ANALOG TOP SHIELD OR OUTPUT MODULE SHIELD.

FA-167-4 (7 PLACES)

MODEL	NEXT ASSEMBLY	QTY.
237		1
236		1
USED ON		

DO NOT SCALE THIS DRAWING	DIMENSIONAL TOLERANCES UNLESS OTHERWISE SPECIFIED	DATE 11-28-88	SCALE 1:1	TITLE
KEITHLEY KEITHLEY INSTRUMENTS INC. CLEVELAND, OHIO 44139	XX=±.015 ANG.=±1° XXX=±.005 FRAC.=±1/64 SURFACE MAX. 63	DRN. CB	ENG. APPR. JGB	COMPONENT LAYOUT, ANALOG BOARD
				NO. 236-120

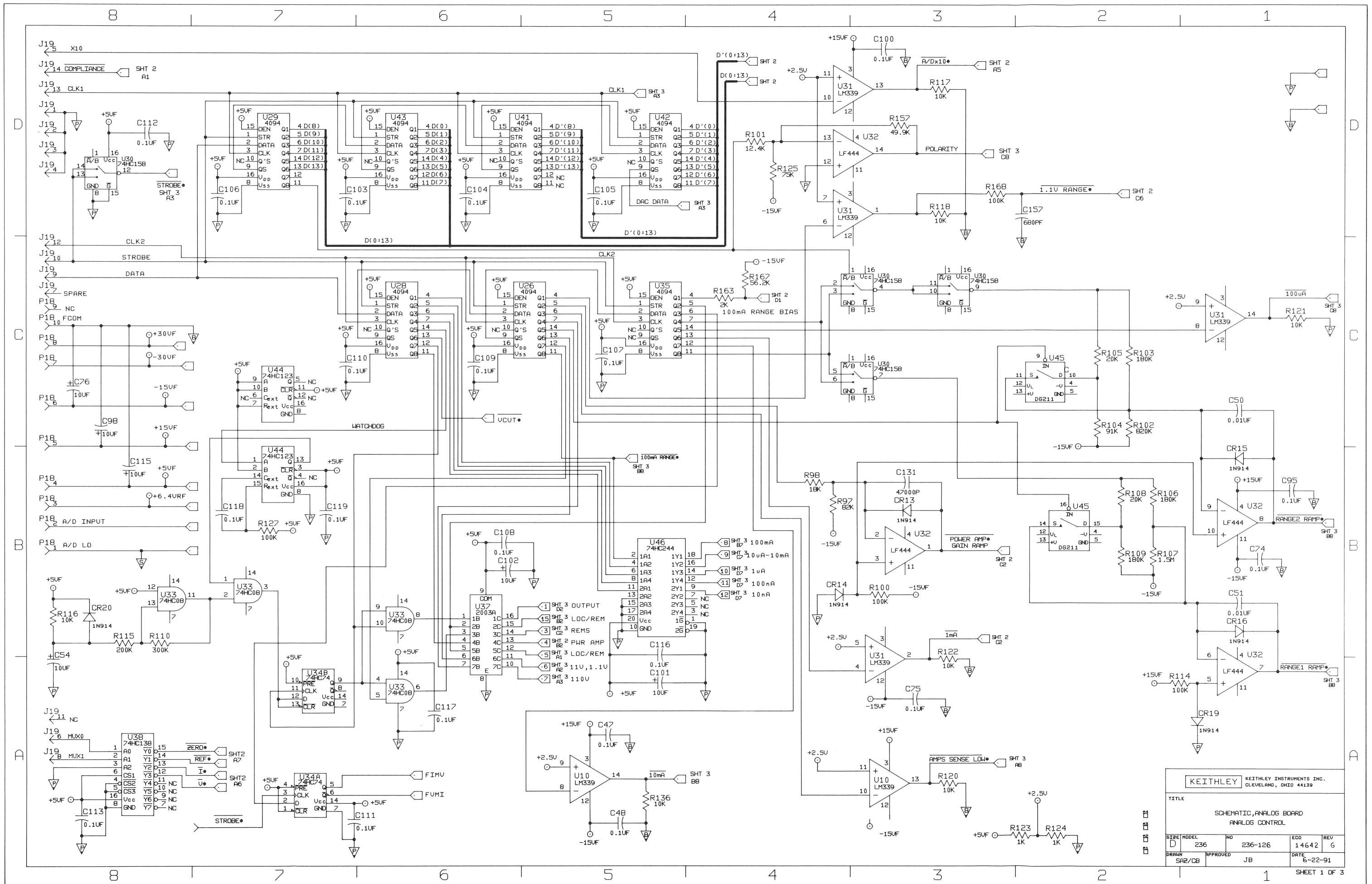

KEITHLEY		KEITHLEY INSTRUMENTS INC. CLEVELAND, OHIO 44139	
TITLE			
SCHEMATIC, ANALOG BOARD ANALOG CONTROL			
SIZE	MODEL	NO	ECO
D	236	236-126	14642
DRWN	APPROVED	DATE	REV
SAZ/CB	JB	6-22-91	6
			SHEET 1 OF 3

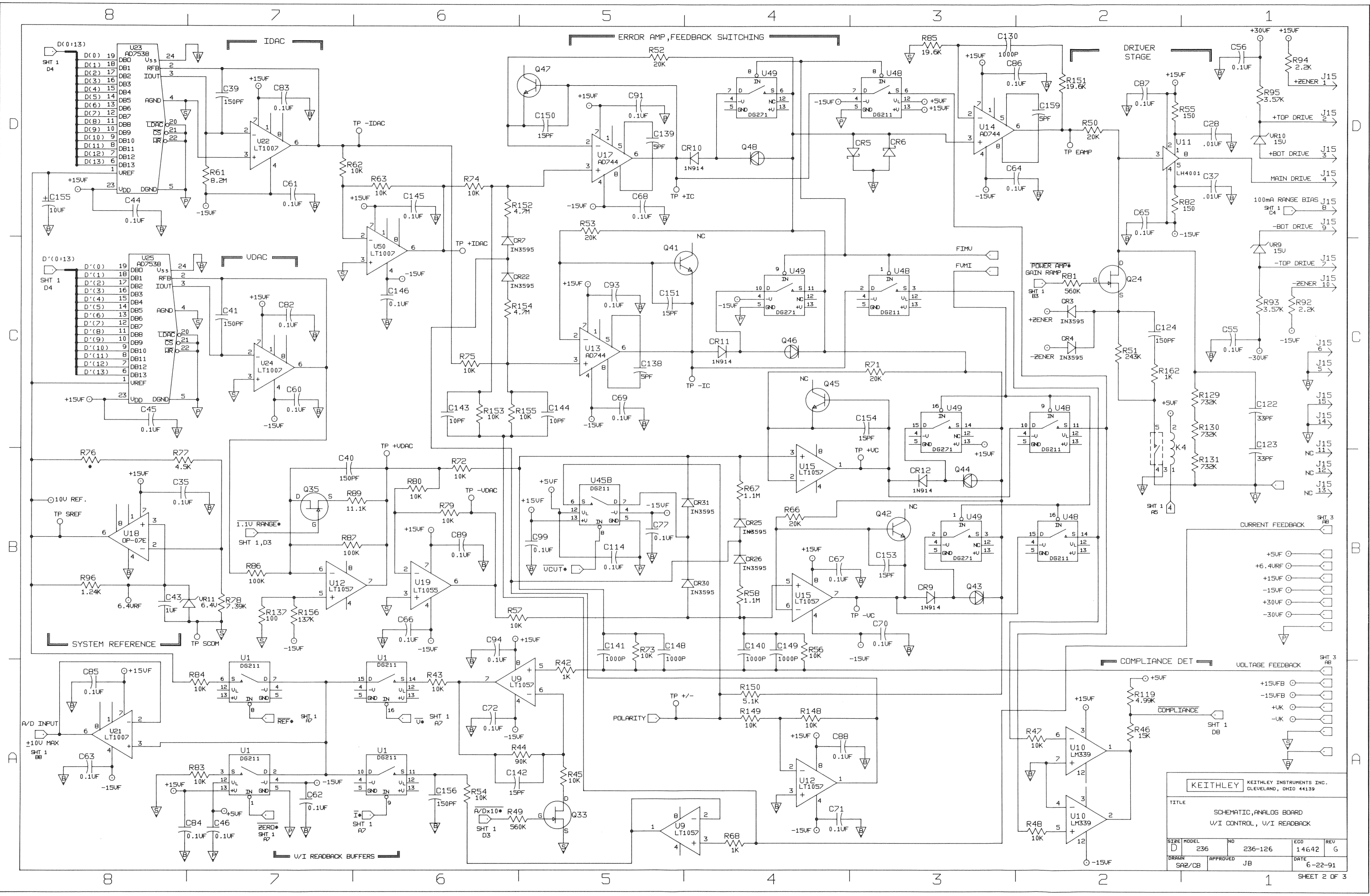

KEITHLEY KEITHLEY INSTRUMENTS INC. CLEVELAND, OHIO 44139					
TITLE SCHEMATIC, ANALOG BOARD W/I CONTROL, W/I READBACK					
SIZE	MODEL	NO	EGD	REV	
D	236	236-126	14642	G	
DRAWN	APPROVED	DATE			
SAZ/CB	JB	6-22-91			
					SHEET 2 OF 3

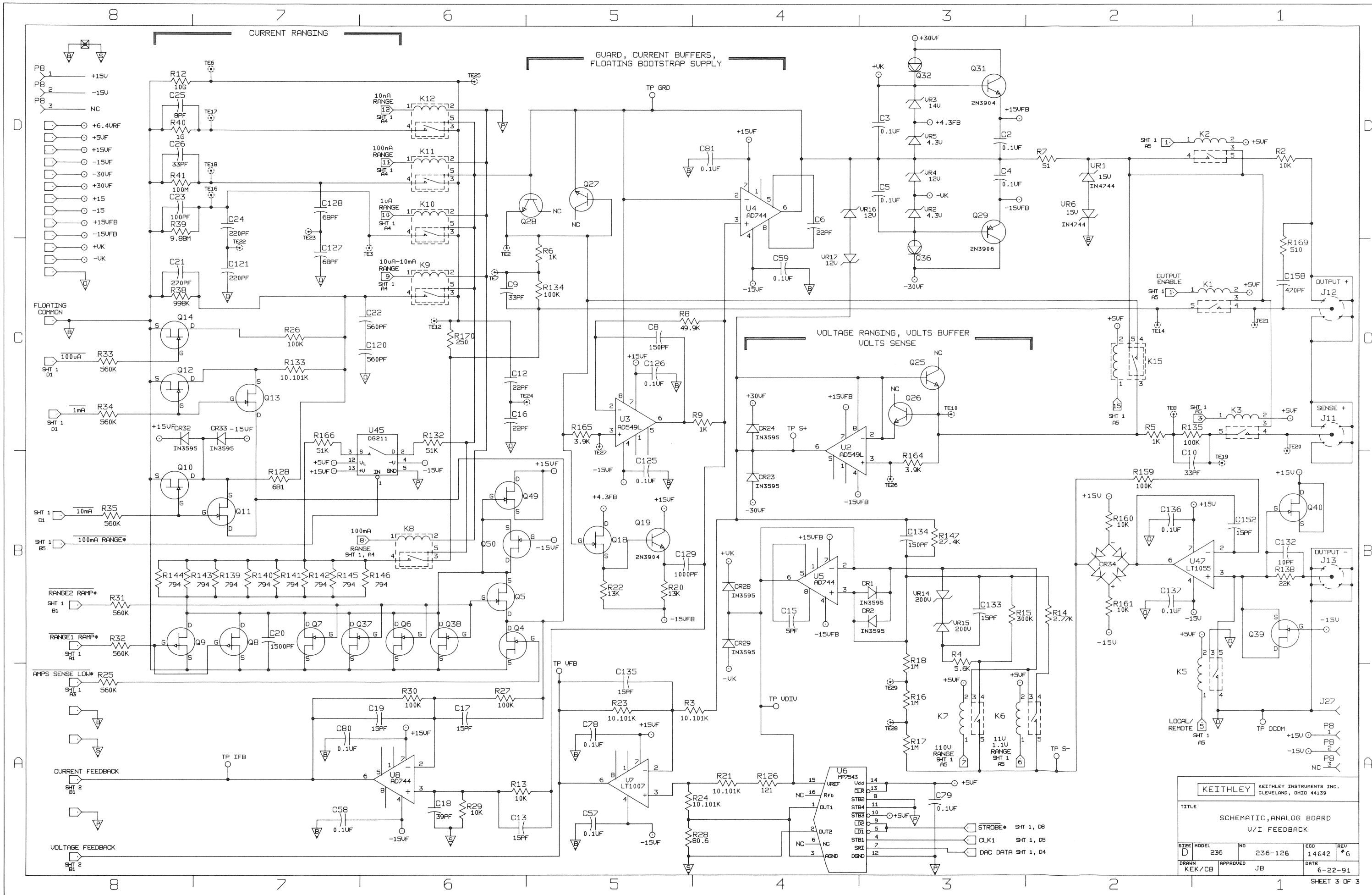

KEITHLEY KEITHLEY INSTRUMENTS INC. CLEVELAND, OHIO 44139			
TITLE SCHEMATIC, ANALOG BOARD U/I FEEDBACK			
SIZE D	MODEL 236	NO 236-126	EGD 14642
DRAWN KEK/CB	APPROVED JB	DATE 6-22-91	REV *6

091-952
ON

LTR.	ECO NO.	REVISION	ENG.	DATE
C	13084	RELEASED	SZ	11/11/88
D	13155	REVISED	SZ	2/14/89
D1	13385	CHG'D FROM TX-17 TO BR-6 ON P16 ASSEM.	SZ	7/26/89

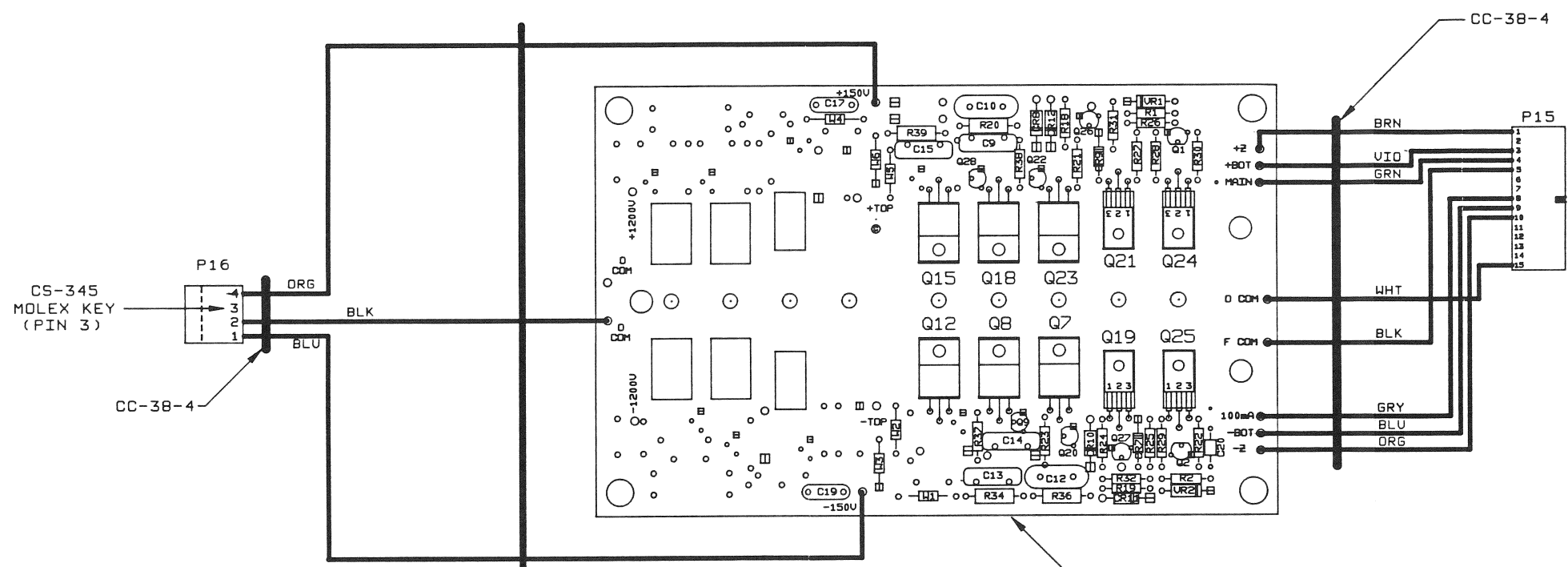

GR-6 (GROMMET)
ADD TO PORTION OF
ASSEMBLY THAT CAN
CONTACT SHIELDS

NOTE: ALL WIRES ARE SC-68.

NOTE:
FOR COMPONENT INFORMATION,
REFER TO BILL OF MATERIAL
(236-000-04).

MODEL	NEXT ASSEMBLY	QTY.	USED ON
236			

DO NOT SCALE THIS DRAWING	DIMENSIONAL TOLERANCES UNLESS OTHERWISE SPECIFIED	DATE 1/29/88	SCALE 1:1	TITLE COMPONENT LAYOUT OUTPUT BOARD
XX=±.015	ANG.=±1°	DRN. KEK	ENG. APPR. JGB	
XXX=±.005	FRAC.=±1/64	MATERIAL		
SURFACE MAX. 3	FINISH			
				NO. 236-160

8 7 6 5 4 3 2 1

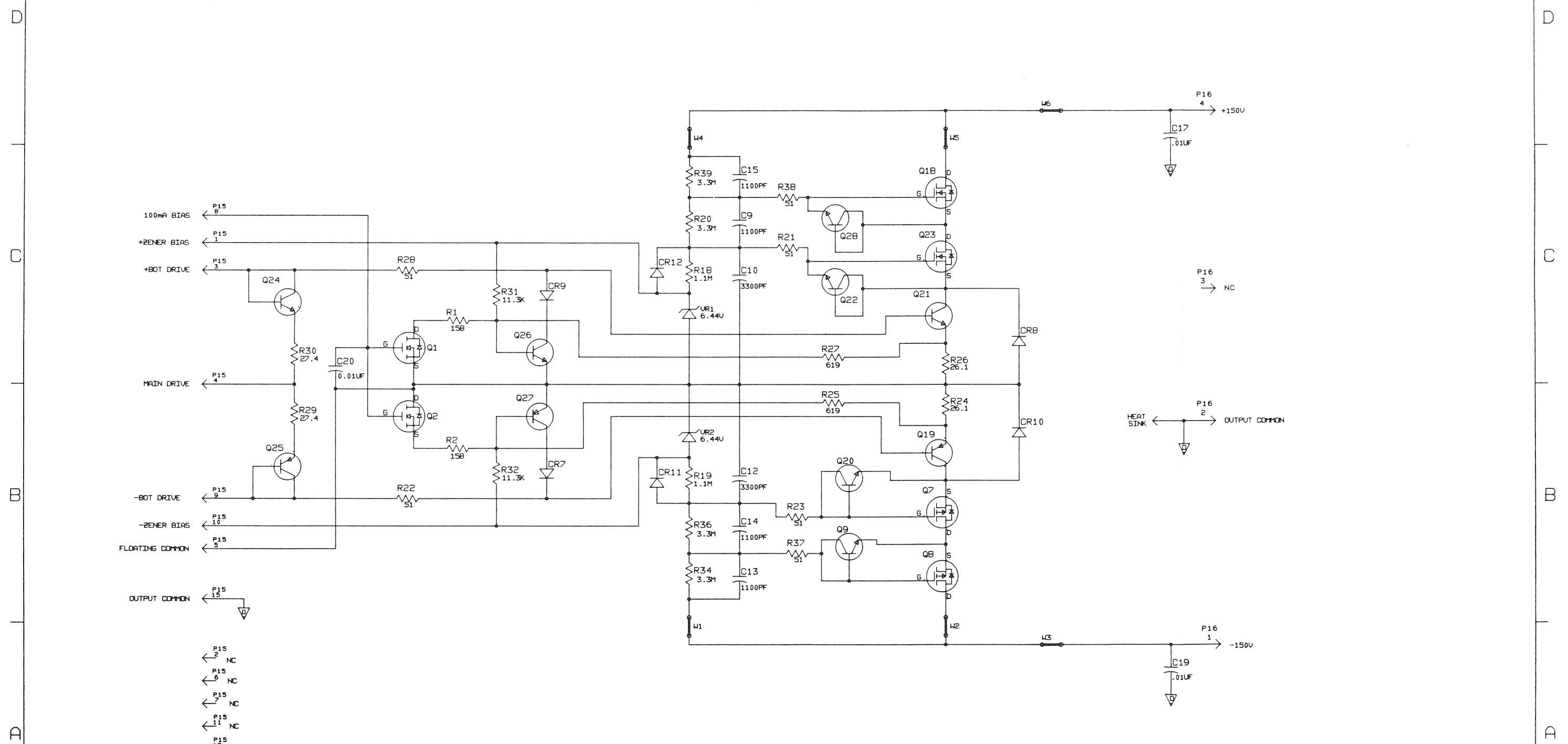

- 100mA BIAS ← P15 8
- +ZENER BIAS ← P15 1
- +BOT DRIVE ← P15 3
- MAIN DRIVE ← P15 4
- BOT DRIVE ← P15 9
- ZENER BIAS ← P15 10
- FLOATING COMMON ← P15 5
- OUTPUT COMMON ← P15 15
- P15 2 NC ←
- P15 6 NC ←
- P15 7 NC ←
- P15 11 NC ←
- P15 12 NC ←
- P15 13 NC ←
- P15 14 NC ←

- P16 4 → +150V
- P16 3 → NC
- HEAT SINK ← P16 2 → OUTPUT COMMON
- P16 1 → -150V

KEITHLEY		KEITHLEY INSTRUMENTS INC.	
CLEVELAND, OHIO 44139			
TITLE			
SCHEMATIC			
236 OUTPUT MODULE			
SIZE	MODEL	NO	EGG
D	236	236-166	13155
DATE	DATE	DATE	DATE
2/1/89	2/1/89	2/1/89	2/1/89
DRAWN		APPROVED	
KEK		<i>JOB</i>	

8 7 6 5 4 3 2 1

091-222
ON

LTR.	ECO NO.	REVISION	ENG.	DATE
C	13084	RELEASED		11/11/88
D	13155	REVISED	SZ	2/14/89
D1	13385	CHG. D. FROM TX-17 TO GR-6 ON P16 & P17 ASSEMBLIES.		7/26/89

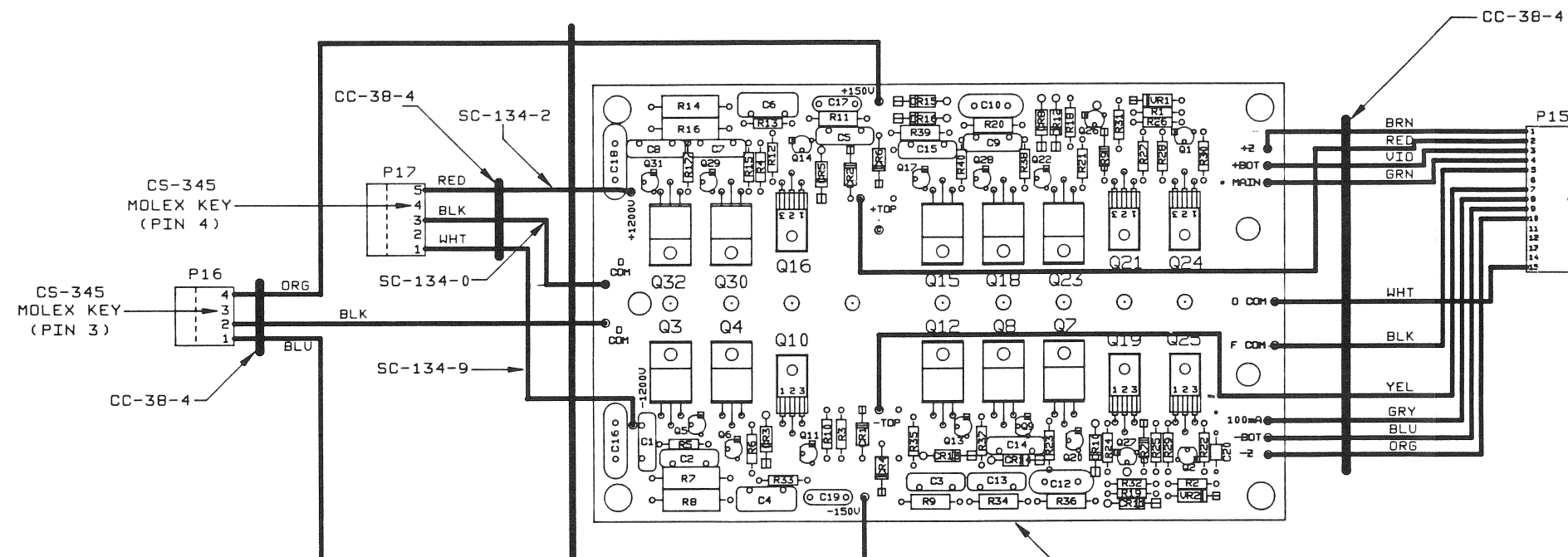

NOTE:
FOR COMPONENT INFORMATION,
REFER TO BILL OF MATERIAL
(237-000-04).

NOTE: ALL WIRES ARE SC-68, UNLESS OTHERWISE SPECIFIED.

GR-6 (GROMMET)
ADDED TO PORTION OF
ASSEMBLY THAT CAN
CONTACT SHIELDS

236-162

MODEL	NEXT ASSEMBLY	QTY.
237		

DO NOT SCALE THIS DRAWING	DIMENSIONAL TOLERANCES UNLESS OTHERWISE SPECIFIED	DATE 1/29/88	SCALE 1:1	TITLE	COMPONENT LAYOUT OUTPUT BOARD
KEITHLEY KEITHLEY INSTRUMENTS INC. CLEVELAND, OHIO 44139	XX=±.015 ANG.=±1° XXX=±.005 FRAC.=±1/64 SURFACE MAX. 63	DRN. KEK	ENG. APPR. JGB		
		MATERIAL		C	NO. 237-160
		FINISH			

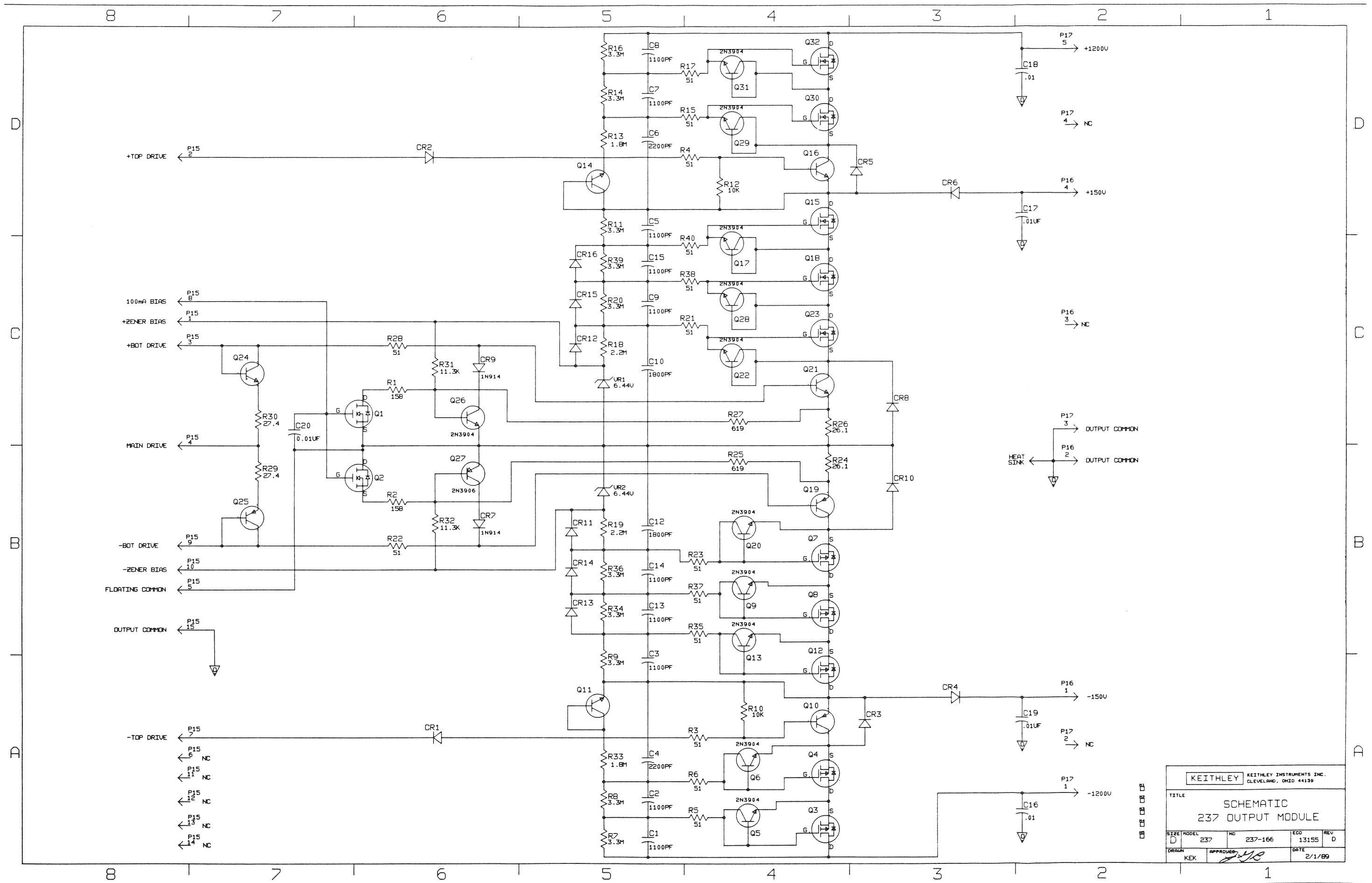

+TOP DRIVE ← P15 2
 100mA BIAS ← P15 8
 +ZENER BIAS ← P15 1
 +BOT DRIVE ← P15 3
 MAIN DRIVE ← P15 4
 -BOT DRIVE ← P15 9
 -ZENER BIAS ← P15 10
 FLOATING COMMON ← P15 5
 OUTPUT COMMON ← P15 15
 -TOP DRIVE ← P15 7
 ← P15 6 NC
 ← P15 11 NC
 ← P15 12 NC
 ← P15 13 NC
 ← P15 14 NC

P17 3 OUTPUT COMMON
 P16 2 OUTPUT COMMON
 HEAT SINK
 P17 1 -1200V
 P17 2 NC
 P16 1 -150V
 P17 5 +1200V
 P17 4 NC
 P16 4 +150V

KEITHLEY KEITHLEY INSTRUMENTS INC. CLEVELAND, OHIO 44139			
TITLE SCHEMATIC 237 OUTPUT MODULE			
SIZE D	MODEL 237	NO 237-166	ECO 13155
DRAWN KEK	APPROVED <i>[Signature]</i>	DATE 2/1/89	REV D

021-222 .ON

LTR.	ECO NO.	REVISION	ENG.	DATE
B	13084	RELEASED	MS	11/11/88
C	13155	REVISED	SZ	2/14/89
D	14665	ARTWORK WAS REV C		9/11/91

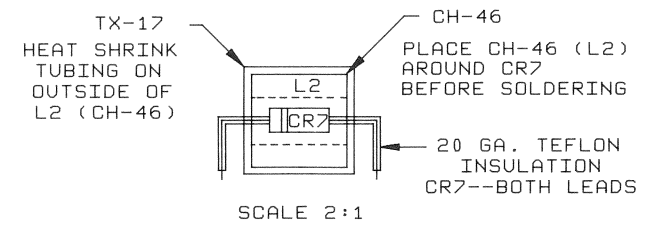
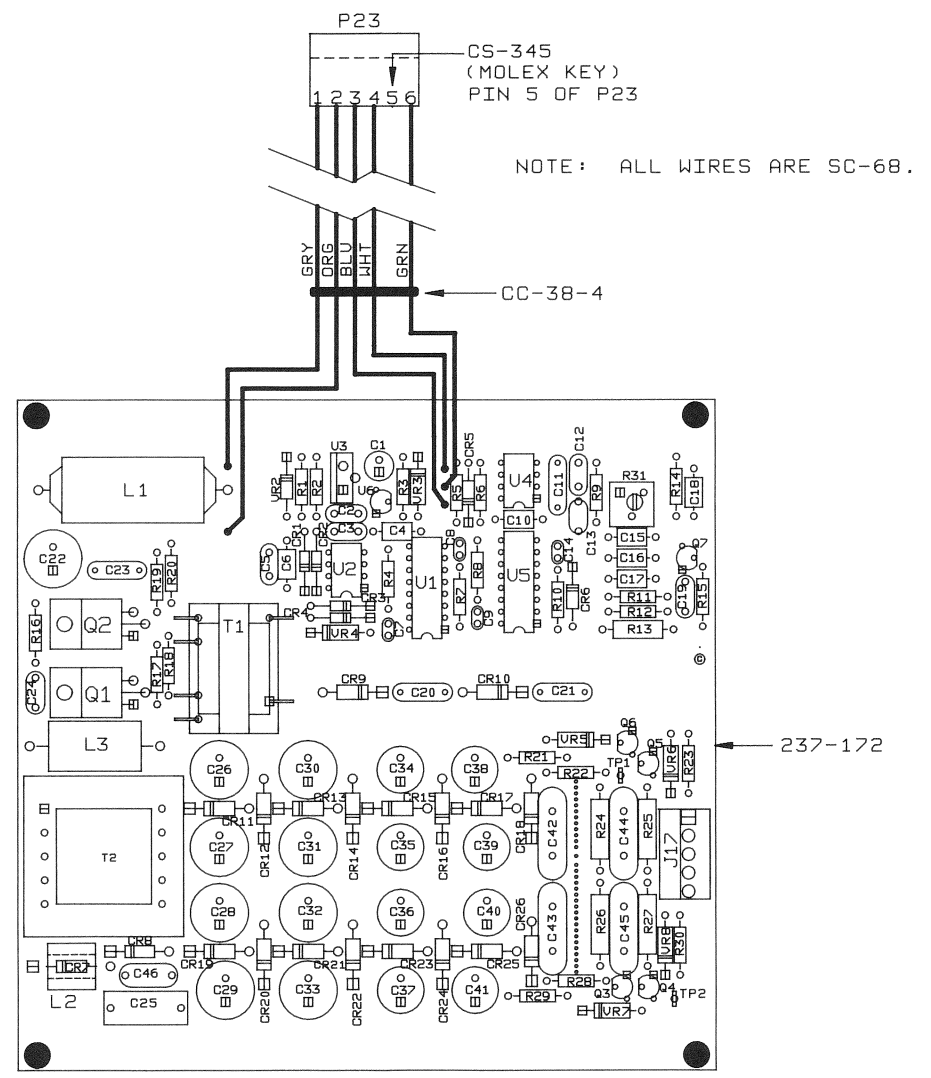

NOTE:
COMPONENT LEADS MUST MAINTAIN A .080 MAX. ICICLE.

NOTE:
FOR COMPONENT INFORMATION
REFER TO BILL OF MATERIAL
237-000-05.

MODEL	NEXT ASSEMBLY	QTY.
237		
USED ON		

DO NOT SCALE THIS DRAWING		DIMENSIONAL TOLERANCES UNLESS OTHERWISE SPECIFIED		DATE 6/20/88	SCALE 1:1	TITLE COMPONENT LAYOUT	
KEITHLEY KEITHLEY INSTRUMENTS INC. CLEVELAND, OHIO 44139		XX=±.015	ANG.=±1°	DRN. KEK	ENG. APPR. JGB	RESONANT CONVERTER BOARD	
		XXX=±.005	FRAC.=±1/64	MATERIAL		C	NO. 237-170
		SURFACE MAX. 53		FINISH			